

## Screw jacks with travelling ball nut (Mod.B)

### 3.1 MA Series Mod.B - STRUCTURAL ELEMENTS

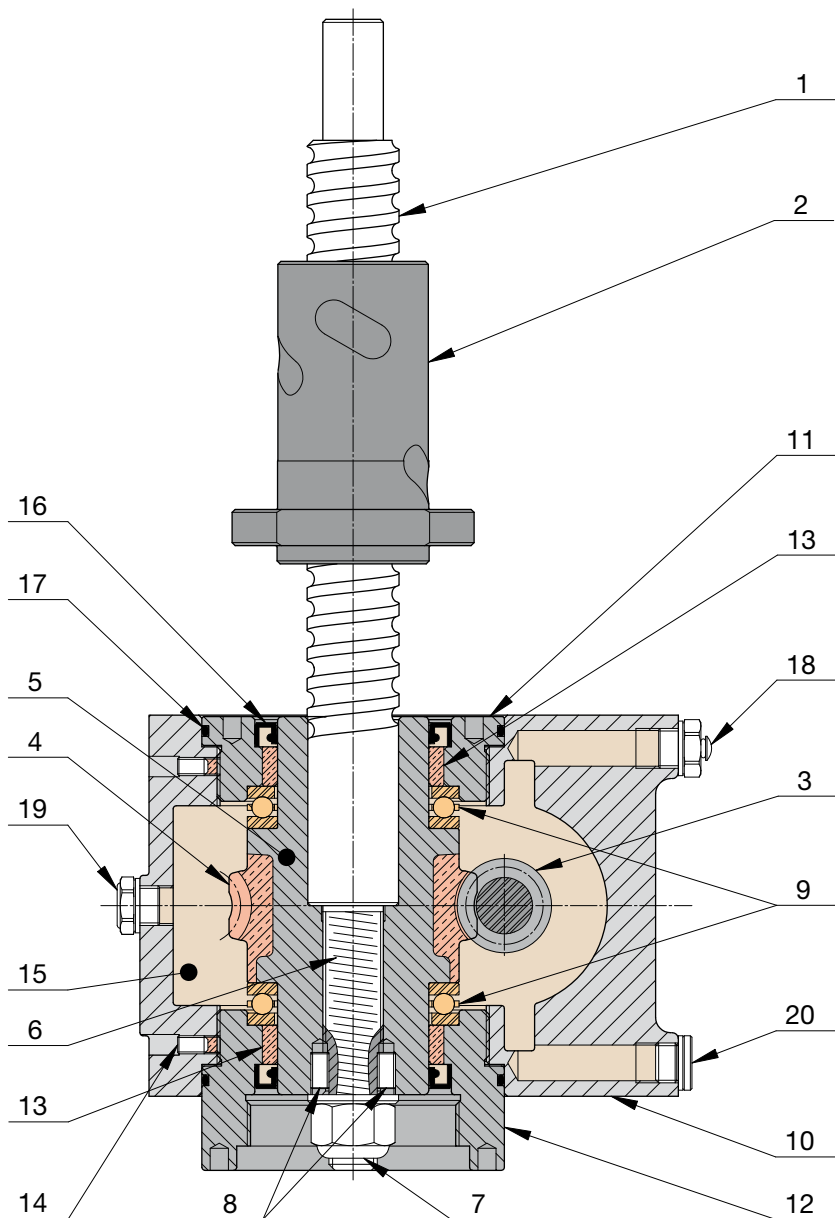

- |  |   |
|--|---|
| 1 - ball screw in quenched and tempered alloy steel  | 11 - low cover  |
| 2 - ball nut in case-hardened steel with flange according to DIN 69051 (available also with cylindrical flange), with grease nipple and end seals  | 12 - raised cover; may also be used as a centring diameter                    |
| 3 - worm with ground ZI involute thread profile (UNI 4760) in case-hardened steel  | 13 - wormwheel radial bronze guide for higher stiffness and better efficiency |
| 4 - bronze worm wheel with true involute profile ZI (UNI 4760)   | 14 - grub screw to prevent the threaded cover unscrewing                      |
| 5 - cast iron support of the bronze worm wheel rim (size 5 and 10: entire wormwheel in bronze)   | 15 - long-life synthetic oil lubricated worm gearbox                          |
| 6 - ball screw fixed to the worm wheel through the cylindrical centring part and metric thread LEFT-HAND for PUSH load or RIGHT-HAND for PULL load | 16 - radial lubricant seal  |
| 7 - lock nut with opposite metric thread direction to ensure a safe ball screw fixing  | 17 - O-ring   |
| 8 - ball screw – wormwheel pins against unscrewing   | 18 - breather   |
| 9 - thrust ball bearing for high load capacity   | 19 - oil level plug   |
| 10- gear box   | 20 - oil drain plug   |

# Screw jacks with travelling ball nut (Mod.B)

## 3.2 SJ Series Mod.B - STRUCTURAL ELEMENTS

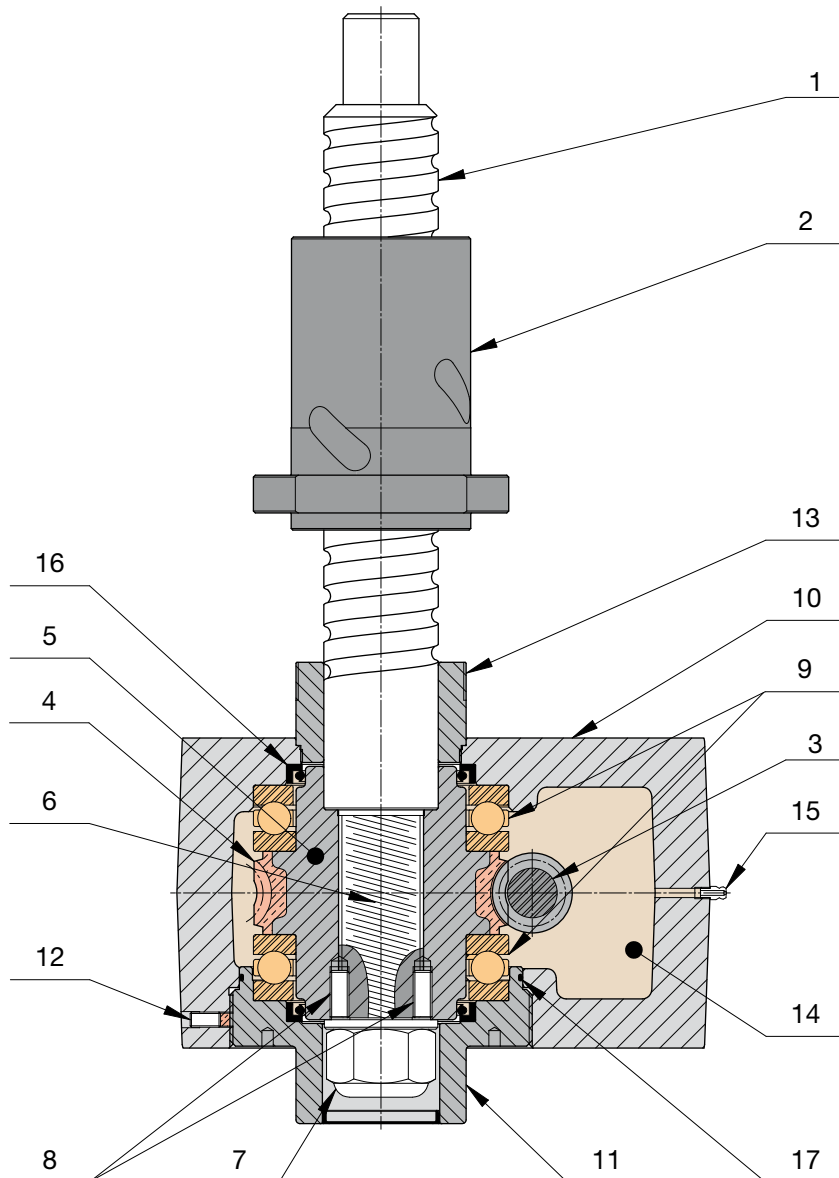

3

- |  |  |
|--|--|
| 1 - ball screw in quenched and tempered alloy steel  | 10 - gear box  |
| 2 - ball nut in case-hardened steel with flange according to DIN 69051 (available also with cylindrical flange), with grease nipple and end seals  | 11 - threaded cover; may also be used as a centring diameter     |
| 3 - worm with ground ZI involute thread profile (UNI 4760) in case-hardened steel  | 12 - grub screw to prevent the threaded cover unscrewing         |
| 4 - bronze worm wheel with true involute profile ZI (UNI 4760)   | 13 - guide bush for ball screw, may be used as a spigot diameter |
| 5 - cast iron support of the bronze worm wheel rim (size 5 ... 100: entire wormwheel in bronze)  | 14 - long-life synthetic grease lubricated worm gearbox          |
| 6 - ball screw fixed to the worm wheel through the cylindrical centring part and metric thread LEFT-HAND for PUSH load or RIGHT-HAND for PULL load | 15 - grease nipple   |
| 7 - lock nut with opposite metric thread direction to ensure a safe ball screw fixing  | 16 - radial lubricant seal                                       |
| 8 - ball screw – wormwheel pins against unscrewing   | 17 - O-ring  |
| 9 - thrust ball bearing for high load capacity   |  |

## Screw jacks with travelling ball nut (Mod.B)

### 3.3 HS Series - STRUCTURAL ELEMENTS

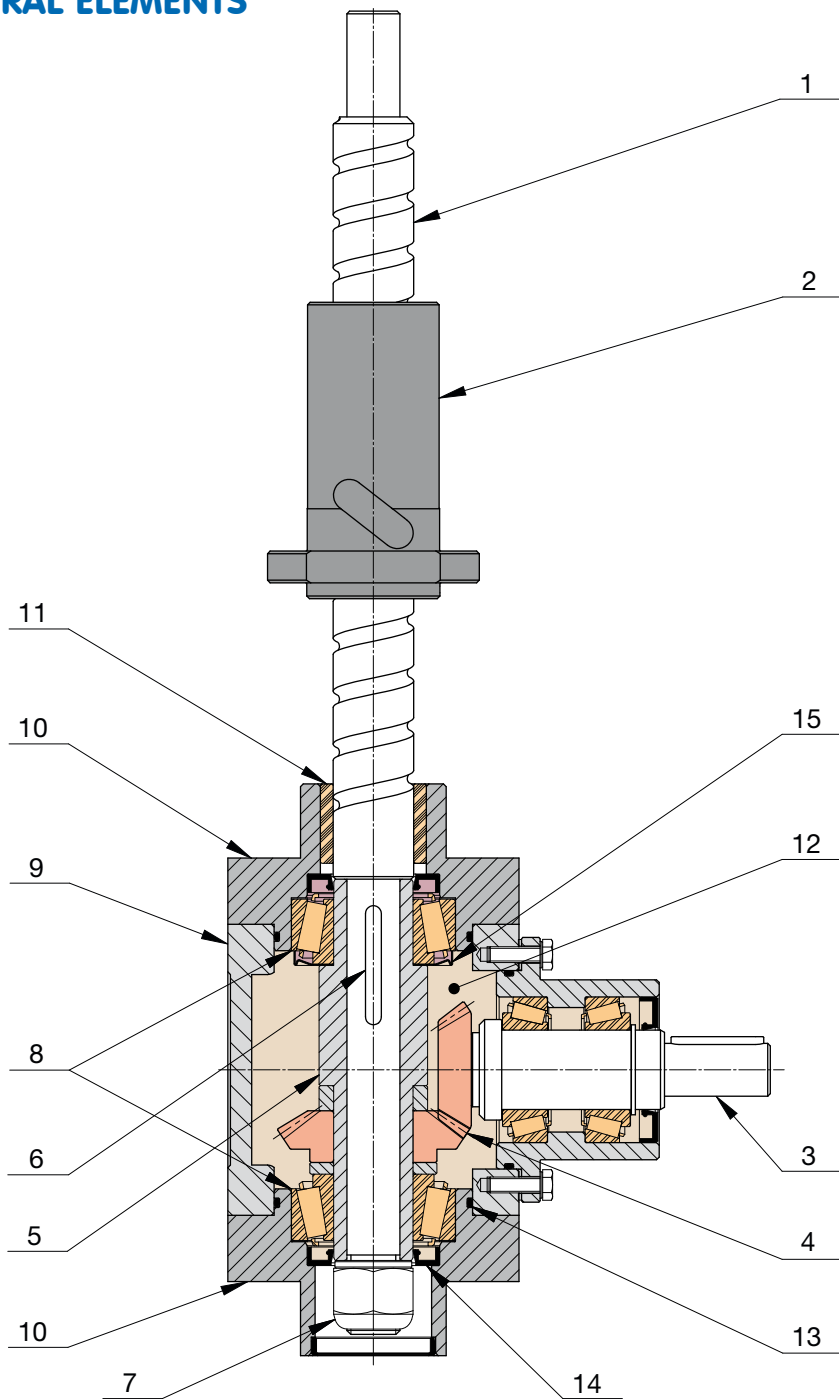

- |   |  |
|---|--|
| 1 - ball screw in quenched and tempered alloy steel   | 9 - gear box   |
| 2 - ball nut in case-hardened steel with flange according to DIN 69051 (available also with cylindrical flange), with grease nipple and end seals | 10- square covers with centring diameter for screw jack positioning  |
| 3 - solid input shaft with key (or flange and hollow shaft for motor coupling)  | 11 - plastic guide bush  |
| 4 - bevel gear in case-hardened and tempered steel  | 12 - long-life synthetic oil lubricated worm gearbox and bearings  |
| 5 - output hollow shaft in hardened and tempered steel  | 13 - O-ring  |
| 6 - key to transmit the torque to the output shaft  | 14 - radial lubricant seal   |
| 7 - key to transmit the torque to the output shaft  | 15 - NILOS seal which allows to create a chamber for the lubricant of the upper bearing; used only in case of vertical mounting position |
| 8 - thrust ball bearing for high load capacity  |  |



## Screw jacks with travelling ball nut (Mod.B)

### 3.6 TECHNICAL DATA

MA BS Series Mod.B		MA 5 BS	MA 10 BS	MA 25 BS	MA 50 BS
Load capacity [kN], (push - pull)		5	10	25	50
Worm gear centre distance [mm]		30	40	50	63
Ratio	fast RV	1 : 4 (4 : 16)	1 : 5 (4 : 20)	1 : 6 (4 : 24)	1 : 7 (4 : 28)
	normal RN	1 : 16 (2 : 32)	1 : 20	1 : 18 (2 : 36)	1 : 14 (2 : 28)
	slow RL	1 : 24	1 : 25	1 : 24	1 : 28
Gear box material		casting in aluminium alloy EN 1706 - AC-ALSi10Mg T6		casting in spheroidal graphite iron EN-GJS-500-7 (UNI EN 1563)	
Mass of gear box without ball screw [kg]		2.2	4.3	13	26

SJ BS Series Mod.B		SJ 5 BS	SJ 10 BS	SJ 25 BS	SJ 50 BS	SJ 100 BS
Load capacity [kN], (push - pull)		5	10	25	50	100
Worm gear centre distance [mm]		25	30	50	63	63
Ratio	high RH	1 : 4 (5 : 20)	-	-	-	-
	fast RV	1 : 6.25 (4 : 25)	1 : 4 (4 : 16)	1 : 6 (4 : 24)	1 : 7 (4 : 28)	1 : 7 (4 : 28)
	normal RN	1 : 12.5 (2 : 25)	1 : 16 (2 : 32)	1 : 18 (2 : 36)	1 : 14 (2 : 28)	1 : 14 (2 : 28)
	slow RL	1 : 25	1 : 24	1 : 24	1 : 28	1 : 28
Gear box material		casting in aluminium alloy EN 1706 - AC-ALSi10Mg T6		casting in grey cast iron EN-GJL-250 (UNI EN 1561)		
Mass of gear box without ball screw [kg]		1.5	2.3	10.4	25	35

Serie HS		HS 10	HS 25	HS 50
Load capacity [kN], (push - pull)		10	25	50
Housing side dimensions [mm]		86	110	134
Ratio	R1	1 : 1	1 : 1	1 : 1
	R1.5	1 : 1.5	1 : 1.5	1 : 1.5
	R2	1 : 2	1 : 2	1 : 2
	R3	1 : 3	1 : 3	1 : 3
	R4	1 : 4	1 : 4	1 : 4
Gear box material		casting in grey cast iron EN-GJL-250 (UNI EN 1561)		
Mass of gear box without ball screw [kg]		5.9	11.3	20

## Screw jacks with travelling ball nut (Mod.B)

### 3.6 TECHNICAL DATA

MA 80 BS	MA 150 BS	MA 200 BS	MA 350 BS	<b>MA BS Series Mod.B</b>	
80	150	200	350	Load capacity [kN], (push - pull)	
63	80	100	125	Worm gear centre distance [mm]	
1 : 7 (4 : 28)	1 : 8 (4 : 32)	1 : 8 (4 : 32)	3 : 32	RV fast	Ratio
1 : 14 (2 : 28)	1 : 24	1 : 24	1 : 16 (2 : 32)	RN normal	
1 : 28	1 : 32	1 : 32	1 : 32	RL slow	
casting in spheroidal graphite iron EN-GJS-500-7 (UNI EN 1563)				Gear box material	
26	48	75	145	Mass of gear box without ball screw [kg]	

SJ 150 BS	SJ 200 BS	SJ 250 BS	SJ 300 BS	SJ 400 BS	<b>SJ BS Series Mod.B</b>	
150	200	250	300	400	Load capacity [kN], (push - pull)	
80	90	90	110	140	Worm gear centre distance [mm]	
-	-	-	-	-	RH high	
1 : 8 (4 : 32)	1 : 7 (4 : 28)	1 : 7 (4 : 28)	3 : 29	3 : 28	RV fast	Ratio
1 : 24	-	-	-	-	RN normal	
1 : 32	1 : 28	1 : 28	1 : 30	1 : 29	RL slow	
casting in grey cast iron EN-GJL-250 (UNI EN 1561)				welded steel S355 J2 (UNI EN 10025)	Gear box material	
55	75	75	120	260	Mass of gear box without ball screw [kg]	

HS 100	HS 150	HS 200	<b>Serie HS</b>		
80	150	200	Load capacity [kN], (push - pull)		
166	200	250	Housing side dimensions [mm]		
1 : 1	1 : 1	1 : 1	R1		
1 : 1.5	1 : 1.5	1 : 1.5	R1.5		
1 : 2	1 : 2	1 : 2	R2		
1 : 3	1 : 3	1 : 3	R3		
1 : 4	1 : 4	1 : 4	R4		
casting in grey cast iron EN-GJL-250 (UNI EN 1561)			Gear box material		
38	67	120	Mass of gear box without ball screw [kg]		

## Screw jacks with travelling ball nut (Mod.B)

### 3.7 Ball screws and nuts technical data

Ball screws produced with whirling process, accuracy grade IT 5 <sup>(1)</sup>

Ball screw BS $d_o \times P_h$	Ball nut code <sup>(2)</sup>	Ball $D_w [mm]$	n° of starts $N_p$	n° of circuits $i$	Dynamic load $C_a [kN]$	Static load $C_{0a} [kN]$
BS 16 × 5	SFN-_.16.05.3R	3.175	1	3	9	13.5
BS 16 × 10	SFN-_.16.10.3R	3.175	1	3	9.1	13.7
BS 20 × 5	SFN-_.20.05.3R	3.175	1	3	10.4	18.4
	SFN-_.20.05.5R	3.175	1	5	15.7	28.5
BS 20 × 10	SFN-_.20.10.3R	3.175	1	3	10.5	18.3
BS 25 × 5	SFN-_.25.05.3R	3.175	1	3	12	24.4
BS 25 × 10	SFN-_.25.10.3R	3.969	1	3	15.6	28.6
BS 32 × 5	SFN-_.32.05.4R	3.175	1	4	17.6	43.9
BS 32 × 10	SFN-_.32.10.3R	6.35	1	3	28.3	49.6
	SFN-_.32.10.4R	6.35	1	4	36.3	63
	SFN-_.32.10.5R	6.35	1	5	44	77
BS 32 × 20	SFN-_.32.20.3R	6.35	1	3	27.9	45.6
BS 40 × 10	SFN-_.40.10.5R	6.35	1	5	52	107
BS 40 × 20	SFN-_.40.20.3R	6.35	1	3	33.4	64
BS 50 × 10	SFN-_.50.10.5R	7.144	1	5	72	163
BS 50 × 20	SFN-_.50.20.4R	7.144	1	4	56	121
BS 63 × 10	SFN-_.63.10.5R	7.144	1	5	80	209
BS 63 × 20	SFN-_.63.20.4R	9.525	1	4	88	191
BS 80 × 10	SFN-_.80.10.6R	7.144	1	6	112	370
BS 80 × 16	SFN-_.80.16.5R	9.525	1	5	129	341
BS 80 × 20	SFN-_.80.20.5R-F	9.525	1	5	145	419
BS 80 × 20	SFN-_.80.20.4R	12.7	1	4	185	462
BS 100 × 16	SFN-_.100.16.5R	9.525	1	5	147	454
BS 100 × 20	SFN-_.100.20.5R	12.7	1	5	251	732
BS 120 × 20	SFN-_.120.20.7R	15.875	1	7	500	1578

<sup>(1)</sup> - ball screws with accuracy grade IT 3 can be supplied on request

<sup>(2)</sup> - the nut code in the table is incomplete; to complete it refer to Ch. 3.8 "Ball nuts dimensions"

## Screw jacks with travelling ball nut (Mod.B)

### 3.7 Ball screws and nuts technical data

#### Rolled ball screws, accuracy grade IT 7

Ball screw $BS\ d_0 \times P_h$	Ball nut code <sup>(2)</sup>	Ball $D_w [mm]$	n° of starts $N_p$	n° of circuits $i$	Dynamic load $C_a [kN]$	Static load $C_{0a} [kN]$
BS 16 × 5	SFN-_.16.05.3R	3.175	1	3	8.1	12.2
BS 16 × 10	SFN-_.16.10.3R	3.175	1	3	8.1	12.3
BS 16 × 16	SFN-_.16.16.2R-2	3.175	2	2	10.0	14.5
BS 20 × 5	SFN-_.20.05.3R	3.175	1	3	9.1	16.5
	SFN-_.20.05.5R	3.175	1	5	14.1	25.6
BS 20 × 10	SFN-_.20.10.3R	3.175	1	3	9.5	16.5
BS 20 × 20	SFN-_.20.20.2R-2	3.175	2	2	12.1	20.9
BS 25 × 5	SFN-_.25.05.3R	3.175	1	3	10.8	22
BS 25 × 10	SFN-_.25.10.3R	3.969	1	3	14	25.7
BS 25 × 25	SFN-_.25.25.2R-2	3.175	2	2	13.6	27.3
BS 32 × 5	SFN-_.32.05.4R	3.175	1	4	15.8	39.5
BS 32 × 10	SFN-_.32.10.3R	6.35	1	3	25.5	44.6
	SFN-_.32.10.4R	6.35	1	4	32.7	57
	SFN-_.32.10.5R	6.35	1	5	39.7	69
BS 32 × 20	SFN-_.32.20.3R	6.35	1	3	25.1	41
BS 32 × 32	SFN-_.32.32.2R-2	6.35	2	2	35.0	58
BS 40 × 10	SFN-_.40.10.5R	6.35	1	5	47.1	96
BS 40 × 20	SFN-_.40.20.3R	6.35	1	3	30	56
BS 40 × 40	SFN-_.40.40.2R-2	6.35	2	2	40.3	77

<sup>(2)</sup> - the nut code in the table is incomplete; to complete it refer to Ch. 3.8 "Ball nuts dimensions"



# Screw jacks with travelling ball nut (Mod.B)

## 3.8 Ball nut dimensions

### Nuts with flange according to DIN 69051

Ball screw BS $d_0 \times P_h$	Nut code	Flange type	Dimensions [mm]										
			$D_1$	$D_4$	$D_5$	$D_6$	$D_7$	$L_1$	$L_3$	$L_7$	$L_8$	$L_{10}$	$L$
BS 16 × 5	SFN-D.16.05.3R	1	28	38	5.5	48	M6	10	5	10	40	8	48
BS 16 × 10	SFN-D.16.10.3R	1	28	38	5.5	48	M6	10	5	10	40	8	66
BS 16 × 16	SFN-D.16.16.2R-2	1	28	38	5.5	48	M6	10	5	10	40	8	53
BS 20 × 5	SFN-D.20.05.3R	1	36	47	6.6	58	M6	10	5	10	44	8	48
	SFN-D.20.05.5R	1	36	47	6.6	58	M6	10	5	10	44	8	63
BS 20 × 10	SFN-D.20.10.3R	1	36	47	6.6	58	M6	10	5	10	44	8	66
BS 20 × 20	SFN-D.20.20.2R-2	1	36	47	6.6	58	M6	10	5	10	44	8	70
BS 25 × 5	SFN-D.25.05.3R	1	40	51	6.6	62	M6	10	6	10	48	8	48
BS 25 × 10	SFN-D.25.10.3R	1	40	51	6.6	62	M6	10	6	10	48	8	69
BS 25 × 25	SFN-D.25.25.2R-2	1	40	51	6.6	62	M6	10	6	10	48	8	69
BS 32 × 5	SFN-D.32.05.4R	1	50	65	9	80	M6	16	6	12	62	8	57
BS 32 × 10	SFN-D.32.10.3R	1	50	65	9	80	M6	16	6	12	62	8	79
	SFN-D.32.10.4R	1	50	65	9	80	M6	16	6	12	62	8	89
	SFN-D.32.10.5R	1	50	65	9	80	M6	16	6	12	62	8	100
BS 32 × 20	SFN-D.32.20.3R	1	56	71	9	86	M6	16	6	14	65	8	88
BS 32 × 32	SFN-D.32.32.2R-2	1	56	71	9	86	M6	20	6	14	65	8	91
BS 40 × 10	SFN-D.40.10.5R	2	63	78	9	93	M8×1	16	7	14	70	10	103
BS 40 × 20	SFN-D.40.20.3R	2	63	78	9	93	M8×1	16	7	14	70	10	115
BS 40 × 40	SFN-D.40.40.2R-2	2	63	78	9	93	M8×1	16	7	14	70	10	107
BS 50 × 10	SFN-D.50.10.5R	2	75	93	11	110	M8×1	16	7	16	85	10	106
BS 50 × 20	SFN-D.50.20.4R	2	75	93	11	110	M8×1	16	7	16	85	10	142
BS 63 × 10	SFN-D.63.10.5R	2	90	108	11	125	M8×1	16	7	18	95	10	108
BS 63 × 20	SFN-D.63.20.4R	2	95	115	13.5	135	M8×1	25	9	20	100	10	155
BS 80 × 10	SFN-D.80.10.6R	2	105	125	13.5	145	M8×1	16	9	20	110	10	121
BS 80 × 16	SFN-D.80.16.5R	2	125	145	13.5	165	M8×1	25	9	25	130	10	157
BS 80 × 20	SFN-D.80.20.5R-F	2	125	145	13.5	165	M8×1	25	9	25	130	10	142
BS 80 × 20	SFN-D.80.20.4R	2	125	145	13.5	165	M8×1	25	9	25	130	10	161
BS 100 × 16	SFN-D.100.16.5R	2	150	176	17.5	202	M8×1	25	9	30	155	10	165
BS 100 × 20	SFN-D.100.20.5R	2	150	176	17.5	202	M8×1	25	9	30	155	10	190
BS 120 × 20	SFN-D.120.20.7R	2	170	196	17.5	222	M8×1	30	12	30	175	10	240

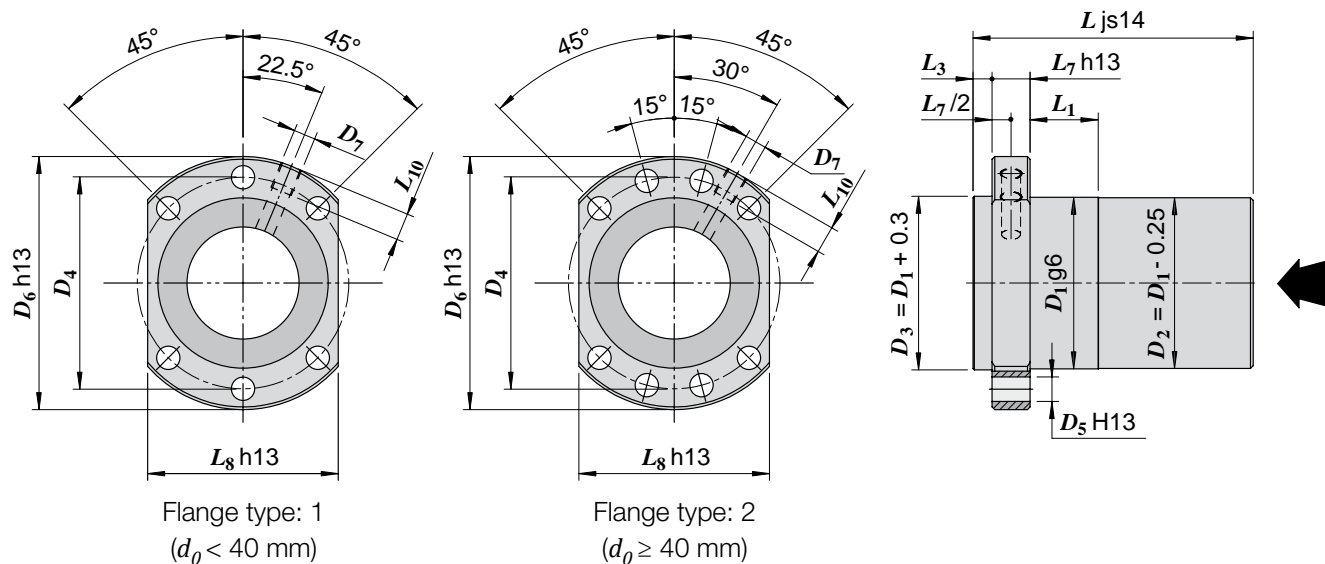

## Screw jacks with travelling ball nut (Mod.B)

### 3.8 Ball nut dimensions

#### Nuts with flange at SERVOMECH drawing SERVOMECH

Ball screw BS $d_0 \times P_h$	Nut code	Flange type	Dimensions [mm]									
			$D_1$	$D_4$	$D_5$	$D_6$	$D_7$	$L_1$	$L_3$	$L_7$	$L_{10}$	$L$
BS 16 × 5	SFN-S.16.05.3R	1	28	38	5.5	48	M6	10	5	10	8	48
BS 16 × 10	SFN-S.16.10.3R	1	28	38	5.5	48	M6	10	5	10	8	66
BS 16 × 16	SFN-S.16.16.2R-2	1	30	38	5.5	48	M6	10	5	10	8	53
BS 20 × 5	SFN-S.20.05.3R	1	36	47	6.6	58	M6	10	5	10	8	48
	SFN-S.20.05.5R	1	36	47	6.6	58	M6	10	5	10	8	63
BS 20 × 10	SFN-S.20.10.3R	1	36	47	6.6	58	M6	10	5	10	8	66
BS 20 × 20	SFN-S.20.20.2R-2	1	36	47	6.6	58	M6	10	5	10	8	70
BS 25 × 5	SFN-S.25.05.3R	1	40	51	6.6	62	M6	10	6	10	8	48
BS 25 × 10	SFN-S.25.10.3R	1	40	51	6.6	62	M6	10	6	10	8	69
BS 25 × 25	SFN-S.25.25.2R-2	1	40	51	6.6	62	M6	10	6	10	8	69
BS 32 × 5	SFN-S.32.05.4R	1	50	65	9	80	M6	16	6	12	8	57
BS 32 × 10	SFN-S.32.10.3R	1	50	65	9	80	M6	16	6	12	8	79
	SFN-S.32.10.4R	1	50	65	9	80	M6	16	6	12	8	89
	SFN-S.32.10.5R	1	50	65	9	80	M6	16	6	12	8	100
BS 32 × 20	SFN-S.32.20.3R	1	56	71	9	86	M6	16	6	14	8	88
BS 32 × 32	SFN-S.32.32.2R-2	1	56	71	9	86	M6	20	6	14	8	91
BS 40 × 10	SFN-S.40.10.5R	2	63	78	9	93	M8×1	16	7	14	10	103
BS 40 × 20	SFN-S.40.20.3R	2	63	78	9	93	M8×1	16	7	14	10	115
BS 40 × 40	SFN-S.40.40.2R-2	2	68	78	9	93	M8×1	16	7	14	10	107
BS 50 × 10	SFN-S.50.10.5R	2	75	93	11	110	M8×1	16	7	16	10	106
BS 50 × 20	SFN-S.50.20.4R	2	75	93	11	110	M8×1	16	7	16	10	142
BS 63 × 10	SFN-S.63.10.5R	2	90	108	11	125	M8×1	16	7	18	10	108
BS 63 × 20	SFN-S.63.20.4R	2	95	115	13.5	135	M8×1	25	9	20	10	155
BS 80 × 10	SFN-S.80.10.6R	2	105	125	13.5	145	M8×1	16	9	20	10	121
BS 80 × 16	SFN-S.80.16.5R	2	125	145	13.5	165	M8×1	25	9	25	10	157
BS 80 × 20	SFN-S.80.20.5R-F	2	125	145	13.5	165	M8×1	25	9	25	10	142
BS 80 × 20	SFN-S.80.20.4R	2	125	145	13.5	165	M8×1	25	9	25	10	161
BS 100 × 16	SFN-S.100.16.5R	2	150	176	17.5	202	M8×1	25	9	30	10	165
BS 100 × 20	SFN-S.100.20.5R	2	150	176	17.5	202	M8×1	25	9	30	10	190
BS 120 × 20	SFN-S.120.20.7R	2	170	196	17.5	222	M8×1	30	12	30	10	240

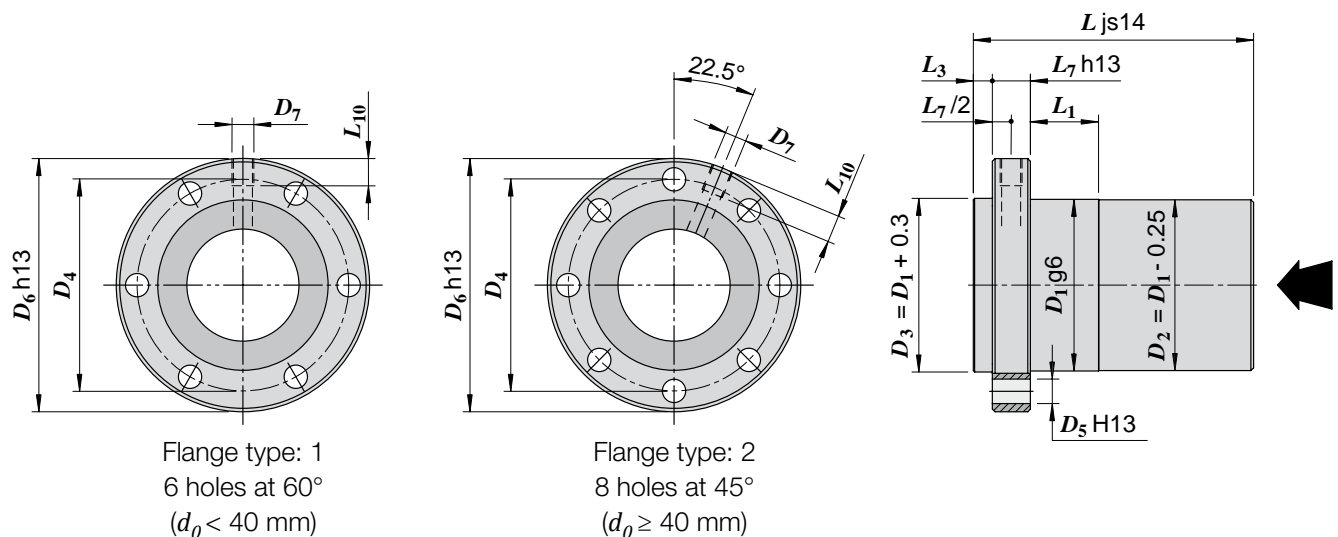

## Screw jacks with travelling ball nut (Mod.B)

### 3.9 Ball nut life

#### Ball screw diameter 16 - 20, accuracy grade IT 3 or IT 5

Following life diagrams refer to a constant applied load, without shocks and 90 % ball screw reliability. For different load and/or reliability conditions, please refer to ch. 1.11 "Ball screw life calculation" on page 18 or contact SERVOMECH.

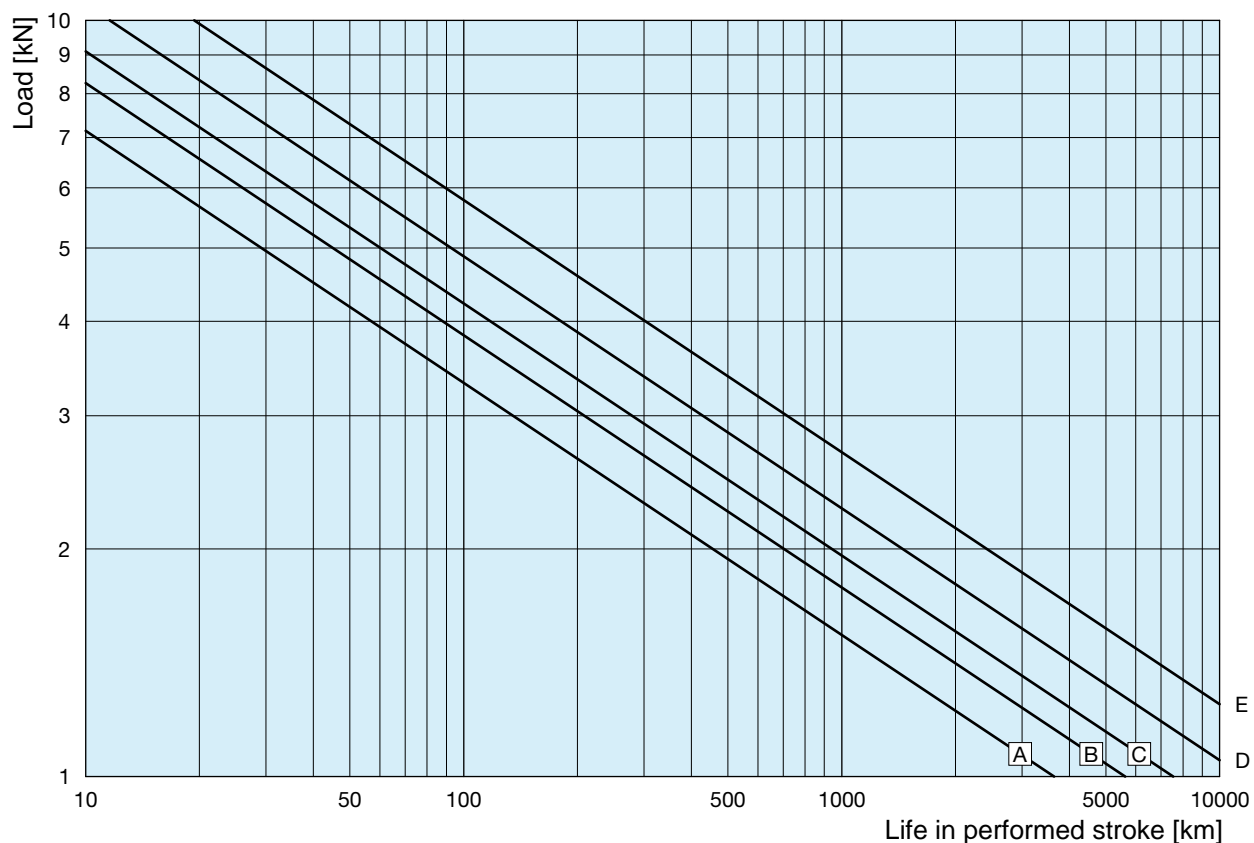

BALL SCREW	Ball [mm]	N° of starts	N° of circuits	$C_a$ [kN]	$C_{0a}$ [kN]	CURVE
BS 16x5	3.175	1	3	9	13.5	A
BS 16x10	3.175	1	3	9.1	13.7	C
BS 20x5	3.175	1	3	10.4	18.4	B
BS 20x5	3.175	1	5	15.7	28.5	E
BS 20x10	3.175	1	3	10.5	18.3	D

## Screw jacks with travelling ball nut (Mod.B)

### 3.9 Ball nut life

#### Ball screw diameter 16 - 20, accuracy grade IT 7

Following life diagrams refer to a constant applied load, without shocks and 90 % ball screw reliability. For different load and/or reliability conditions, please refer to ch. 1.11 "Ball screw life calculation" on page 18 or contact SERVOMECH.

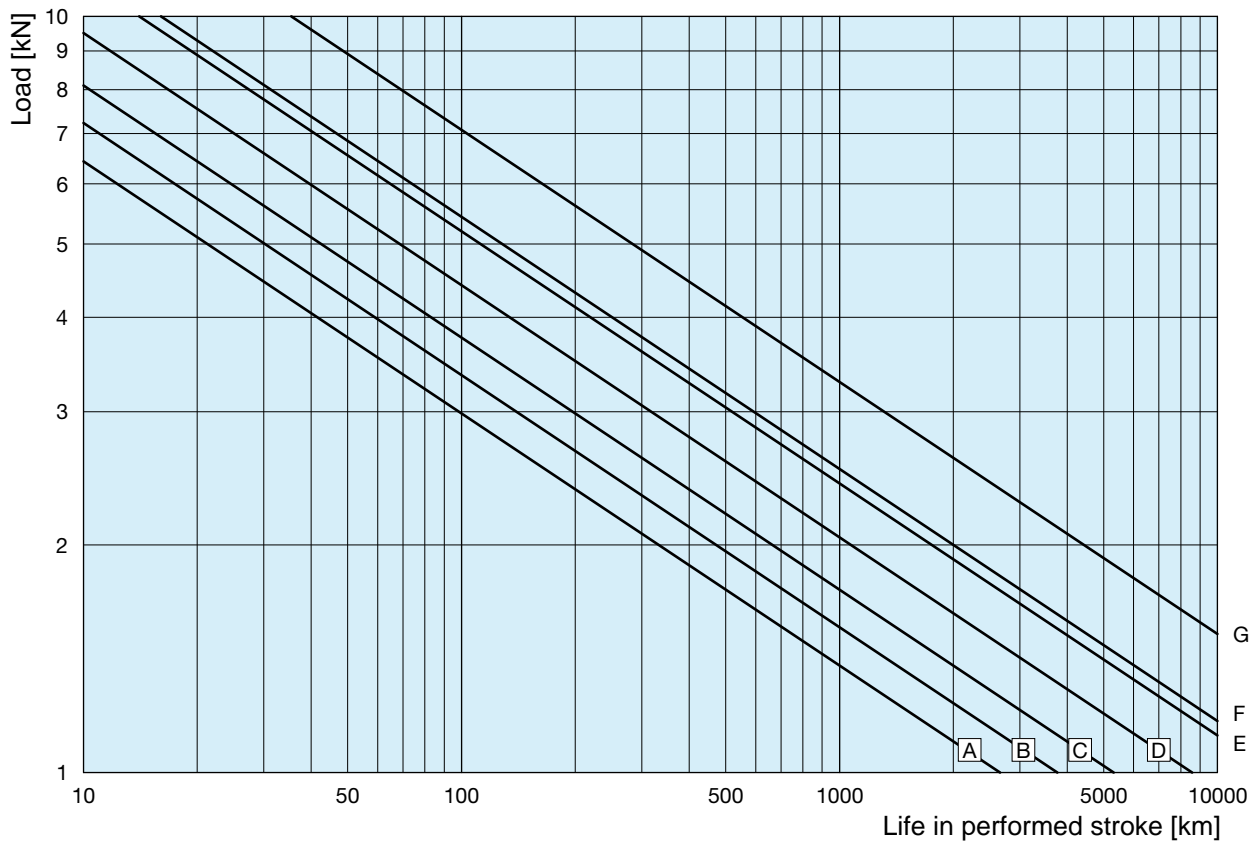

BALL SCREW	Ball [mm]	N° of starts	N° of circuits	$C_a$ [kN]	$C_{0a}$ [kN]	CURVE
BS 16×5	3.175	1	3	8.1	12.2	A
BS 16×10	3.175	1	3	8.1	12.3	C
BS 16×16	3.175	2	2	10	14.5	F
BS 20×5	3.175	1	3	9.1	16.5	B
BS 20×5	3.175	1	5	14.1	25.6	E
BS 20×10	3.175	1	3	9.5	16.5	D
BS 20×20	3.175	2	2	12.1	20.9	G

## Screw jacks with travelling ball nut (Mod.B)

### 3.9 Ball nut life

#### Ball screw diameter 25 - 32, accuracy grade IT 3 or IT 5

Following life diagrams refer to a constant applied load, without shocks and 90 % ball screw reliability. For different load and/or reliability conditions, please refer to ch. 1.11 "Ball screw life calculation" on page 18 or contact SERVOMECH.

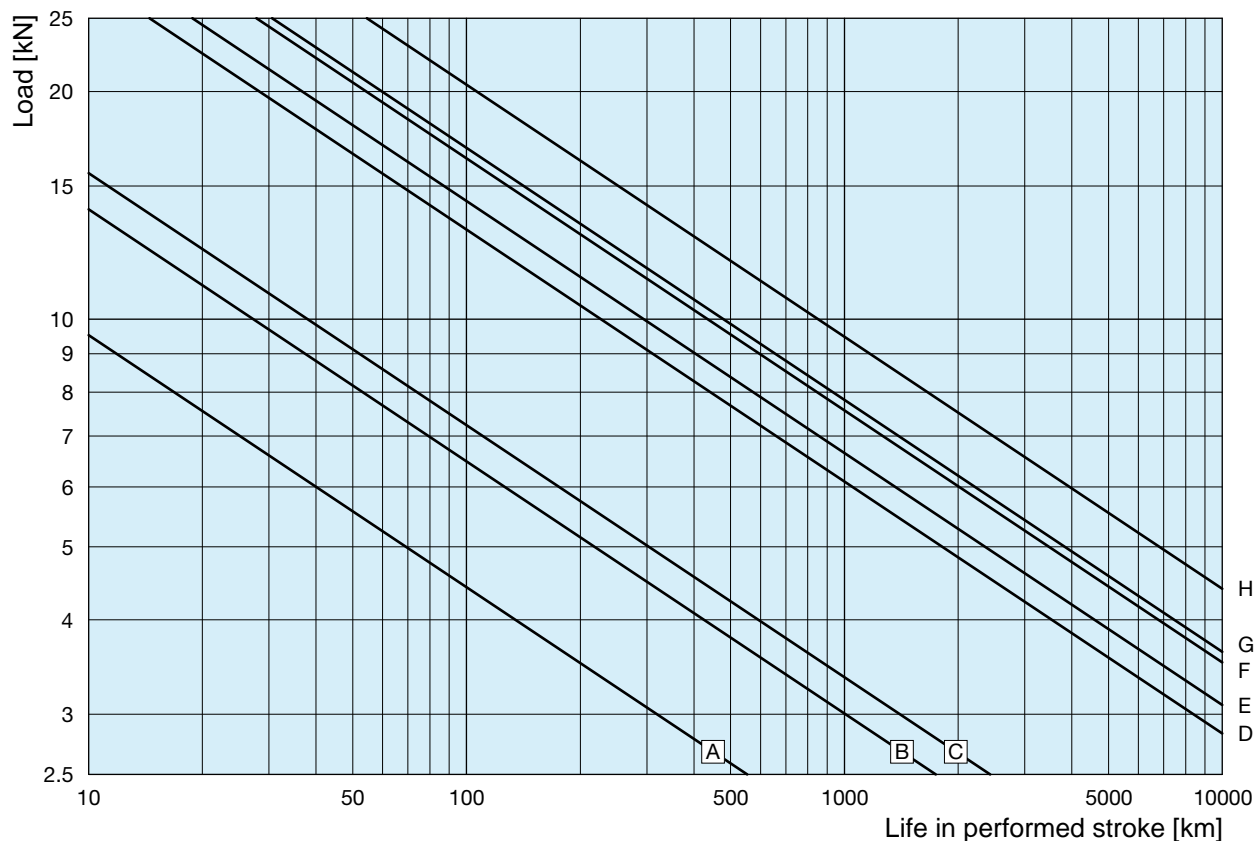

BALL SCREW	Ball [mm]	N° of starts	N° of circuits	$C_a$ [kN]	$C_{0a}$ [kN]	CURVE
BS 25x5	3.175	1	3	12	24.4	A
BS 25x10	3.969	1	3	15.6	28.6	C
BS 32x5	3.175	1	4	17.6	43.9	B
BS 32x10	6.35	1	3	28.3	49.6	D
BS 32x10	6.35	1	4	36.3	63	G
BS 32x10	6.35	1	5	44	77	H
BS 32x20	6.35	1	3	27.9	45.6	F
BS 32x32	6.35	1	2	21.2	34.9	E

## Screw jacks with travelling ball nut (Mod.B)

### 3.9 Ball nut life

#### Ball screw diameter 25 - 32, accuracy grade IT 7

Following life diagrams refer to a constant applied load, without shocks and 90 % ball screw reliability. For different load and/or reliability conditions, please refer to ch. 1.11 "Ball screw life calculation" on page 18 or contact SERVOMECH.

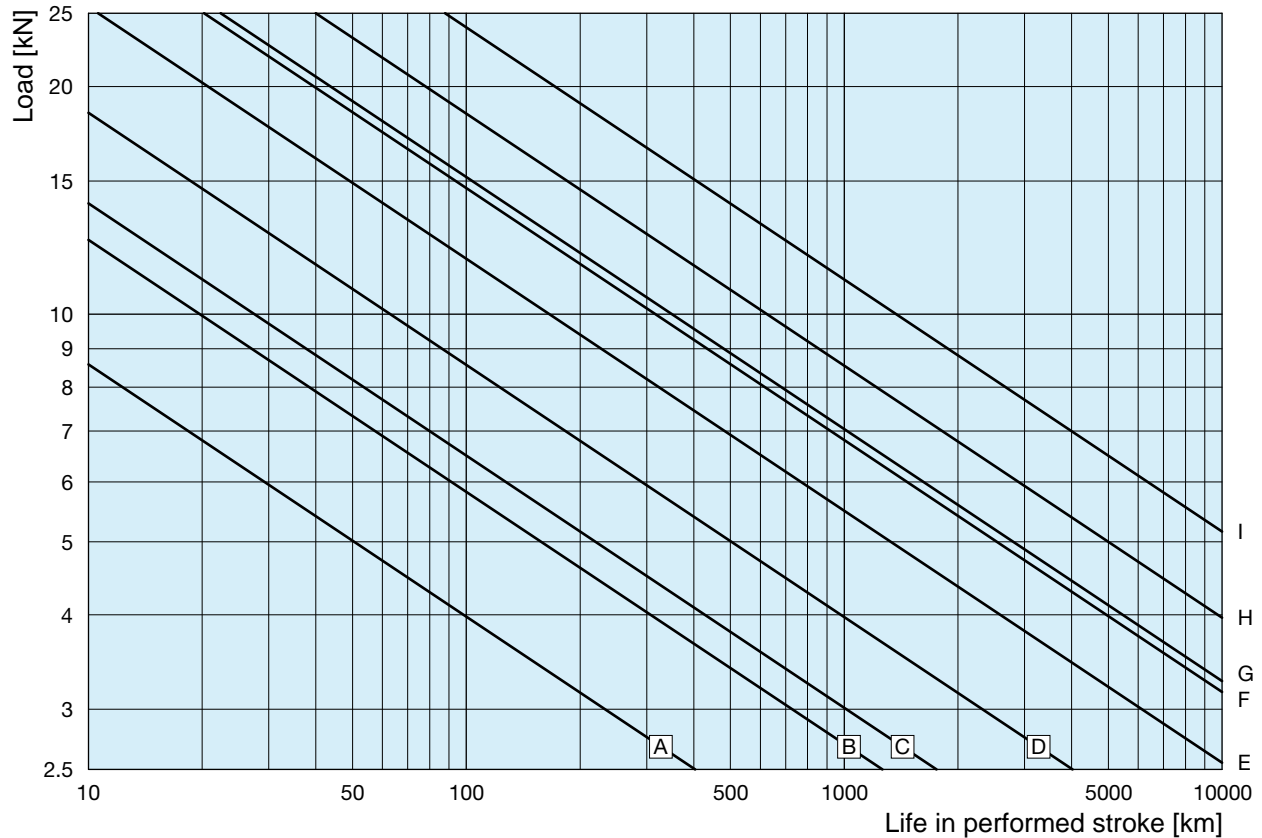

BALL SCREW	Ball [mm]	N° of starts	N° of circuits	$C_a$ [kN]	$C_{0a}$ [kN]	CURVE
BS 25x5	3.175	1	3	10.8	22	A
BS 25x10	3.969	1	3	14	25.7	C
BS 25x25	3.175	2	2	13.6	27.3	D
BS 32x5	3.175	1	4	15.8	39.5	B
BS 32x10	6.35	1	3	25.5	44.6	E
BS 32x10	6.35	1	4	32.7	57	G
BS 32x10	6.35	1	5	39.7	69	H
BS 32x20	6.35	1	3	25.1	41	F
BS 32x32	6.35	2	2	35	58	I

## Screw jacks with travelling ball nut (Mod.B)

### 3.9 Ball nut life

#### Ball screw diameter 40, accuracy grade IT 3 or IT 5, IT 7

Following life diagrams refer to a constant applied load, without shocks and 90 % ball screw reliability. For different load and/or reliability conditions, please refer to ch. 1.11 "Ball screw life calculation" on page 18 or contact SERVOMECH.

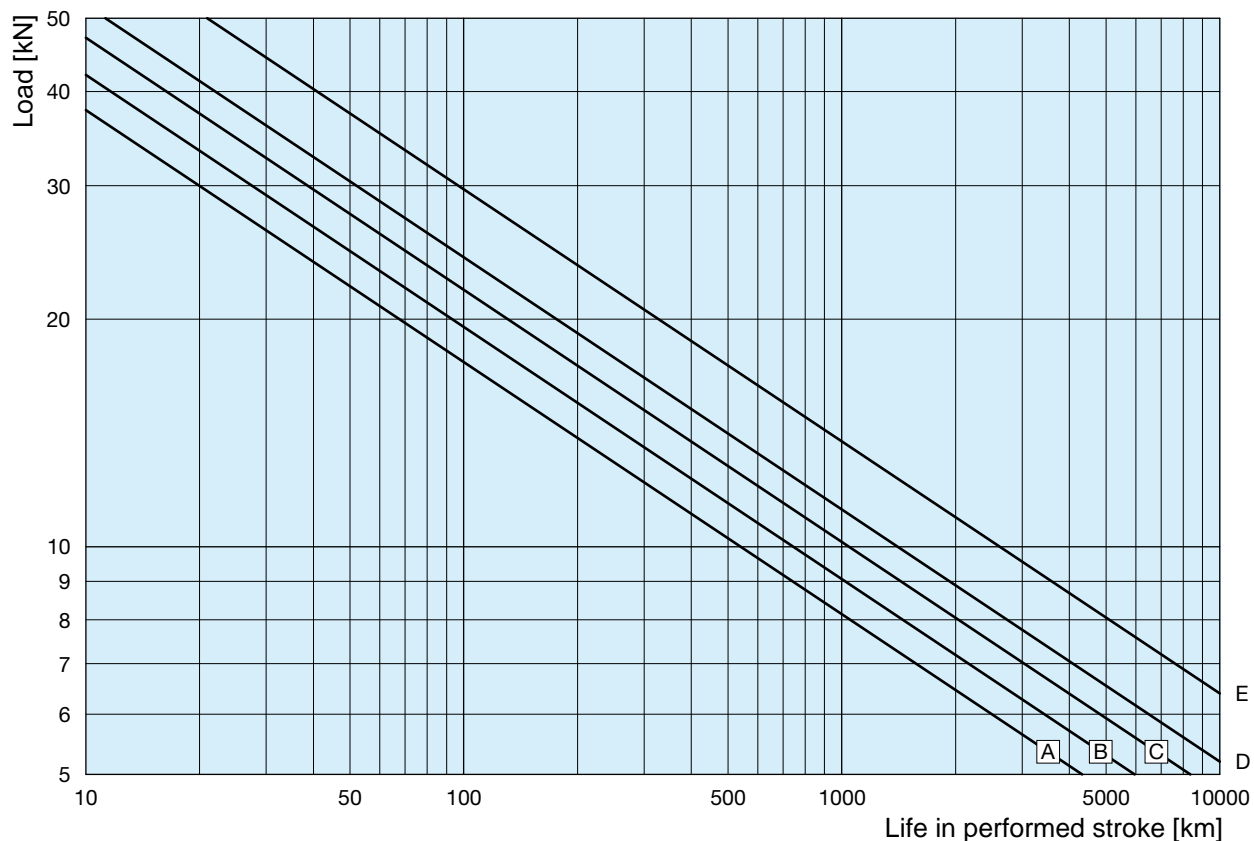

BALL SCREW	Ball [mm]	Accuracy grade	N° of starts	N° of circuits	$C_a$ [kN]	$C_{0a}$ [kN]	CURVE
BS 40x10	6.35	IT 3 or IT 5	1	5	52	107	D
		IT 7	1	5	47.1	96	C
BS 40x20	6.35	IT 3 or IT 5	1	3	33.4	64	B
		IT 7	1	3	30	56	A
BS 40x40	6.35	IT 7	2	2	40.3	77	E

## Screw jacks with travelling ball nut (Mod.B)

### 3.9 Ball nut life

#### Ball screw diameter 50 - 63, accuracy grade IT 3 or IT 5

Following life diagrams refer to a constant applied load, without shocks and 90 % ball screw reliability. For different load and/or reliability conditions, please refer to ch. 1.11 "Ball screw life calculation" on page 18 or contact SERVOMECH.

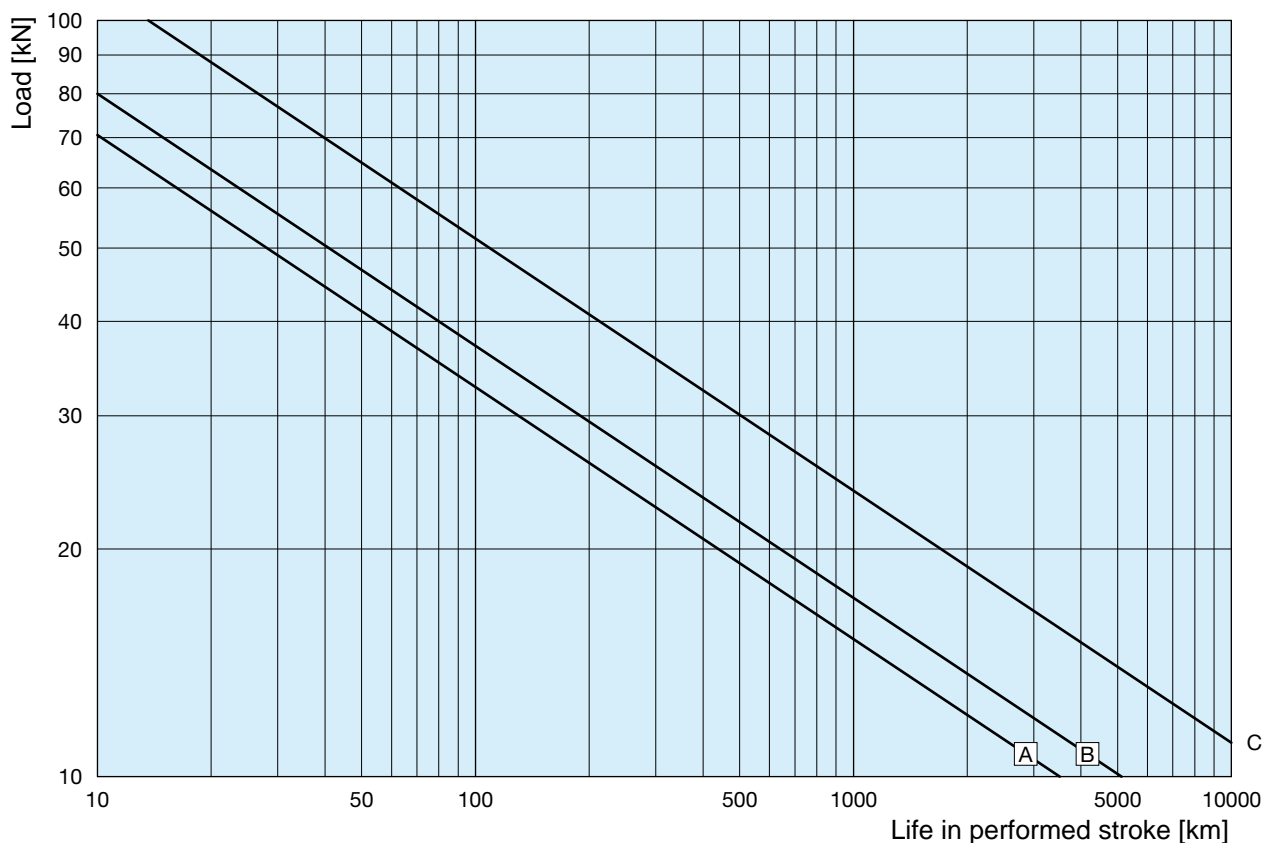

BALL SCREW	Ball [mm]	N° of starts	N° of circuits	$C_a$ [kN]	$C_{0a}$ [kN]	CURVE
BS 50×10	7.144	1	5	72	163	A
BS 50×20	7.144	1	4	56	121	A
BS 63×10	7.144	1	5	80	209	B
BS 63×20	9.525	1	4	88	191	C



## Screw jacks with travelling ball nut (Mod.B)

### 3.9 Ball nut life

#### Ball screw diameter 80, accuracy grade IT 3 or IT 5

Following life diagrams refer to a constant applied load, without shocks and 90 % ball screw reliability. For different load and/or reliability conditions, please refer to ch. 1.11 "Ball screw life calculation" on page 18 or contact SERVOMECH.

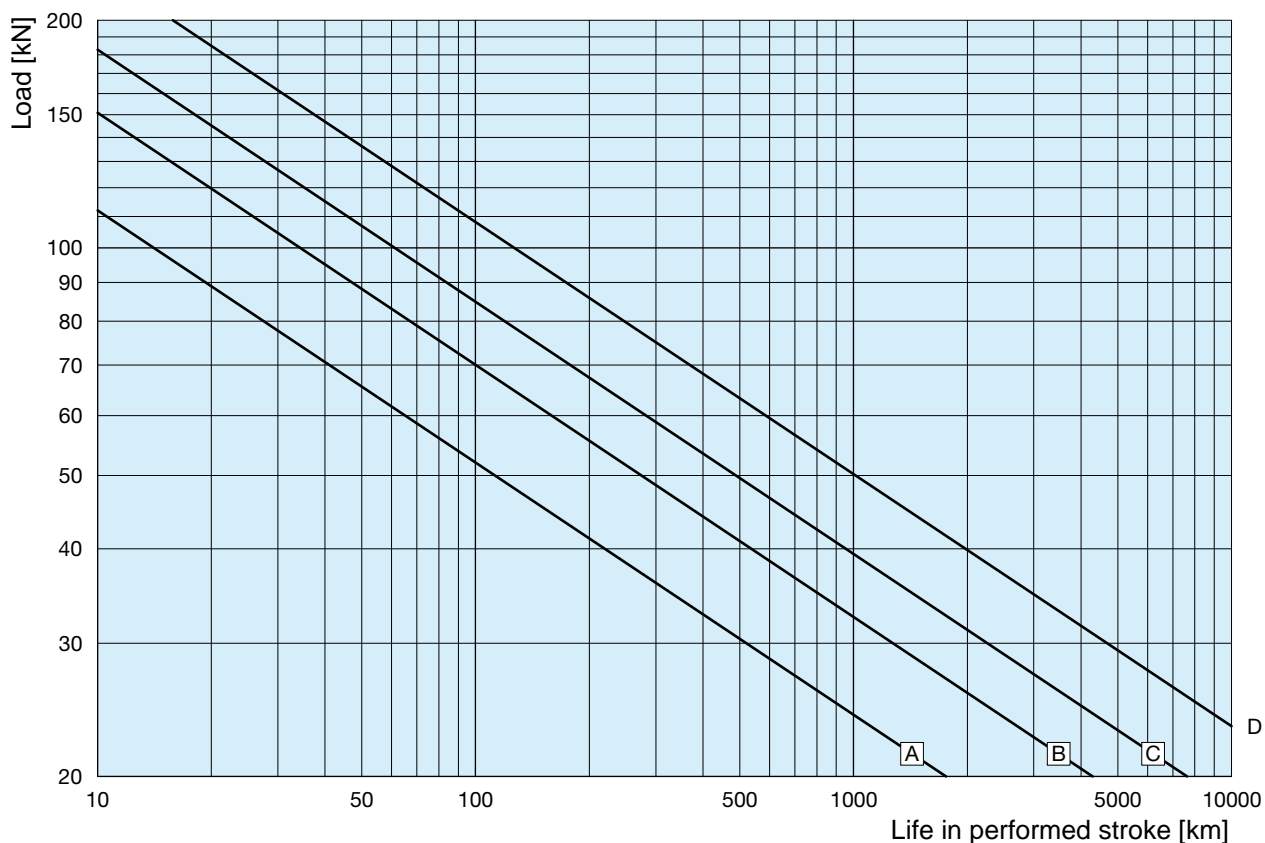

BALL SCREW	Ball [mm]	N° of starts	N° of circuits	$C_a$ [kN]	$C_{0a}$ [kN]	CURVE
BS 80×10	7.144	1	6	112	370	A
BS 80×16	9.525	1	5	129	341	B
BS 80×20	9.525	1	5	145	419	C
BS 80×20	12.7	1	4	185	462	D

## Screw jacks with travelling ball nut (Mod.B)

### 3.9 Ball nut life

#### Ball screw diameter 100 - 120, accuracy grade IT 3 or IT 5

Following life diagrams refer to a constant applied load, without shocks and 90 % ball screw reliability. For different load and/or reliability conditions, please refer to ch. 1.11 "Ball screw life calculation" on page 18 or contact SERVOMECH.

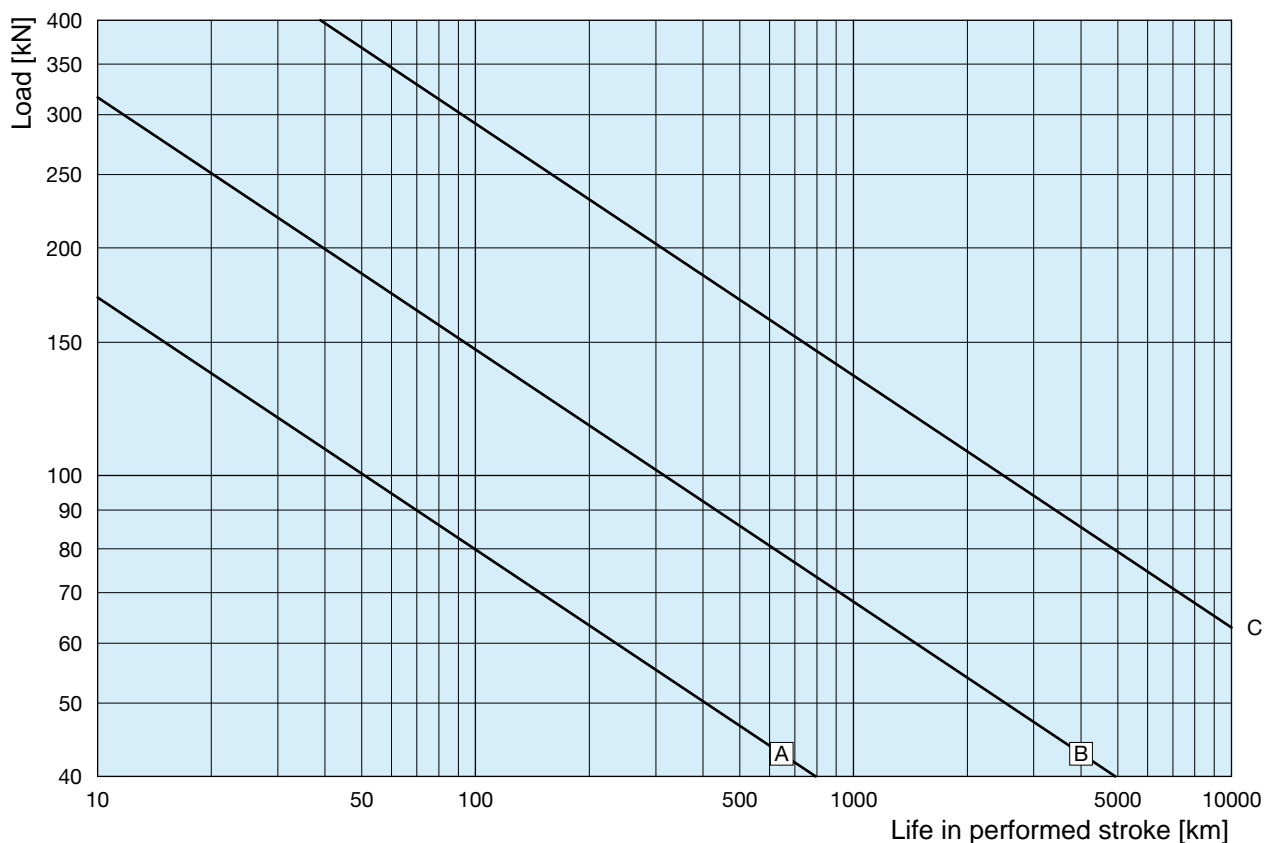

BALL SCREW	Ball [mm]	N° of starts	N° of circuits	$C_a$ [kN]	$C_{0a}$ [kN]	CURVE
BS 100×16	9.525	1	5	147	454	A
BS 100×20	12.7	1	5	251	732	B
BS 120×20	15.875	1	7	500	1578	C

## Screw jacks with travelling ball nut (Mod.B)

### 3.10 Ball screw direct efficiency

Thanks to balls interposed between the threaded shaft and nut, the friction coefficient between balls and tracks is constant also in case of speed and load variations. This implies that also the ball screw efficiency can be considered as constant by varying working conditions and it is called theoretical ball screw efficiency.

The theoretical efficiency of the ball screw depends on the geometry of the ball tracks only. **For a conservative calculation, it is recommended to apply a safety factor of 0.92 on the given efficiency in order to consider also the dependence on load and speed.**

The following tables show the theoretical efficiency of all ball screws available for screw jacks Mod.B with rotating screw and travelling nut.

$d_0$	16		20			25				32				40			50		63		80			100		120
$P_h$	5	10	5	10	20	5	6	10	25	5	10	20	32	10	20	40	10	20	10	20	10	16	20	16	20	20
$\eta_{BS}$	0.94	0.97	0.93	0.96	0.98	0.91	0.93	0.95	0.98	0.89	0.94	0.97	0.98	0.93	0.96	0.98	0.91	0.95	0.89	0.94	0.87	0.91	0.93	0.89	0.91	0.90

### 3.11 Worm gear direct efficiency

$\eta_{RID}$	MA 5			MA 10			MA 25			MA 50 MA 80			MA 150			MA 200			MA 350					
	RATIO			RATIO			RATIO			RATIO			RATIO			RATIO			RATIO					
$n_1$ [rpm]	RV	RN	RL	RV	RN	RL	RV	RN	RL	RV	RN	RL	RV	RN	RL	RV	RN	RL	RV	RN	RL	RV	RN	RL
3 000	0.84	0.75	0.68	0.84	0.73	0.71	0.84	0.77	0.72	0.85	0.80	0.72	0.85	0.76	0.73	0.85	0.77	0.74	0.84	0.82	0.76	0.84	0.82	0.76
1 500	0.81	0.71	0.62	0.82	0.68	0.66	0.82	0.73	0.68	0.83	0.77	0.68	0.83	0.73	0.68	0.84	0.74	0.71	0.83	0.80	0.72	0.83	0.80	0.72
1 000	0.80	0.68	0.60	0.81	0.65	0.63	0.81	0.71	0.65	0.81	0.75	0.64	0.81	0.69	0.65	0.82	0.71	0.68	0.82	0.78	0.70	0.82	0.78	0.70
750	0.79	0.67	0.58	0.80	0.64	0.61	0.80	0.69	0.63	0.81	0.73	0.62	0.80	0.68	0.64	0.81	0.69	0.65	0.80	0.77	0.68	0.80	0.77	0.68
500	0.78	0.65	0.56	0.78	0.61	0.59	0.78	0.66	0.60	0.79	0.72	0.60	0.79	0.66	0.61	0.80	0.66	0.63	0.78	0.75	0.65	0.78	0.75	0.65
300	0.77	0.63	0.53	0.77	0.58	0.56	0.77	0.64	0.57	0.77	0.69	0.57	0.77	0.62	0.57	0.78	0.63	0.59	0.77	0.73	0.62	0.77	0.73	0.62
100	0.73	0.59	0.48	0.74	0.52	0.50	0.73	0.59	0.52	0.74	0.64	0.51	0.74	0.57	0.51	0.75	0.58	0.53	0.75	0.68	0.55	0.75	0.68	0.55
START.	0.68	0.53	0.41	0.68	0.46	0.44	0.68	0.52	0.44	0.68	0.57	0.48	0.67	0.47	0.42	0.68	0.47	0.43	0.65	0.59	0.44	0.65	0.59	0.44

$\eta_{RID}$	SJ 5				SJ 10			SJ 25			SJ 50 SJ 100			SJ 150			SJ 200 SJ 250		SJ 300		SJ 400	
	RATIO				RATIO			RATIO			RATIO			RATIO			RATIO		RATIO		RATIO	
$n_1$ [rpm]	RH	RV	RN	RL	RV	RN	RL	RV	RN	RL	RV	RN	RL	RV	RN	RL	RV	RL	RV	RL	RV	RL
1 500	0.71	0.71	0.65	0.56	0.72	0.63	0.55	0.73	0.65	0.60	0.74	0.69	0.61	0.74	0.65	0.61	0.74	0.63	0.73	0.63	0.73	0.63
1 000	0.70	0.70	0.63	0.53	0.71	0.61	0.54	0.72	0.63	0.58	0.72	0.66	0.57	0.72	0.62	0.58	0.73	0.60	0.72	0.60	0.72	0.61
750	0.70	0.69	0.62	0.52	0.70	0.59	0.51	0.71	0.61	0.56	0.72	0.65	0.55	0.71	0.60	0.57	0.72	0.58	0.71	0.58	0.72	0.59
500	0.68	0.67	0.61	0.50	0.70	0.58	0.50	0.70	0.59	0.53	0.70	0.64	0.54	0.70	0.58	0.54	0.71	0.56	0.70	0.56	0.70	0.56
300	0.67	0.66	0.59	0.48	0.68	0.56	0.47	0.68	0.57	0.51	0.69	0.62	0.50	0.69	0.55	0.50	0.70	0.51	0.68	0.53	0.68	0.53
100	0.64	0.64	0.56	0.44	0.65	0.52	0.42	0.65	0.52	0.46	0.66	0.57	0.46	0.66	0.50	0.46	0.66	0.47	0.64	0.47	0.64	0.47
START.	0.59	0.60	0.52	0.39	0.60	0.47	0.37	0.60	0.46	0.39	0.61	0.50	0.42	0.59	0.42	0.38	0.60	0.38	0.56	0.37	0.55	0.35

$\eta_{RID}$	Serie HS (all sizes, all ratios)
RUNNING	0.90
STARTING	0.93

## Screw jacks with travelling ball nut (Mod.B)

### 3.12 Static braking torque

The braking torque is the necessary torque to keep the load on the screw jack in a static position. The braking torque shall be applied with a brake on the screw jack input shaft.

#### Braking torque calculation

The braking torque value is calculated as follows:

$$T_f = \frac{1.2 \cdot F \cdot P_h \cdot \eta'_{BS} \cdot \eta'_{RID}}{2\pi \cdot u}$$

where:

- $\eta'_{BS}$  - ball screw back-driving efficiency
- $\eta'_{RID}$  - worm gear back-driving efficiency
- $F$  [kN] - load applied on the screw jack
- $P_h$  [mm] - ball screw thread helix lead
- $u$  - worm gear ratio ( $u > 1$ )

The calculated  $T_f$  value must be compared with the minimum braking torque threshold value, which must always be assured. The real braking torque value is therefore the highest one of the two values.

$$T_{F\text{eff}} = \max(T_f; T_{F\text{min}})$$

Following tables show the  $T_{F\text{min}}$  and the back-driving efficiency values.

NOTE: where no value is stated, it means that the system is ideally self-locking. Actually, due to hardly predictable external factors, such as vibrations and shocks, it still can be possible to have a not self-locking system and therefore, even in this case, it is necessary to apply a braking torque to sustain the load in position, equal to the minimum  $T_{F\text{min}}$ .

$d_0$	16		20			25				32				40			50		63		80			100		120
$P_h$	5	10	5	10	20	5	6	10	25	5	10	20	32	10	20	40	10	20	10	20	10	16	20	16	20	20
$\eta'_{BS}$	0.94	0.97	0.92	0.96	0.98	0.90	0.92	0.95	0.98	0.88	0.94	0.97	0.98	0.92	0.96	0.98	0.90	0.95	0.88	0.94	0.85	0.90	0.92	0.88	0.90	0.88

$\eta'_{RID}$	MA 5			MA 10			MA 25			MA 50 MA 80			MA 150			MA 200			MA 350		
	RATIO			RATIO			RATIO			RATIO			RATIO			RATIO					
	RV	RN	RL	RV	RN	RL	RV	RN	RL	RV	RN	RL	RV	RN	RL	RV	RN	RL	RV	RN	RL
	0.68	0.26	-	0.69	-	-	0.68	0.21	-	0.68	0.38	-	0.66	-	-	0.66	0.02	-	0.60	0.42	-

$\eta'_{RID}$	SJ 5				SJ 10			SJ 25			SJ 50 SJ 100			SJ 150			SJ 200 SJ 250		SJ 300		SJ 400	
	RATIO				RATIO			RATIO			RATIO			RATIO		RATIO		RATIO				
	RH	RV	RN	RL	RV	RN	RL	RV	RN	RL	RV	RN	RL	RV	RN	RL	RV	RL	RV	RL	RV	RL
	0.66	0.68	0.42	-	0.68	0.26	-	0.68	0.21	-	0.68	0.38	-	0.66	-	-	0.66	-	0.57	-	0.53	-

$\eta'_{RID}$	Serie HS (all sizes, all ratios)
	0.90

$T_{F\text{min}}$	MA 5	MA 10	MA 25	MA 50 MA 80	MA 150	MA 200	MA 350
[Nm]	0.2	0.35	1.5	2.4	5.3	6.8	13.4

$T_{F\text{min}}$	SJ 5	SJ 10	SJ 25	SJ 50 SJ 100	SJ 150	SJ 200 SJ 250	SJ 300	SJ 400
[Nm]	0.2	0.35	1.5	2.4	5.3	6.8	11.5	14.4

$T_{F\text{min}}$	HS 10	HS 25	HS 50	HS 100	HS 150	HS 200
[Nm]	0.45	2	3.2	5.5	7.2	9.3

**Screw jacks with travelling ball nut (Mod.B)**

**3.13 Overall dimensions**

**MA BS Series Mod.B**

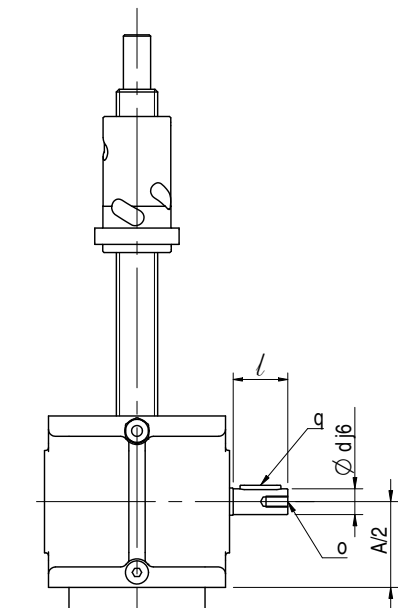
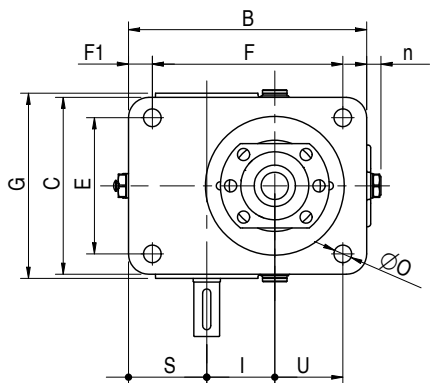
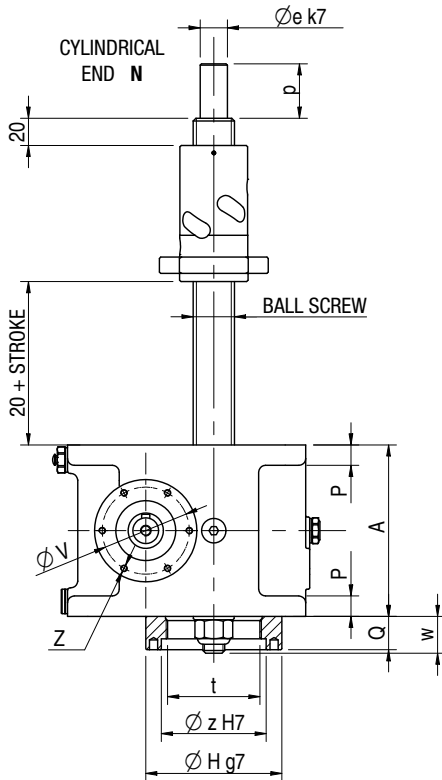

**Vers.1: single input shaft**

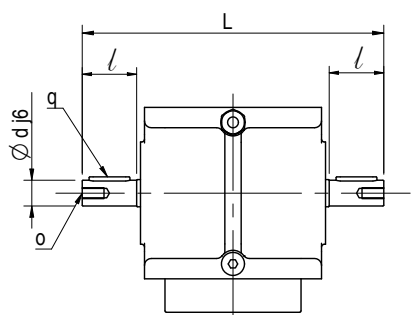

**Vers.2: double input shaft**

**Vers.3: flange and hollow shaft IEC**

**Vers.4: flange and hollow shaft IEC + 2<sup>nd</sup> shaft**

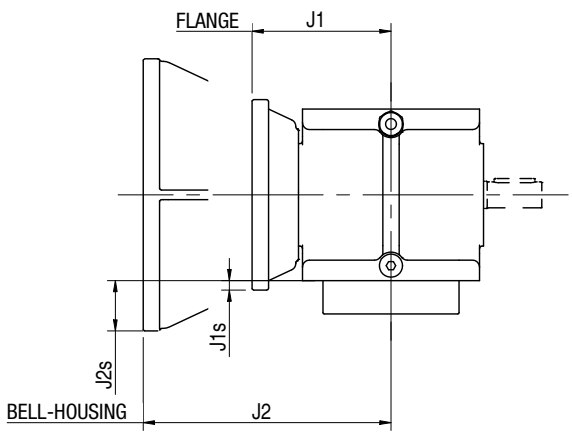

**Vers.5: Vers.1 with bell-housing and coupling IEC**

**Vers.6: Vers.2 with bell-housing and coupling IEC**

3

## Screw jacks with travelling ball nut (Mod.B)

### 3.13 Overall dimensions

#### MA BS Series Mod.B

SIZE	MA 5 BS	MA 10 BS	MA 25 BS	MA 50 BS	MA 80 BS	MA 150 BS	MA 200 BS	MA 350 BS
BALL SCREW	BS 16-20 x P <sub>h</sub>	BS 25 x P <sub>h</sub>	BS 32 x P <sub>h</sub>	BS 40 x P <sub>h</sub>	BS 50 x P <sub>h</sub>	BS 63 x P <sub>h</sub>	BS 80 x P <sub>h</sub>	BS 100 x P <sub>h</sub>
A	80	100	126	160	160	200	230	280
B	124	140	175	235	235	276	330	415
C	80	105	130	160	160	200	230	300
E	62	80	100	120	120	150	175	230
F	95	110	140	190	190	220	270	330
F1	12.5	14	17.5	23	23	26	30	42
G	100	114	136	165	165	205	256	326
∅ H	65	80	100	120	120	160	190	240
I	30	40	50	63	63	80	100	125
L	149	179	221.5	269	269	330	378	490
∅ O	9	9	13	17	17	21	28	34
Q	15	16	24	26	26	30	35	40
S	46.5	46	57.5	80	80	91	113	121
U	31	38	50	70	70	75	87	126
∅ V	42	46	64	63	63	74	110	118
Z	M5, depth 10	M5, depth 12	M5, depth 10	M6, depth 14	M6, depth 14	M6, depth 14	M10, depth 20	M10, depth 25
∅ d	10	14	19	24	24	28	32	38
∅ e	12	15	20	30	40	40	50	70
l	22	30	40	50	50	60	60	80
n	—	—	10	10	10	12	10	10
o	M5, depth 10	M6, depth 14	M8, depth 16	M8, depth 16	M8, depth 16	M8, depth 16	M10, depth 24	M12, depth 32
p	19	24	40	40	45	50	60	65
q	3x3x15	5x5x20	6x6x30	8x7x40	8x7x40	8x7x40	10x8x40	10x8x60
t	M45x1.5	M55x1.5	M70x2	M90x2	M90x2	M110x2	M150x3	M180x3
w	15	17	25	36	38	41	42	45
∅ z	50	60	77	95	95	120	160	200
J1	63 B5/B14: 62	63 B5/B14: 69	63/71 B5: 102	80 B5: 100	80 B5: 100	80/90 B5: 120	90 B5: 142 100/112 B5: 142	—
J1s	63 B5: 30 63 B14: 5	63 B5: 20 63 B14: —	63 B5: 7 71 B5: 17	80 B5: 20	80 B5: 20	80/90 B5: —	90 B5: — 100/112 B5: 10	—
J2	71 B5: 122 71 B14: 131	71 B5: 129 71 B14: 138	80 B5: 182 80 B14: 176 90 B5: 182 90 B14: 182	90 B5: 200 90 B14: 200 100 B5: 220 100 B14: 220	90 B5: 200 90 B14: 200 100/112 B5: 220 100/112 B14: 220	100/112 B5 240 100/112 B14: 240	132 B5: 297	132 B5: 353 160 B5: 365
J2s	71 B5: 40 71 B14: 12.5	71 B5: 30 71 B14: 3	80 B5: 37 80 B14: — 90 B5: 37 90 B14: 7	90 B5: 20 90 B14: — 100 B5: 45 100 B14: —	90 B5: 20 90 B14: — 100/112 B5: 45 100/112 B14: —	100/112 B5 25 100/112 B14: —	132 B5: 35	132 B5: 10 160 B5: 35

NOTE: for ball nut dimensions, see ch. 3.8 “Ball nuts dimensions” on page 70

**Screw jacks with travelling ball nut (Mod.B)**

**3.13 Overall dimensions**

**SJ BS Series Mod.B, size 5 - 10 - 25 - 50 - 100 - 150**

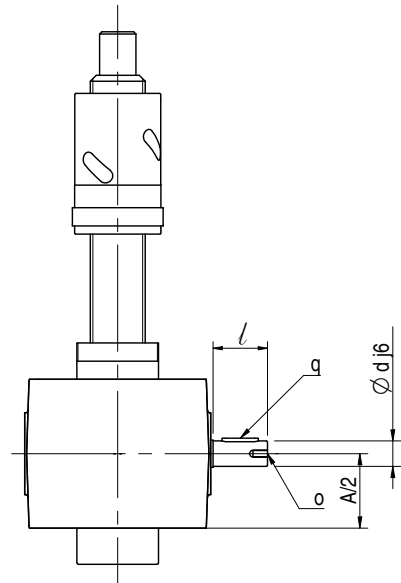
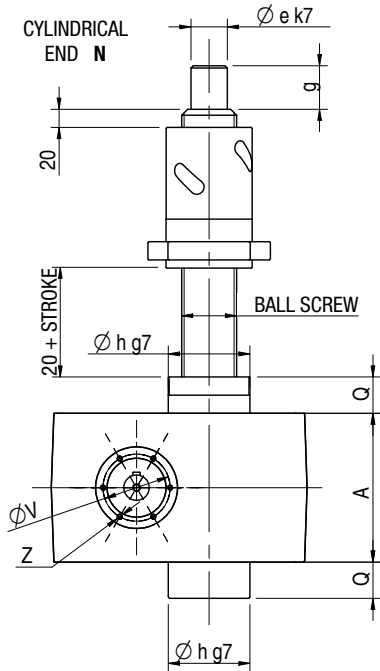

**Vers.1: single input shaft**

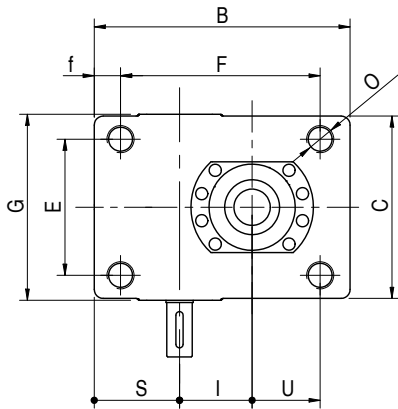

**THREADED FIXING HOLES**

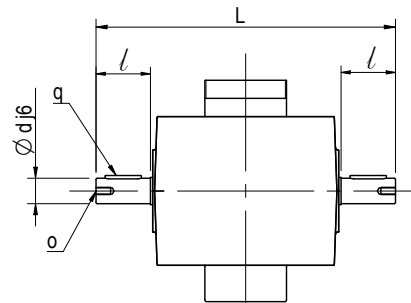

**Vers.2: double input shaft**

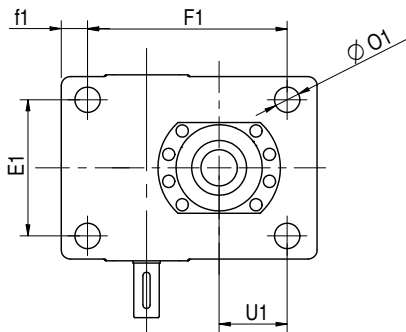

**THROUGH FIXING HOLES**

**Vers.3: flange and hollow shaft IEC**

**Vers.4: flange and hollow shaft IEC + 2<sup>nd</sup> shaft**

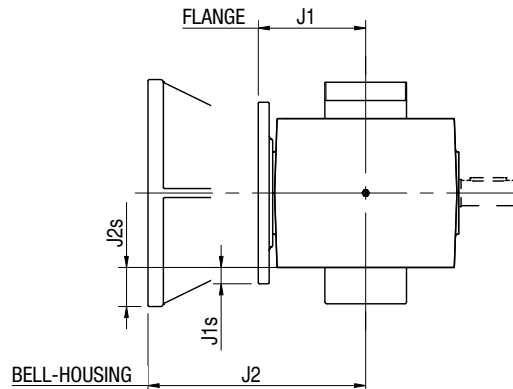

**Vers.5: Vers.1 with bell-housing and coupling IEC**

**Vers.6: Vers.2 with bell-housing and coupling IEC**

3

## Screw jacks with travelling ball nut (Mod.B)

### 3.13 Overall dimensions

#### SJ BS Series Mod.B, size 5 - 10 - 25 - 50 - 100 - 150

SIZE	SJ 5 BS	SJ 10 BS	SJ 25 BS	SJ 50 BS	SJ 100 BS	SJ 150 BS
BALL SCREW	BS 16-20 × P <sub>h</sub>	BS 25 × P <sub>h</sub>	BS 32 × P <sub>h</sub>	BS 40 × P <sub>h</sub>	BS 50 × P <sub>h</sub>	BS 63 × P <sub>h</sub>
A	62	76	82	118	160	164
B	100	110	160	200	220	282
C	86	96	130	160	170	201
E	52	63	81	115	134	150
E1	56	80	102	130	120	150
F	60	78	106	150	175	220
F1	80	85	131	165	180	220
G	90	100	136	165	165	205
I	25	30	50	63	63	80
L	135	165	221.5	269	269	330
O	M8, depth 14	M8, depth 15	M10, depth 15	M12, depth 16	M20, depth 30	M30, depth 45
∅ O1	9	9	11	13	17	28
Q	12	18	23	32	40	40
S	37	40	50	59	74	94
U	21	29	42	63	60	75
U1	28	30	48	60	63	75
∅ V	46	46	64	63	63	74
Z	M6, depth 13 (4 holes at 90°)	M5, depth 10 (6 holes at 60°)	M5, depth 10 (6 holes at 60°)	M6, depth 14 (6 holes at 60°)	M6, depth 14 (6 holes at 60°)	M6, depth 14 (6 holes at 60°)
∅ d	9	14	19	24	24	28
∅ e	12	15	20	30	40	40
f	23	21	36	35	22	29
f1	10	15	17	17	20	29
g	19	24	38	38	48	48
∅ h	30	38.7	46	60	90	90
l	20	30	40	50	50	60
o	M4, depth 8	M6, depth 14	M8, depth 16	M8, depth 16	M8, depth 16	M8, depth 16
q	3×3×15	5×5×20	6×6×30	8×7×40	8×7×40	8×7×40
v	20	20	20	20	20	20
∅ z	14	20	25	35	40	50
J1	56 B5/B14: 57.5	63 B5/B14: 62	63/71 B5: 102	80 B5: 100	80 B5: 100	80/90 B5: 120
J1s	56 B5: 29 56 B14: 9	63 B5: 32 63 B14: 7	63 B5: 29 71 B5: 39	80 B5: 41	80 B5: 20	80/90 B5: 18
J2	63 B5: 98	71 B5: 122 71 B14: 131	80 B5: 182 80 B14: 176 90 B5: 182 90 B14: 182	90 B5: 200 90 B14: 200 100 B5: 220 100 B14: 220	90 B5: 200 90 B14: 200 100/112 B5: 220 100/112 B14: 220	100/112 B5: 240 100/112 B14: 240
J2s	63 B5: 39	71 B5: 42 71 B14: 15	80 B5: 59 80 B14: 19 90 B5: 59 90 B14: 29	90 B5: 41 90 B14: 11 100 B5: 66 100 B14: 21	90 B5: 20 90 B14: — 100/112 B5: 45 100/112 B14: —	100/112 B5: 43 100/112 B14: —

NOTE: for ball nut dimensions, see ch. 3.8 “Ball nuts dimensions” on page 70



**Screw jacks with travelling ball nut (Mod.B)**

**3.13 Overall dimensions**

**SJ BS Series Mod.B, size 200 - 250 - 300 - 400**

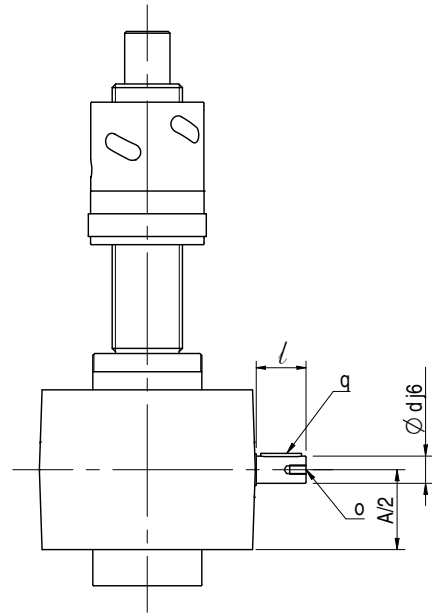
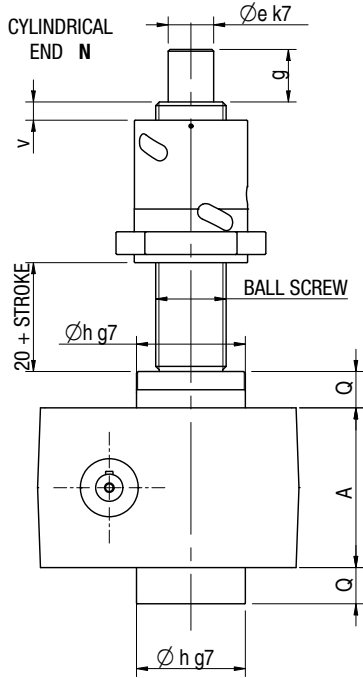

**Vers.1: single input shaft**

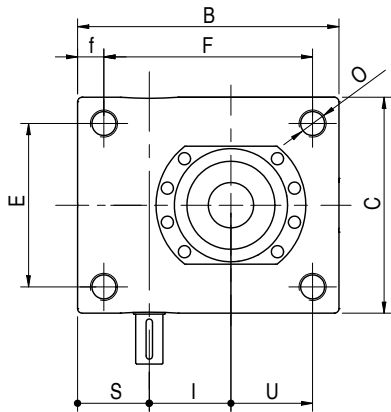

**THREADED FIXING HOLES**

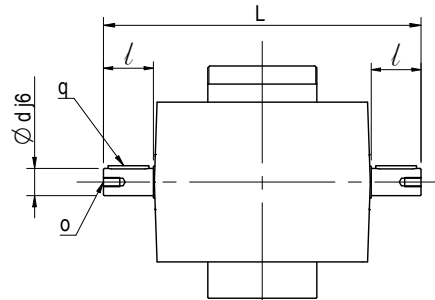

**Vers.2: double input shaft**

**Vers.3: flange and hollow shaft IEC**

**Vers.4: flange and hollow shaft IEC + 2<sup>nd</sup> shaft**

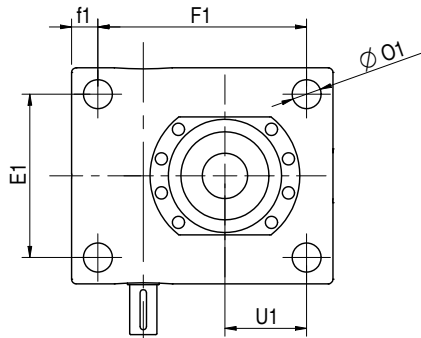

**THROUGH FIXING HOLES**

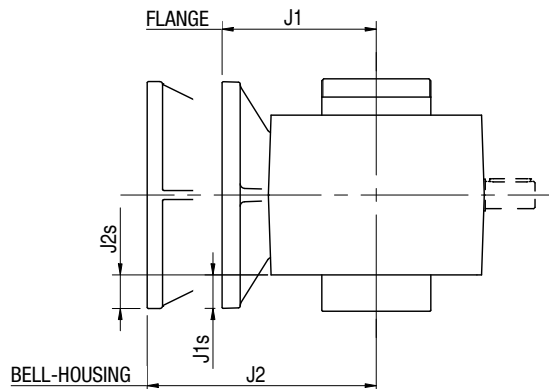

**Vers.5: Vers.1 with bell-housing and coupling IEC**

**Vers.6: Vers.2 with bell-housing and coupling IEC**

3

## Screw jacks with travelling ball nut (Mod.B)

### 3.13 Overall dimensions

#### SJ BS Series Mod.B, size 200 - 250 - 300 - 400

SIZE	SJ 200 BS	SJ 250 BS	SJ 300 BS	SJ 400 BS
BALL SCREW	BS 80 × P <sub>h</sub>	BS 100 × P <sub>h</sub>	BS 100 × P <sub>h</sub>	BS 120 × P <sub>h</sub>
A	176	176	230	270
B	280	280	320	428
C	230	230	250	322
E	180	180	200	230
E1	180	180	200	230
F	230	230	270	355
F1	230	230	270	355
I	90	90	110	140
L	350	350	390	490
O	M30, depth 45	M30, depth 45	M30, depth 45	M30, depth 45
∅ O1	32	32	32	32
Q	40	40	50	50
S	75	75	85	117
U	90	90	100	135
U1	90	90	100	135
∅ d	30	30	40	55
∅ e	50	50	70	85
f	25	25	25	37
f1	25	25	25	37
g	58	58	68	68
∅ h	120	120	150	210
l	55	55	65	75
o	M10, depth 18	M10, depth 18	M10, depth 22	M12, depth 28
q	8×7×45	8×7×45	12×8×55	16×10×60
v	20	20	40	40
∅ z	60	60	80	80
J1	100/112 B5: 170	100/112 B5: 170	—	—
J1s	100/112 B5: 37	100/112 B5: 37	—	—
J2	132 B5: 292	132 B5: 292	—	—
J2s	132 B5: 62	132 B5: 62	—	—

NOTE: for ball nut dimensions, see ch. 3.8 “Ball nuts dimensions” on page 70

**Screw jacks with travelling ball nut (Mod.B)**

**3.13 Overall dimensions**

**HS Series**

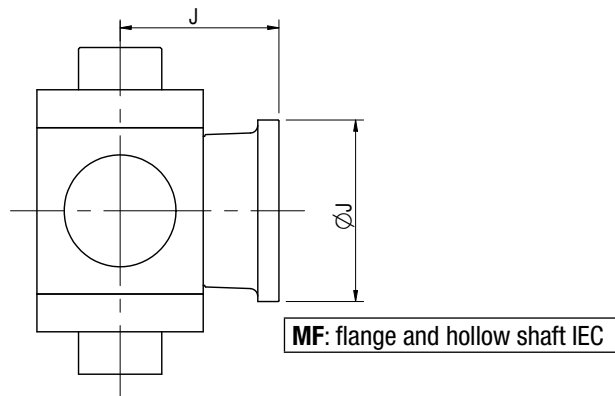
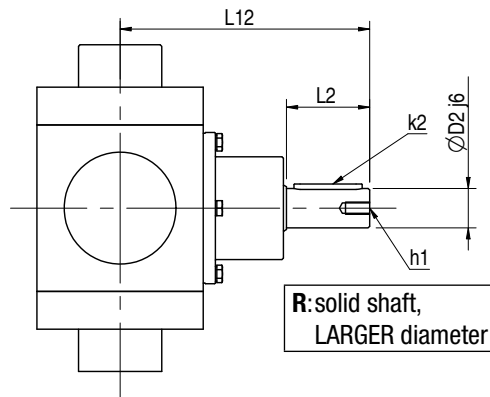
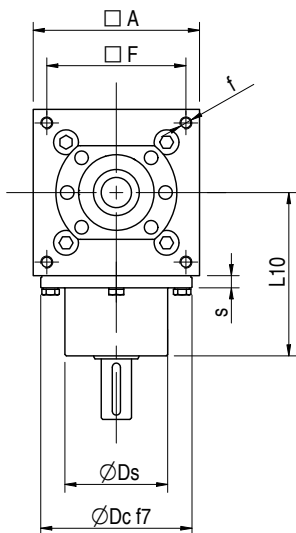
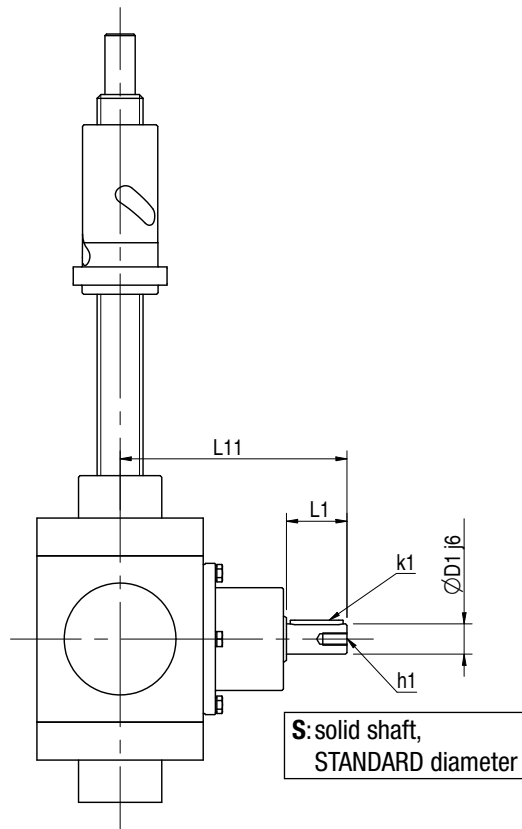
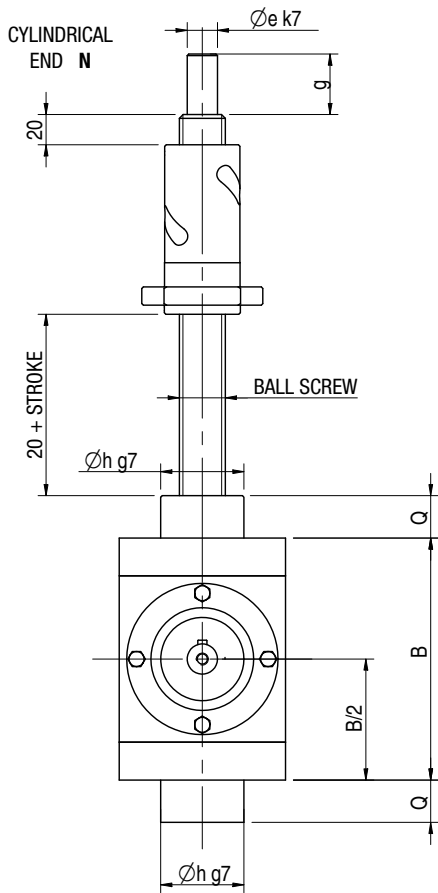

3

## Screw jacks with travelling ball nut (Mod.B)

### 3.13 Overall dimensions

#### HS Series

SIZE	HS 10	HS 25	HS 50	HS 100	HS 150	HS 200
BALL SCREW	BS 25 × P <sub>h</sub>	BS 32 × P <sub>h</sub>	BS 40 × P <sub>h</sub>	BS 50 × P <sub>h</sub>	BS 63 × P <sub>h</sub>	BS 80 × P <sub>h</sub>
□ A	86×86	110×110	134×134	166×166	200×200	250×250
B	122	160	190	230	292	332
∅ D1	16	20	24	32	42	55
∅ D2	24	26	32	45	55	70
∅ Dc	84	100	122	156	185	230
∅ Ds	59	68	80	107	120	152
□ F	74×74	92×92	112×112	140×140	170×170	190×190
L1	30	40	50	65	85	100
L2	50	55	65	90	110	140
L10	82	108	130	150	180	216
L11	114	150	182	217	267	318
L12	134	165	197	242	292	358
Q	25	28	32	42	38	55
∅ e	15	20	30	40	40	50
f	M6, depth 18	M8, depth 25	M12, depth 28	M16, depth 32	M18, depth 46	M24, depth 41
g	24	40	40	45	50	60
∅ h	48	55	65	85	100	125
h1	M6, depth 12	M8, depth 20	M8, depth 20	M10, depth 25	M10, depth 25	M12, depth 25
k1	5×5×25	6×6×35	8×7×45	10×8×60	12×8×80	16×10×90
k2	8×7×40	8×7×45	10×8×55	14×9×80	16×10×100	20×12×120
J	71 B5: 90 80 B5: 100 80 B14: 100	80 B5: 105 80 B14: 105 90 B5: 115 90 B14: 115	90 B5: 125 100-112 B5 135: 100-112 B14: 135	90 B5: 160 100-112 B5: 160 100-112 B14: 160	100-112 B5: 220 132 B5: 220 132 B14: 220	132 B5: 250 160 B5: 250
∅ J	71 B5: 160 80 B5: 200 80 B14: 120	80 B5: 200 80 B14: 120 90 B5: 200 90 B14: 140	90 B5: 200 100-112 B5 250: 100-112 B14: 160	90 B5: 200 100-112 B5: 250 100-112 B14: 160	100-112 B5: 250 132 B5: 300 132 B14: 200	132 B5: 300 160 B5: 350

NOTE: for ball nut dimensions, see ch. 3.8 “Ball nuts dimensions” on page 70

## Screw jacks with travelling ball nut (Mod.B)

### 3.14 Electric motors fitting

#### IEC electric motors

MA BS Series		MA 5 BS	MA 10 BS	MA 25 BS	MA 50 BS	MA 80 BS	MA 150 BS	MA 200 BS	MA 350 BS
63	B5	F	F	F					
	B14	F	F						
71	B5	B	B	F	F	F			
	B14	B	B	F					
80	B5			B	F	F	F		
	B14			B					
90	B5			B	B	B	F	F	
	B14			B	B	B			
100 - 112	B5				B	B	B	F	
	B14				B	B	B		
132	B5							B	B
160	B5								B

SJ BS Series		SJ 5 BS	SJ 10 BS	SJ 25 BS	SJ 50 BS	SJ 100 BS	SJ 150 BS	SJ 200 BS	SJ 250 BS
56	B5	F							
	B14	F							
63	B5	B	F	F					
	B14		F						
71	B5		B	F	F	F			
	B14		B	F					
80	B5			B	F	F	F		
	B14			B					
90	B5			B	B	B	F		
	B14			B	B	B			
100 - 112	B5				B	B	B	F	F
	B14				B	B	B	B	B
132	B5							B	B

HS Series		HS 10	HS 25	HS 50	HS 100	HS 150	HS 200
71	B5	F					
80	B5	F	F				
	B14	F	F				
90	B5		F	F	F		
	B14		F	F			
100 - 112	B5			F	F	F	
	B14			F	F		
132	B5					F	F
	B14					F	
160	B5						F

F - IEC flange with hollow shaft

B - IEC bell-housing with coupling

#### LINEARMECH Brushless Servomotors

Ball screw jacks can be equipped with Linearmech Brushless Servomotors BM Series with metric flange dimensions, according to IEC 34-7, UNEL 05513 regulations. Possible fittings are described below:

Servomotor	Serie MA	Serie SJ	Serie HS
BM 45 L IEC	-	SJ 5 BS	
BM 63 S IEC	MA 5 BS , MA 10 BS	SJ 10 BS	
BM 63 L IEC	MA 5 BS , MA 10 BS, MA 25 BS	SJ 10 BS , SJ 25 BS	
BM 82 S IEC	MA 25 BS	SJ 25 BS	HS 10 , HS 25
BM 82 L IEC	MA 25 BS	SJ 25 BS	HS 10 , HS 25
BM 102 S IEC	MA 25 BS , MA 50 BS , MA 80 BS	SJ 25 BS , SJ 50 BS , SJ 100 BS	HS 25 , HS 50
BM 102 L6 IEC	MA 25 BS , MA 50 BS , MA 80 BS	SJ 25 BS , SJ 50 BS , SJ 100 BS	HS 25 , HS 50
BM 102 L8 IEC	MA 25 BS , MA 50 BS , MA 80 BS	SJ 25 BS , SJ 50 BS , SJ 100 BS	HS 25 , HS 50

For technical data of servomotors, please refer to ch.5 "LINEARMECH servo motors" on page 115.

Flanges and bell-housings to specific drawing for hydraulic motors or servo motors are available on request.

# Screw jacks with travelling ball nut (Mod.B)

## 3.15 Accessories

### Bellows

In applications with particular environment conditions, bellows protect the screw from contaminants.

The usually supplied bellows are circular, sewn (double seam), in NYLON with a PVC outside and inside coating. For special application requirements, different executions or materials can be supplied on request.

The bellows cause changes to the retracted and extended lengths and screw jack overall dimensions stated in the catalogue. On request, orders will be acknowledged with a screw jack drawing giving exact dimensions.

Usually, bellows are fitted on both sides: between the screw jack housing and the ball nut and between the nut and the ball screw end. Anyway, some applications require only one of the two bellows.

The attachments dimensions of the bellow between the screw jack housing and the nut are determined by the screw jack parts dimensions, where the bellow is fixed, while the attachments dimensions of the bellow between ball nut and screw end depend on the application, because the bellow is directly in contact with the application's structure.

The protective bellow is available for all screw jack series (MA BS, SJ BS, HS).

Ordering code: **B**

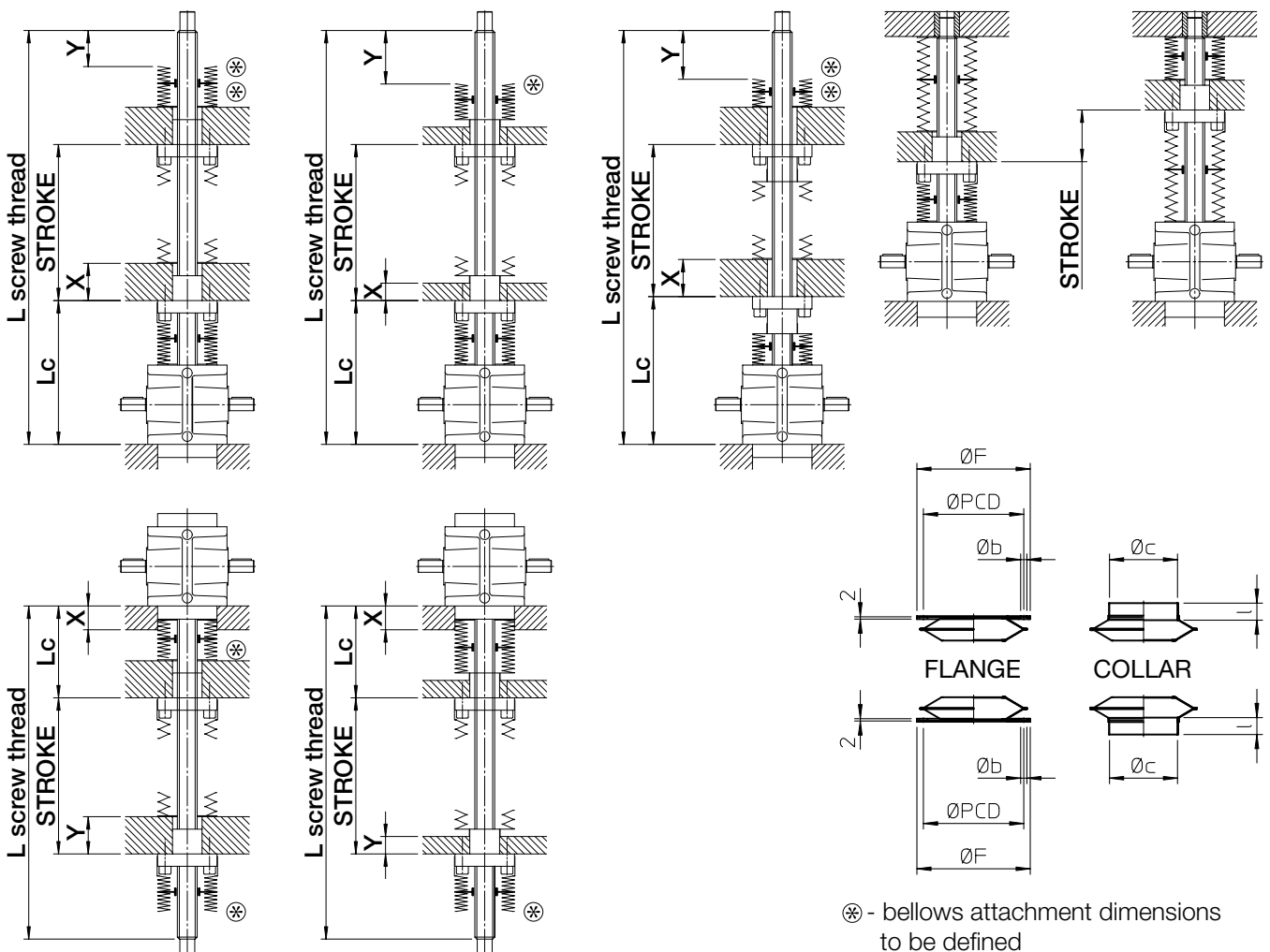

## Screw jacks with travelling ball nut (Mod.B)

### 3.15 Accessories

#### Worm wheel rotation detector

Available for screw jacks MA BS and SJ BS Series only (not for HS Series).

Some applications require the possibility to verify if the worm wheel rotates while the worm shaft is moving in order to get information about the good condition and functioning of the worm wheel toothing.

A cylindrical element, machined in order to have a “crown” of empty and full spaces, is fixed to the worm wheel creating a phonic wheel that, while rotating, activates a corresponding proximity switches. As output of such proximity switch, activated and deactivated by the alternation of empty and full spaces, a “train” of impulses is generated which confirms the rotation of the worm wheel. On the contrary, the constant output signal of the proximity switch means the stop of the worm wheel.



#### Safety nut

The safety nut is a back-up feature to prevent the load dropping in an uncontrolled manner in case of working nut balls failure. This can be caused by overload or by achieving a critical wear level.

The safety nut is an extension to the main nut and changes the screw jack overall dimensions. It works with one particular load direction only. Its position as regards the main nut is therefore conditioned by the load direction.

The safety nut does not have balls inside, but a thread helix that traces the ball truck on the screw. With a not worn out main nut, the thread of the nut does not touch the screw; in case the balls of the main nut should fail, the safety nut will touch the screw and sustain the load, causing a slithering between the screw and the safety nut threads. The safety nut is made in steel and therefore, in case it is activated, it is then necessary to replace both screw and main nut.

The safety nut is available for all screw jack series (MA BS, SJ BS, HS).

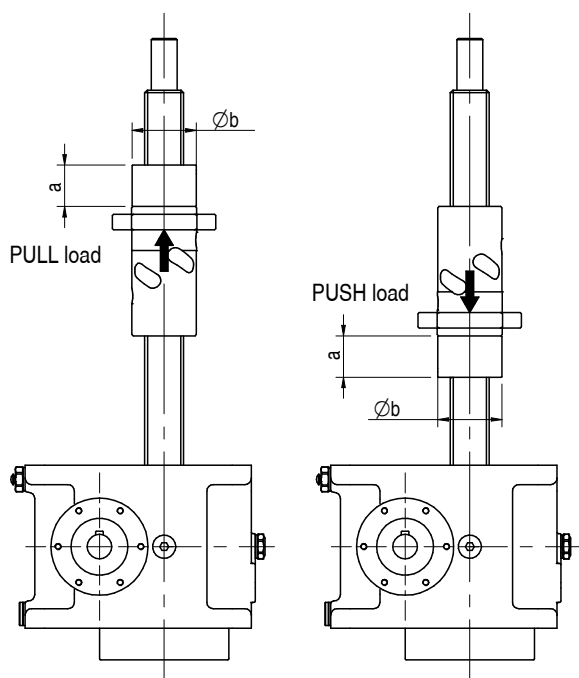

Ball screw diameter	16	20	25	32	40
a	16	20	25	32	40
Øb	28	36	40	50	63

Ball screw diameter	50	63	80	100	120
a	20	20	20	20	20
Øb	75	90	105	150	190

Ordering code: **SBC push** safety nut for PUSH load

Ordering code: **SBC pull** safety nut for PULL load

## Screw jacks with travelling ball nut (Mod.B)

### 3.15 Accessories

#### ROTARY ENCODER Code ENC.4

Hall-effect encoder, incremental, bi-directional  
 Resolution: 4 pulses per revolution  
 Output: PUSH-PULL  
           2 channels (A and B, phase difference 90°)  
 Input voltage: (8 ... 32) Vdc  
 Max. commutable current ( $I_{out}$ ): 100 mA  
 Max output voltage drop:  
     with load connected to 0 and  $I_{out} = 100$  mA: 4.6 V  
     with load connected to + V and  $I_{out} = 100$  mA: 2 V  
 Protection:  
     against short circuit  
     against input polarity inversion  
     against any incorrect output connection  
 Cable length: 1.3 m  
 Protection: IP 55

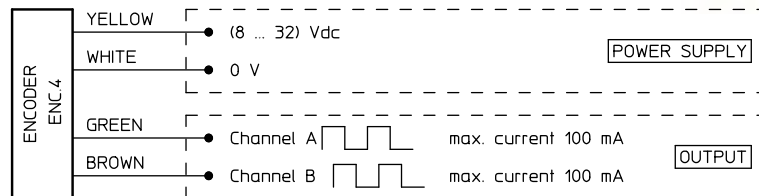

The encoder ENC.4 is available for all screw jack series (MA BS, SJ BS, HS).

Ordering code: **ENC.4**

#### ROTARY ENCODER Code EH53

Optical encoder, incremental, bi-directional  
 Resolution: 100 or 500 pulses per revolution  
 Output: PUSH-PULL  
           2 channels (A and B, phase difference 90°)  
           channel ZERO  
 Input voltage: (8 ... 24) Vcc  
 No-load current: 100 mA  
 Max. commutable current: 50 mA  
 Cable length: 0.5 m  
 Protection: IP 54

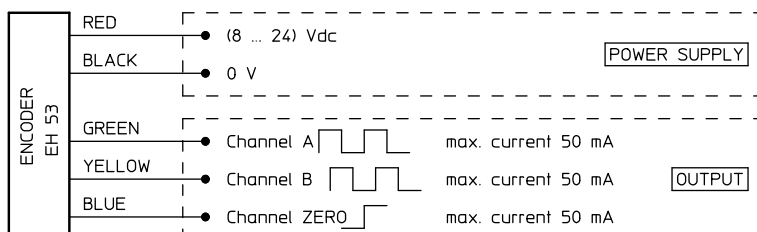

The encoder ENC.4 is available for all screw jack series (MA BS, SJ BS, HS).

Ordering code: **EH 53**



## Screw jacks with travelling ball nut (Mod.B)

### 3.15 Accessories - MA BS Series

#### Raised cover

The housing of the screw jacks MA BS Mod.B is enclosed inside two threaded covers, one on the top and one on bottom. Screw jacks Mod.B have always raised cover (CA) mounted on the screw jack housing on the opposite side of the acme screw, to protect the rotating screw threaded end. The threaded cover on the screw side is always supplied as low cover (CB) in standard execution, raised cover execution available on request. The raised cover CA with toleranced outer diameter acts as a centring diameter of the screw jack inside the machine structure.

Ordering code: **CA - CA**



#### Trunnion mount

The trunnion mount is bolted to either the top or the bottom of the screw jack housing and allows the screw jack pivoting around the axis defined by the trunnion mount's lateral pins.

NOTE: the part of the machine where the nut is fixed must have two cylindrical pins (or holes) with axes parallel to the trunnion mount pivots axis.

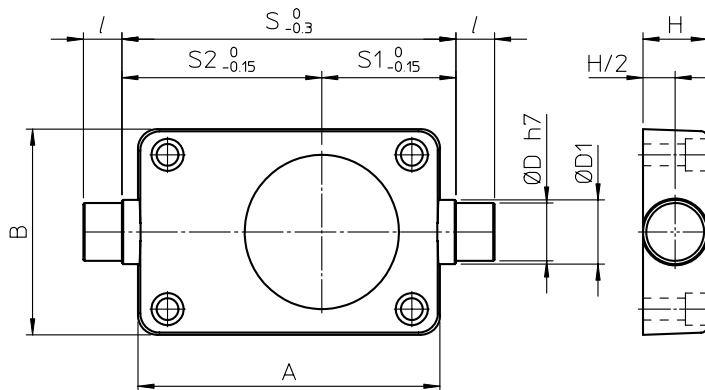

	MA 5 BS	MA 10 BS	MA 25 BS	MA 50 BS	MA 80 BS	MA 150 BS	MA 200 BS	MA 350 BS
A	124	140	175	235	235	276	330	415
B	80	105	130	160	160	200	230	300
ØD	15	20	25	45	45	50	70	80
ØD <sub>1</sub>	20	25	30	50	50	60	80	90
H	20	25	30	50	50	60	80	90
l	15	20	20	30	30	40	45	60
S	130	145	200	260	260	305	360	440
S <sub>1</sub>	50.5	56.5	80	104.5	104.5	119.5	132	181.5
S <sub>2</sub>	79.5	88.5	120	155.5	155.5	185.5	228	258.5
mass [kg]	0.8	1.6	3.2	9.8	9.8	15.8	29	52

Ordering code: **SC (screw side)**

screw jacks with SC fixed on the screw side

Ordering code: **SC (opposite screw side)**

screw jacks with SC fixed on opposite screw side

# Screw jacks with travelling ball nut (Mod.B)

## 3.15 Accessories - SJ BS Series

### Screw jack housing fixing holes

On the gear housing of screw jack SJ Series there are fixing holes, which can be threaded tapped holes (on both housing fixing planes) or through holes.

The threaded holes position on the fixing plane can differ from the through holes position.

Ordering code: **FF** threaded holes (STANDARD)

Ordering code: **FP** through holes (ON REQUEST)

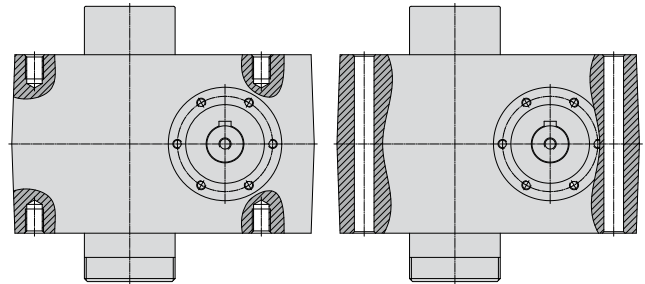

### Trunnion mount

The trunnion mount is bolted to either the top or the bottom of the screw jack housing and allows the screw jack pivoting around the axis defined by the trunnion mount's lateral pins.

NOTE: the part of the machine where the nut is fixed must have two cylindrical pins (or holes) with axes parallel to the trunnion mount pivots axis.

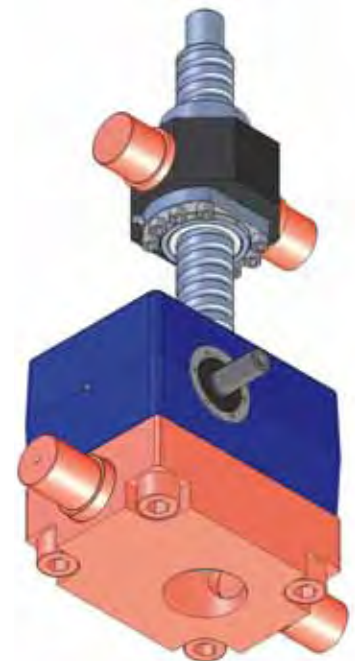
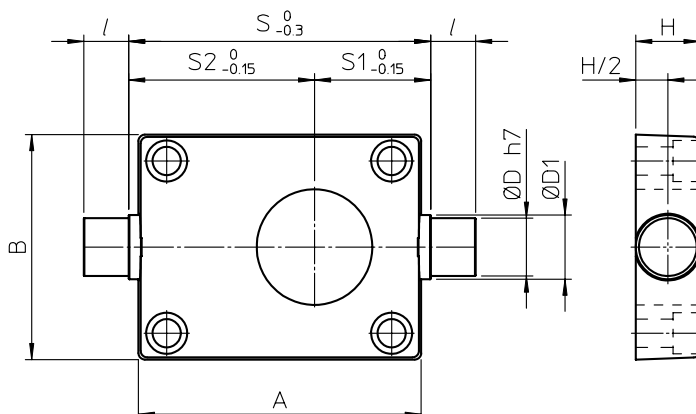

3

	SJ 5 BS	SJ 10 BS	SJ 25 BS	SJ 50 BS	SJ 100 BS	SJ 150 BS	SJ 200 BS	SJ 250 BS	SJ 300 BS
A	100	110	160	200	220	276	280	280	312
B	86	96	130	160	170	200	230	230	242
ØD	15	20	25	35	45	60	70	70	70
ØD <sub>1</sub>	20	25	30	40	50	70	90	90	85
H	20	25	30	40	50	80	100	100	100
l	15	20	20	30	35	65	75	75	75
S	105	115	185	215	235	305	300	300	350
S <sub>1</sub>	40.5	42.5	72.5	85.5	90.5	119.5	125	125	140
S <sub>2</sub>	64.5	72.5	112.5	129.5	144.5	185.5	175	175	210
mass [kg]	1.1	1.8	3.4	7.3	9	30	40	40	40

Ordering code: **SC (screw side)** screw jacks with SC fixed on the screw side

Ordering code: **SC (opposite screw side)** screw jacks with SC fixed on opposite screw side

## Screw jacks with travelling ball nut (Mod.B)

### 3.16 Ordering code

#### MA BS Series Mod.B

MA	50	BS 40 × 10	Mod.B	RL	Vers. 3 (80 B5)	U-RH		
1	2	3	4	5	6	7		
C300	IT 5	SFN-D.40.10.5R	N	B2	B1	CB / CA		
8	9	10	11					
...								
12								
...								
13								
AC	3-phase	brake motor	0.75 kW	4-pole	230/400 V	50 Hz	IP 55	Ins. F
14								

1	MA (screw jack MA BS Series)	
2	Screw jack size	
5 ... 350		page 65, 66 - 67
3	Ball screw	
BS diameter × lead		page 68 - 69
4	Mod.B (Model: travelling nut)	
5	Worm gear ratio	page 66 - 67
6	Input version	
Vers.1, Vers.2, Vers.3, Vers.4, Vers.5, Vers.6		page 9
7	Screw jack mounting and input shaft position	
U-RH, U-LH, D-RH, D-LH, H-RH, H-LH		page 9
8	Screw jack stroke length (ex.: C300 = 300 mm stroke)	
9	Ball screw accuracy grade	
IT 3 or IT 5: whirled ball screw		page 68
IT 7: rolled ball screw		page 69
10	Ball nut	
Nut code		page 70 - 71
11	Accessories	
N	Screw end	page 82
B <sub>1</sub> , B <sub>2</sub>	Bellows	page 91
CB, CA	Low cover, raised cover	page 94
SBC pull (push)	Safety nut for PULL (or PUSH) load	page 92
	Worm wheel rotation detector	page 92
SC	Trunnion mount	page 94
12	Other accessories	
example: encoder (with all relevant data)		page 93
13	Other specifications	
example: lubricant for low temperature		
14	Motor data	
15	Filled in selection sheet	page 97
16	Application layout	

## Screw jacks with travelling ball nut (Mod.B)

UPWARD mounting

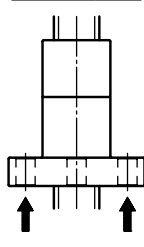
SBC   

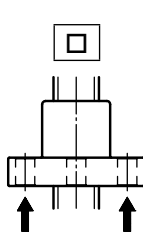

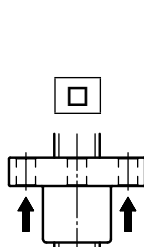
SBC   

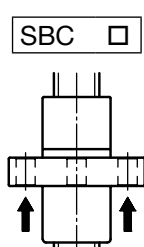

PULL LOAD

PUSH LOAD

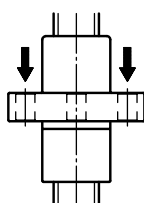

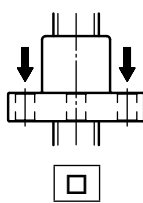

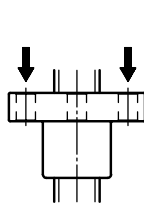

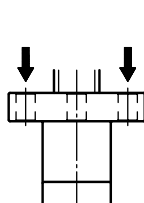

SBC

SBC

N   
 B2   
 B1   
 CA   
 CB

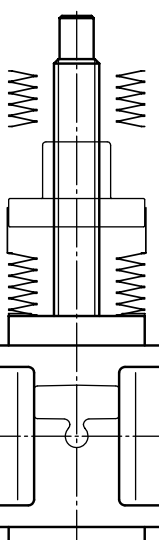

Vers. \_\_\_\_\_  
 CA

UPWARD mounting

DOWNWARD mounting

CA  
 Vers. \_\_\_\_\_

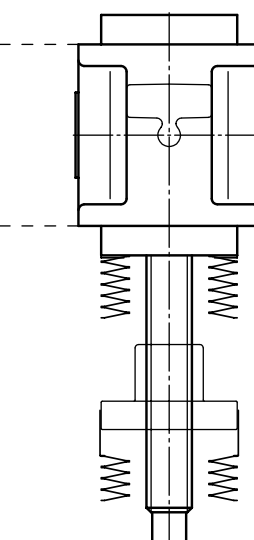

CB  
 CA  
 B1  
  
 B2  
 N

SBC

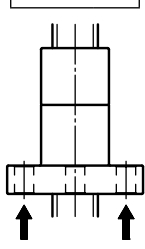

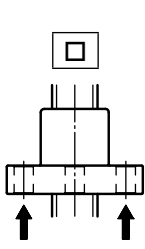

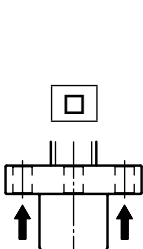

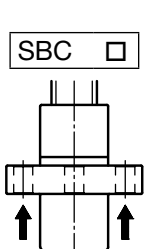
SBC   

PUSH LOAD

PULL LOAD

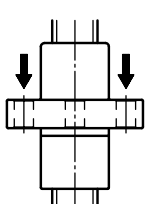

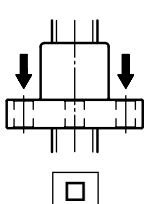

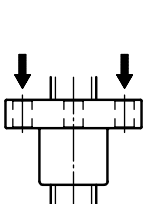

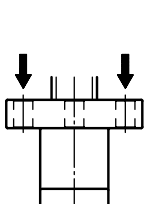

SBC

SBC

SBC   
 SBC

DOWNWARD mounting

3

97

## Screw jacks with travelling ball nut (Mod.B)

### 3.16 Ordering code

#### SJ BS Series Mod.B

SJ	50	BS 40 × 10	Mod.B	RL	Vers. 3 (80 B5)	U-RH	FF
1	2	3	4	5	6	7	8

C300	IT 5	SFN-D.40.10.5R	N B2 B1
9	10	11	12

Series
13

...
14

AC	3-phase	brake motor	0.75 kW	4-pole	230/400 V	50 Hz	IP 55	Ins. F
14								

1 SJ (screw jack SJ BS Series)

2 Screw jack size

5 ... 300

page 65, 66 - 67

3 Ball screw

BS diameter × lead

page 68 - 69

4 Mod.B (Model: travelling nut)

5 Worm gear ratio

page 66 - 67

6 Input version

Vers.1, Vers.2, Vers.3, Vers.4, Vers.5, Vers.6

page 9

7 Screw jack mounting and input shaft position

U-RH, U-LH, D-RH, D-LH, H-RH, H-LH

page 9

8 Gear box fixing holes

FF, FP

page 84, 86

9 Screw jack stroke length (ex.: C300 = 300 mm stroke)

10 Ball screw accuracy grade

IT 3 or 5: whirled ball screw

page 68

IT 7: rolled ball screw

page 69

11 Ball nut

Nut code

page 70 - 71

12 Accessories

N Screw end

page 84, 86

B<sub>1</sub>, B<sub>2</sub> Bellows

page 91

SBC pull (push) Safety nut for PULL (or PUSH) load

page 92

SC Trunnion mount

page 95

Worm wheel rotation detector

page 92

13 Other accessories

example: encoder (with all relevant data)

page 93

14 Other specifications

example: lubricant for low temperature

15 Motor data

16 Filled in selection sheet

page 99

17 Application layout

**Screw jacks with travelling ball nut (Mod.B)**

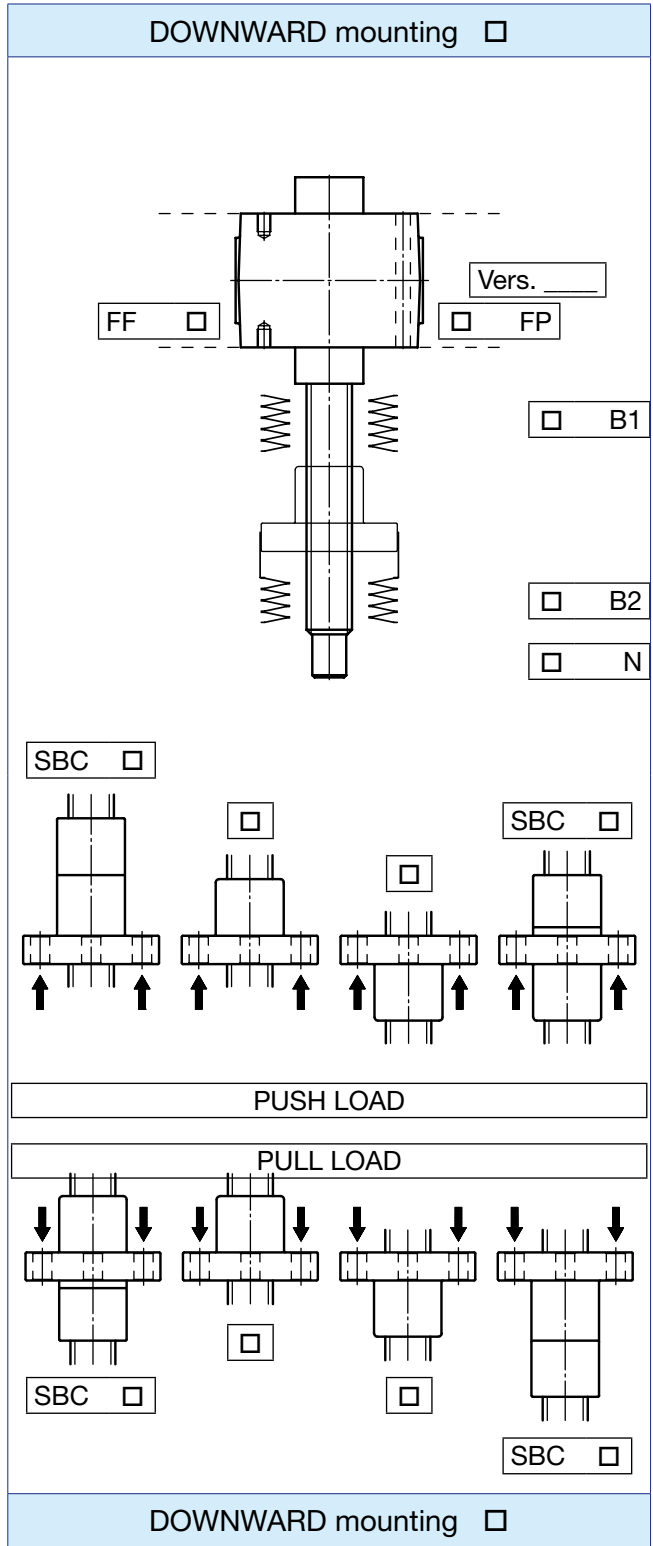
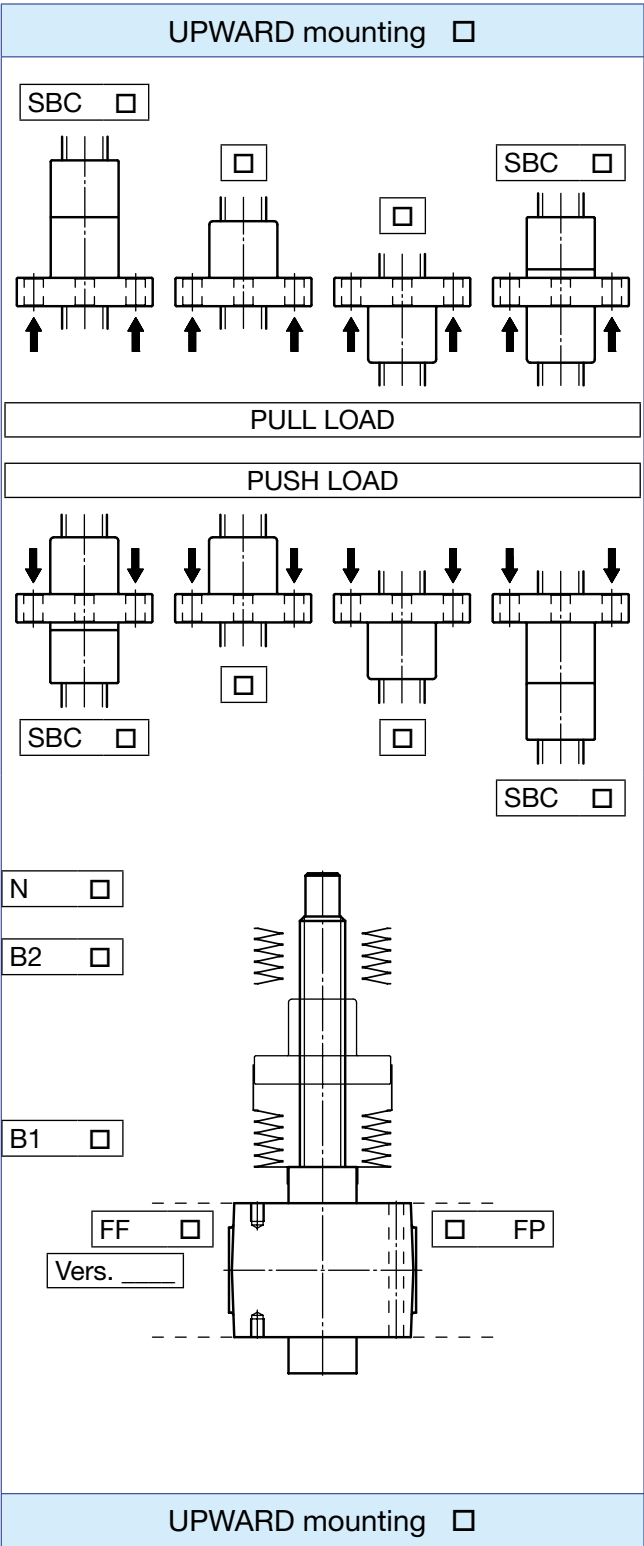

## Screw jacks with travelling ball nut (Mod.B)

### 3.16 Ordering code

#### HS Series

HS	50	R2	BS 40 × 10	S	scheme 10	S 180°	U	lato B
1	2	3	4	5	6	7	8	9

C300	IT 5	SFN-D.40.10.5R	N B2 B1
10	11	12	13

...
14

...
15

AC	3-phase	brake motor	0.75 kW	4-pole	230/400 V	50 Hz	IP 55	Ins. F
16								

1	HS (screw jack HS Series)	
2	Screw jack size	
10 ... 200		page 65, 66 - 67
3	Worm gear ratio	
R1, R1.5, R2, R3, R4		page 66 - 67
4	Ball screw	
BS diameter × lead		page 68 - 69
5	Main input	
S, R, MF, MA		page 10
6	Kinematics scheme	
scheme 10, scheme 20		page 10
7	Additional output shaft (version and position)	
S, R - 90°, 180°, 270°		page 11
8	Screw jack mounting position	
U, D, H		page 11
9	Screw jack fixing side	
side A - B - C - D - E - F		page 12
10	Screw jack stroke length (ex.: C300 = 300 mm stroke)	
11	Ball screw accuracy grade	
IT 3 or 5: whirled ball screw		page 68
IT 7: rolled ball screw		page 69
12	Ball nut	
Nut code		page 70 - 71
13	Accessories	
N	Screw end	page 88
B <sub>1</sub> , B <sub>2</sub>	Bellows	page 91
SBC pull (push)	Safety nut for PULL (or PUSH) load	page 92
14	Other accessories	
example: encoder (with all relevant data)		page 93
15	Other specifications	
16	Motor data	
17	Application layout	

**Screw jacks with travelling ball nut (Mod.B)**

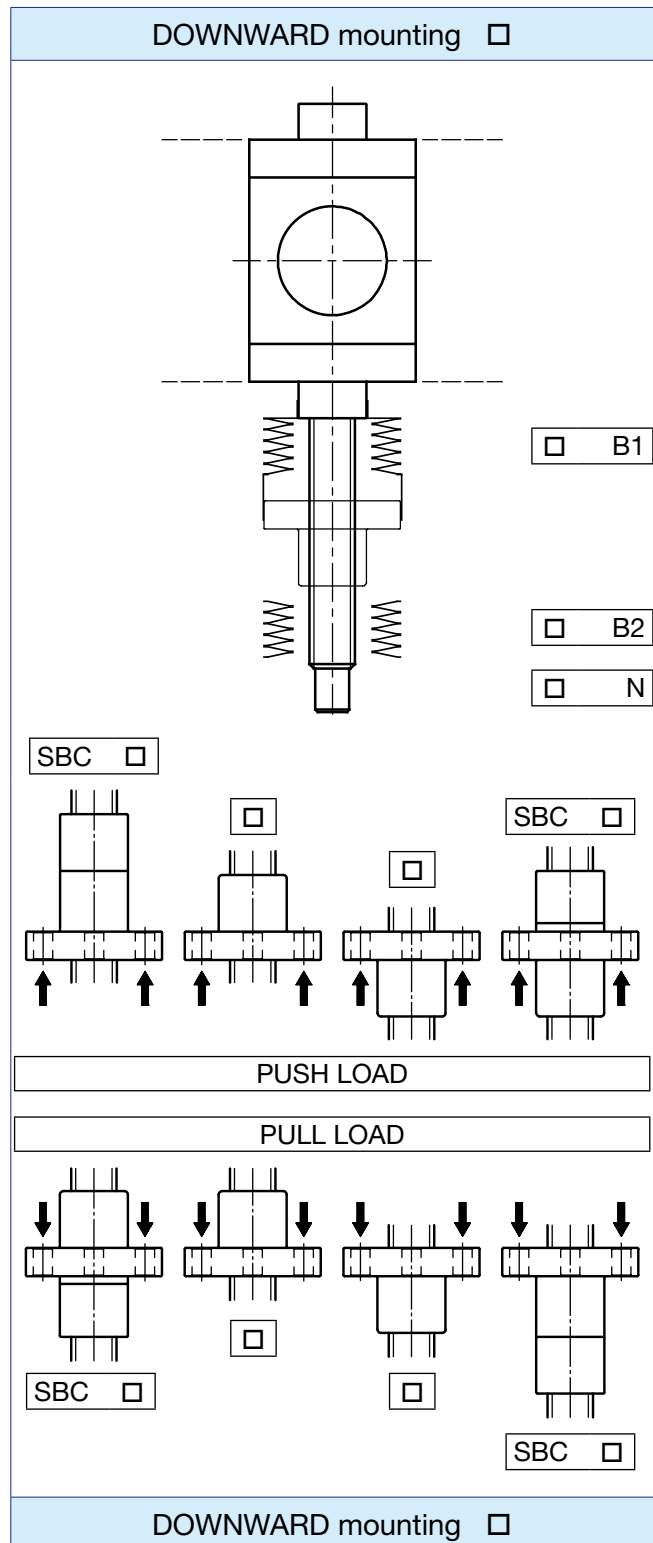
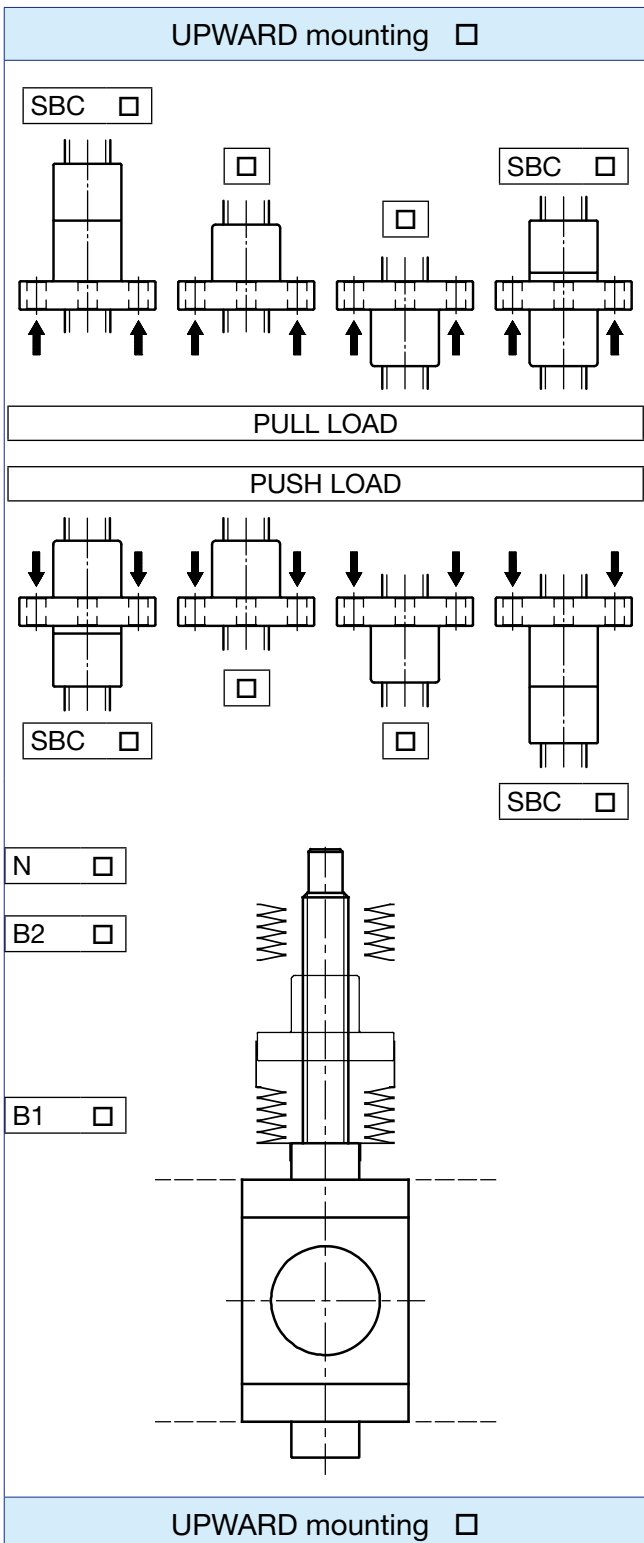

3