

2.9.2	Lubricants	27
2.9.3	Special lubricants	28
2.9.4	Quantity	29
2.10	MOMENTS OF INERTIA	30

3. DIMENSIONS

3.1	REDUCERS/GEARED MOTORS	31
3.1.1	HA31	31
3.1.2	HA.1	32
3.1.3	CHA.1	33
3.1.4	IHA.1	34
3.1.5	HA.2	35
3.1.6	CHA.2	37
3.1.7	IHA.2	39
3.1.8	HA.3	41
3.1.9	CHA.3	43
3.1.10	IHA.3	45
3.1.11	HR..1	47
3.1.12	CHR..1	49
3.1.13	IHR..1	51
3.1.14	H..2/3	53
3.1.15	CH..2/3	55
3.1.16	IH..2/3	57
3.2	ELECTRIC MOTORS	59
3.2.1	Electric motors	59
3.2.2	Standard high efficiency (TS), high (TH) and premium (TP) motors	61
3.2.3	Nominal power - [kW]	62
3.3	WEIGHT	63
3.4	END SHAFT	65

4. ACCESSORIES AND OPTIONS

4.1	OUTPUT FLANGE	66
4.2	BACKSTOP DEVICE	67
4.3	REINFORCED OIL SEALS FOR OUTPUT SHAFT	69

3.1.1 HA31

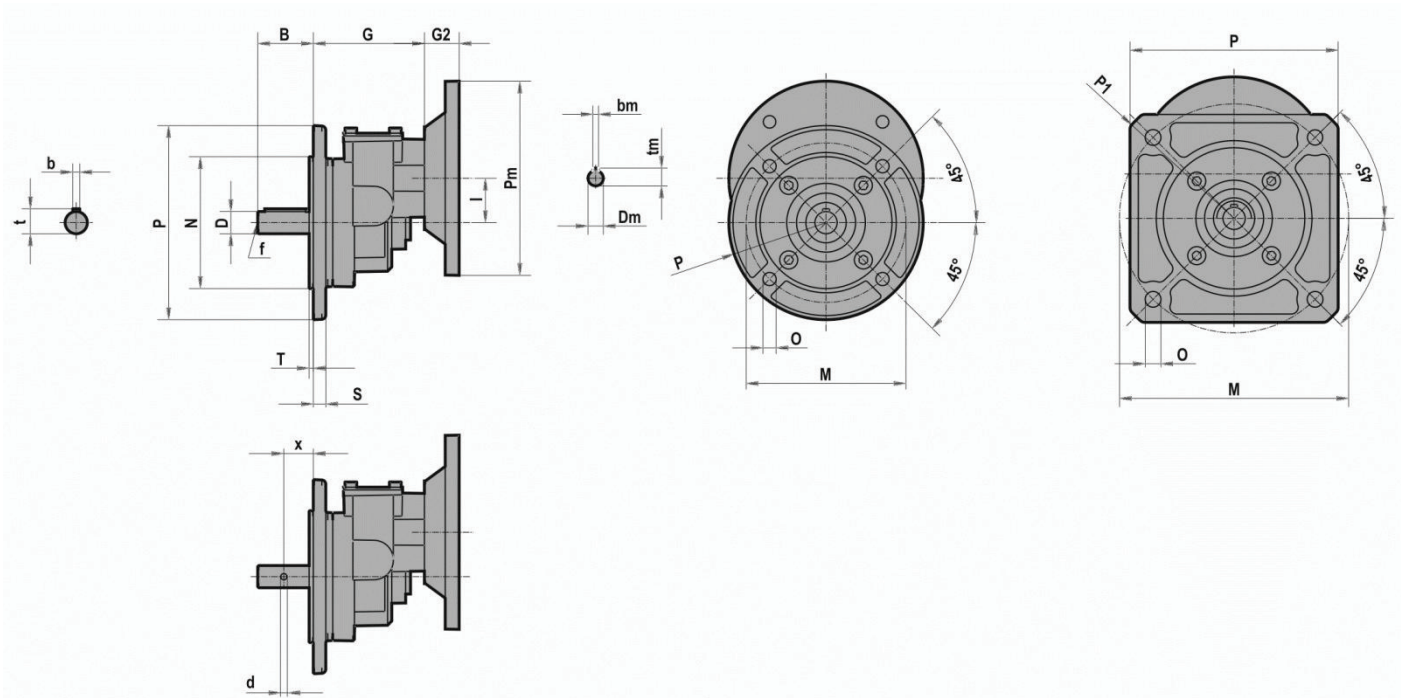

	D	B	b	t	x	d	f	G	I
HA31	11 j6	23	4	12,5	-	-	-	80	32
	14 j6	30	5	16	-	-	M6		
	16 j6	40	5	18	-	-	M6		
	19 j6	40	6	21,5	-	-	M6		
	16 j6	50	-	-	29	7	-		
	19 0/-0,2	60	-	-	37	6,5	-		
	19,7 +/- 0,05	100	-	-	50	6	M8		
	20 j6	75	-	-	45	6	-		

	P	P1	M	N	O	S	T
HA31	116	150	127	-	M8 (n.4)	-	-
	138	160	127	-	M8 (n.4)	-	-
	140	-	115	95 f7	9,5 (n.4)	9	3
	150	200	165	-	11 (n.4)	-	-

IEC	Pm x Dm	G2
063	140x11	25
071	160x14	32
080	200x19	42

B5	Pm	Dm	bm	tm
063	140	11	4	12,8
071	160	14	5	16,3
080	200	19	6	21,8

3.1.2 HA.1

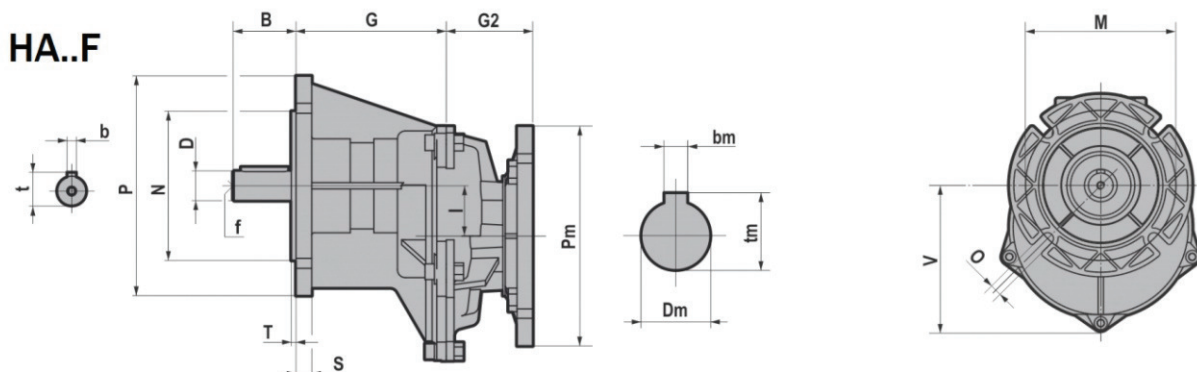
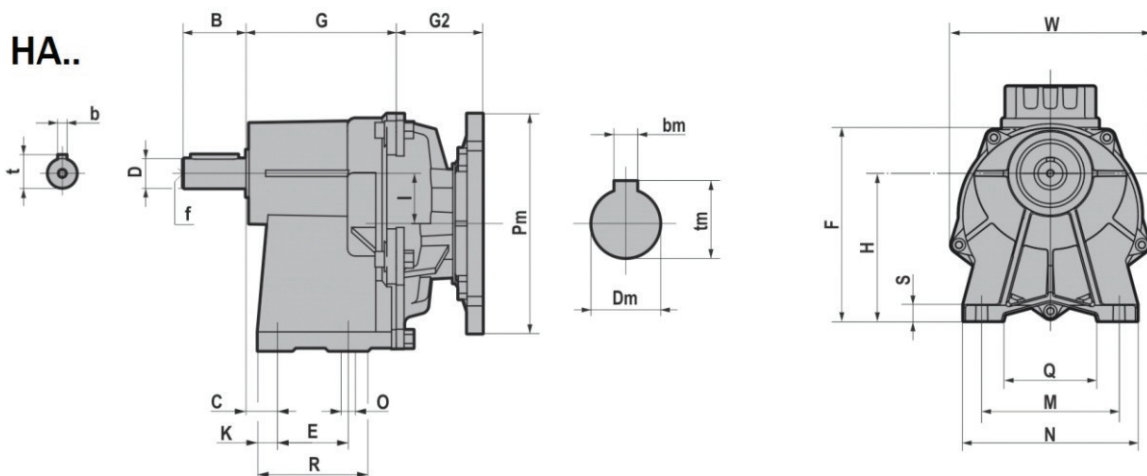

	D j6	B	C	E	F	G	H	I	K	M	N	O	Q	R	S	W	b	t	f
HA41/F	16	40	20	45	151	95,5	113	32	12,5	105	130	9	75	70	12	152	5	18	M6
	19																6	21,5	M6
HA51/F	24	50	6	70	169	104	130	32	15	150	180	11	115	100	12	152	8	27	M8
HA61/F	28	60	7,5	70	219,5	129	165	47,5	20	165	200	11	120	110	15	218	8	31	M8
	24																8	27	M8

	M	N f8	O	P	S	T	V
HA41F	115	95	9 (n.4)	140	10	3	111,5
HA51F	130	110	9 (n.4)	160	10	3,5	111,5
HA61F	165	130	11 (n.4)	200	15	3,5	161,5

IEC	Pm x Dm		G2	
	Pm x Dm	Pm x Dm	HA41/F - HA51/F	HA61/F
063	140X11	090x11	55	/
071	160X14	105x14	55	/
080	200X19	120x19	86	87,5
090	200X24	140x24	86	87,5
100-112	250X28	160x28	/	87,5

B5	Pm	Dm	bm	tm
063	140	11	4	12,8
071	160	14	5	16,3
080	200	19	6	21,8
090	200	24	8	27,3
100	250	28	8	31,3
112	250	28	8	31,3

B14	Pm	Dm	bm	tm
071	105	14	5	16,3
080	120	19	6	21,8
090	140	24	8	27,3
100	160	28	8	31,3
112	160	28	8	31,3

3.1.3 CHA.1

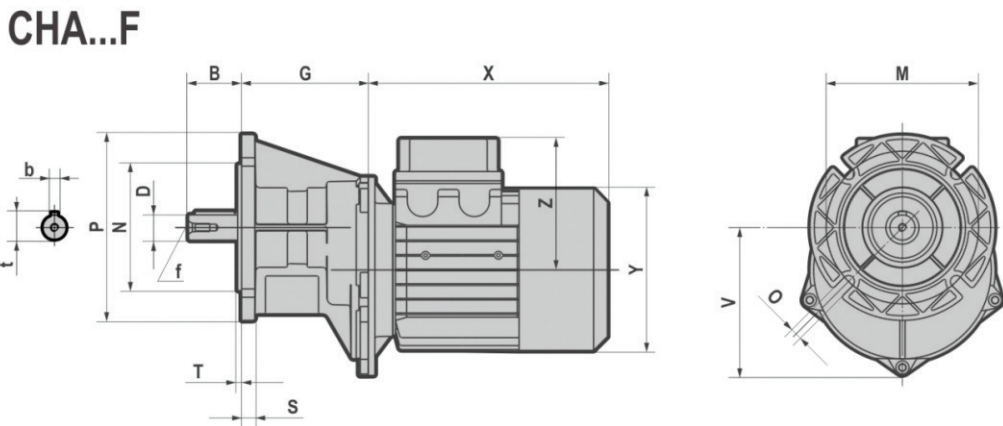
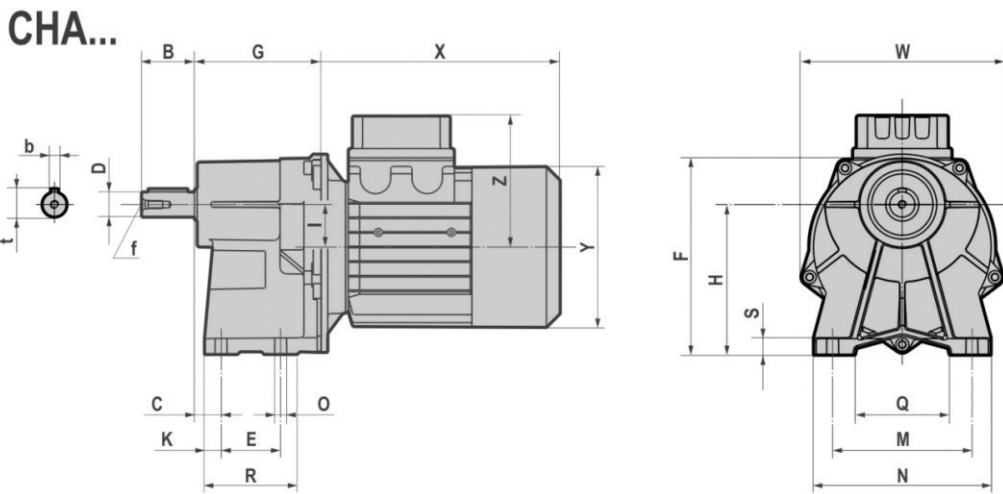

	D j6	B	C	E	F	G	H	I	K	M	N	O	Q	R	S	W	b	t	f
CHA41/F	16	40	20	45	151	95,5	113	32	12,5	105	130	9	75	70	12	152	5	18	M6
	19																6	21,5	M6
CHA51/F	24	50	6	70	169	104	130	32	15	150	180	11	115	100	12	152	8	27	M8
CHA61/F	28	60	7,5	70	219,5	129	165	47,5	20	165	200	11	120	110	15	218	8	31	M8
	24	50															8	27	M8

	M	N f8	O	P	S	T	V
CHA41F	115	95	9 (n.4)	140	10	3	111,5
CHA51F	130	110	9 (n.4)	160	10	3,5	111,5
CHA61F	165	130	11 (n.4)	200	15	3,5	161,5

	T (IE1 - IE2)							
		063	071	080	090S	090L	100	112
CHA41/F CHA51/F	X	180	205	223	232	257	/	/
	Y	121	139	158	173	173	/	/
	Z	104	112	122	130	130	/	/
CHA61/F	X	/	/	218	232	257	290	302
	Y	/	/	158	173	173	191	211
	Z	/	/	122	130	130	139	154

	TB (IE1 - IE2)							
		063	071	080	090S	090L	100	112
CHA41/F CHA51/F	X	238	271	294	309	334	/	/
	Y	121	139	158	173	173	/	/
	Z	119	129	137	157	157	/	/
CHA61/F	X	/	/	290	309	334	372	400
	Y	/	/	158	173	173	191	211
	Z	/	/	137	157	157	230	230

3.1.4 IHA.1

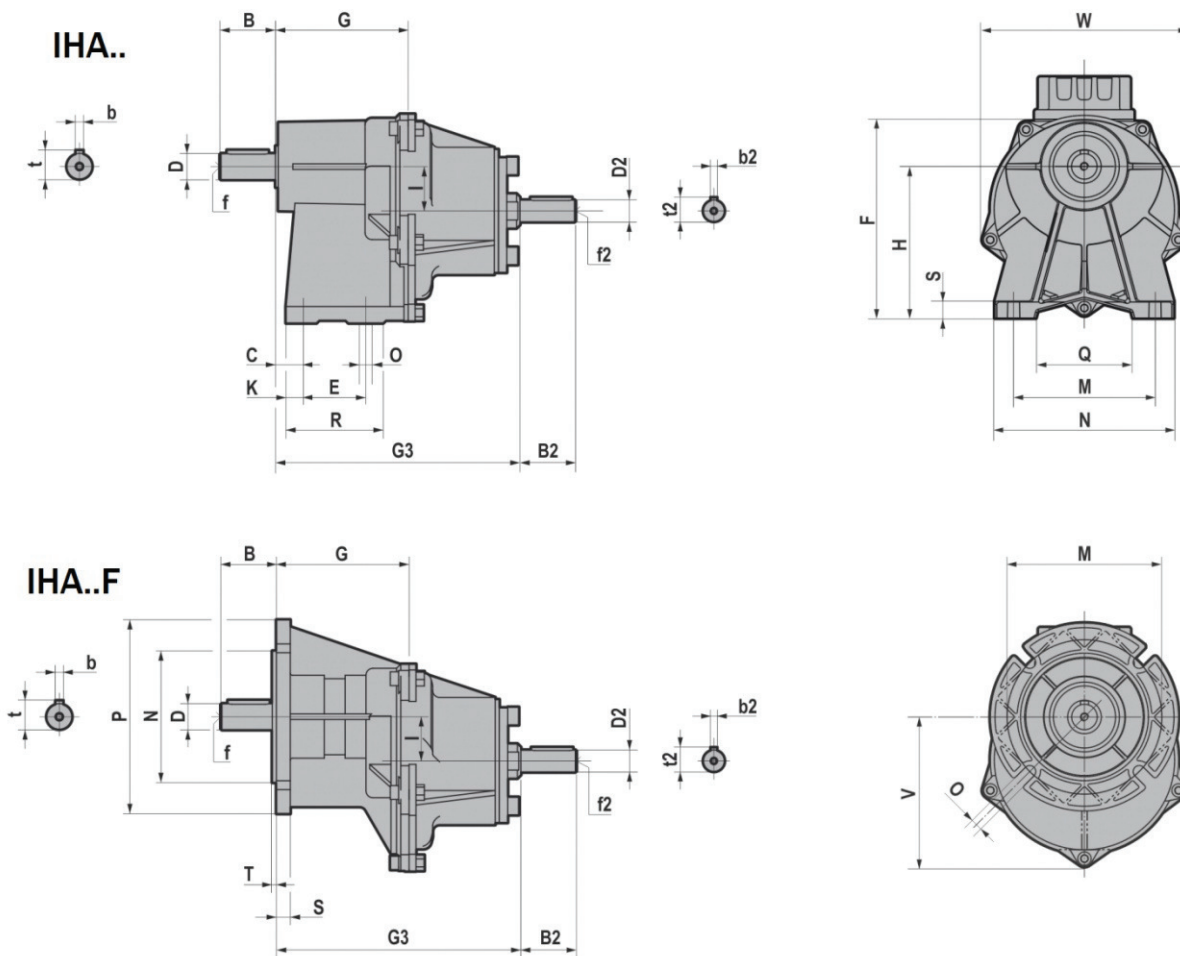

	D j6	B	C	E	F	G	H	I	K	M	N	O	Q	R	S	W	b	t	f
IHA41/F	16																5	18	M6
	19	40	20	45	151	95,5	113	32	12,5	105	130	9	75	70	12	152	6	21,5	M6
IHA51/F	24	50	6	70	169	104	130	32	15	150	180	11	115	100	12	152	8	27	M8
IHA61/F	28	60															8	31	M8
	24	50	7,5	70	219,5	129	165	47,5	20	165	200	11	120	110	15	218	8	27	M8

	M	N f8	O	P	S	T	V
IHA41F	115	95	9 (n.4)	140	10	3	111,5
IHA51F	130	110	9 (n.4)	160	10	3,5	111,5
IHA61F	165	130	11 (n.4)	200	15	3,5	161,5

	G3	D2 j6	B2	b2	f2	t2
IHA41/F	176	16	40	5	M6	18
IHA51/F	184,5	16	40	5	M6	18
IHA61/F	209	19	40	6	M6	21,5

3.1.5 HA.2

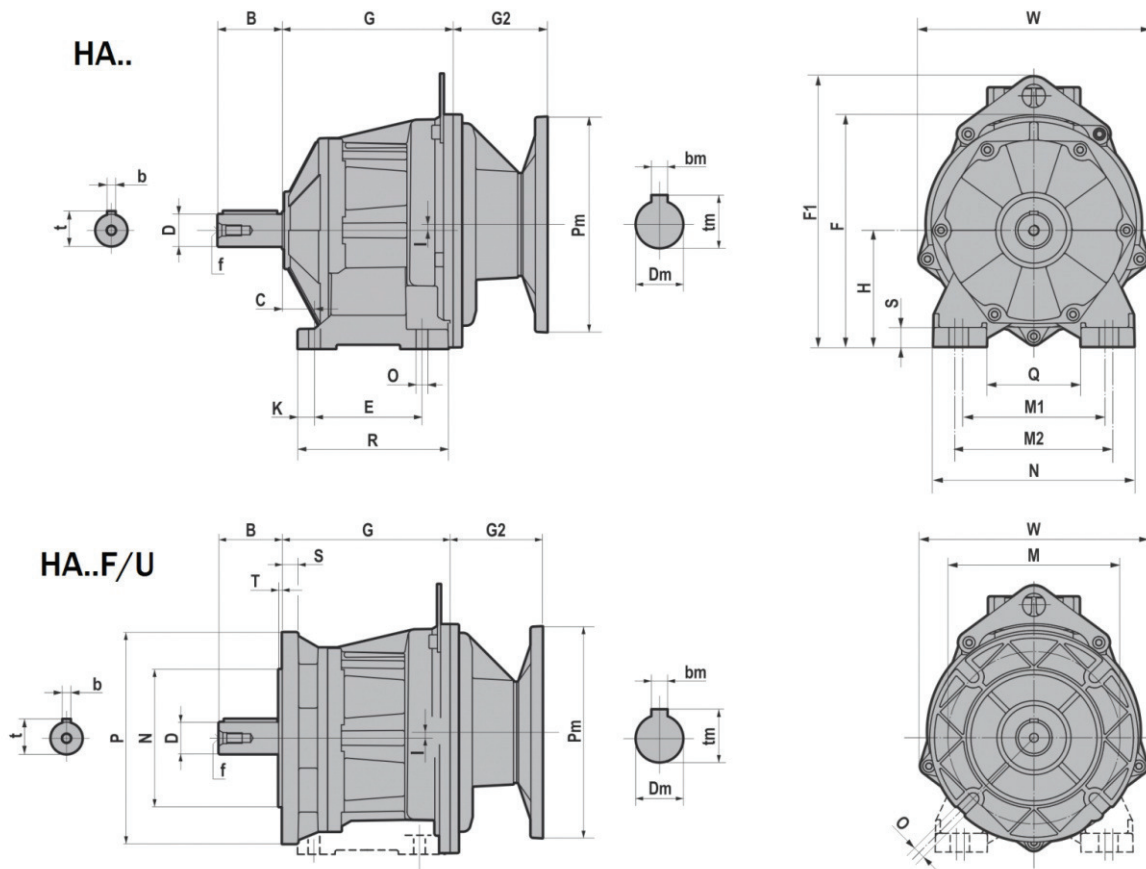

HA../F/U	D j6	B	b	t	f	C	E	F	F1	G	H	I	K	M1	M2	N	O	Q	R	S	W
HA32	20	40	6	22,5	M6	18	80	155	/	117,5	75	10	13	110	120	145	9	75	111	15	152
	19	40	6	21,5	M6																
	16	40	5	18	M6																
	14	30	5	16	M6																
HA42	25	50	8	28	M10	25	85	160	/	124,5	80	10	13	110	120	145	9	75	111	15	152
	28	60	8	31	M10																
	24	50	8	27	M8																
	22	50	6	24,5	M8																
	20	40	6	22,5	M6																
HA52	19	40	6	21,5	M6	30	100	217,5	255,5	159	110	5,5	15,5	135	150	190	11	90	140	18	218
	30	60	8	33	M10																
	35	70	10	38	M12																
	32	60	10	35	M10																
	28	60	8	31	M10																
	25	50	8	28	M10																
HA62	24	50	8	27	M8	35	110	237,5	275,5	168	120	15,5	20	170	185	230	14	120	150	20	218
	40	80	12	43	M16																
	35 k6	70	10	38	M12																
	30	60	8	33	M10																
	28	60	8	31	M10																

3.1 REDUCERS/GEARED MOTORS

	P	M	N f8	O	G	I	S	T	W
HA32F/U	140	115	95	9 (n.4)	117,5	10	10	3	152
	120	100	80						
HA42F/U	160	130	110	9 (n.4)	124,5	10	10	3,5	152
	140	115	95						
HA52F/U	200	165	130	11 (n.4)	159	5,5	15	3,5	218
	160	130	110						
HA62F/U	250	215	180	14 (n.4)	168	15,5	15	4	218
	200	165	130						

IEC	Pm x Dm	Pm x Dm	G2	
			HA32F/U - HA42F/U	HA52F/U - HA62F/U
063	140X11	090x11	55,0	/
071	160X14	105x14	55,0	/
080	200X19	120x19	86,0	87,5
090	200X24	140x24	86,0	87,5
100-112	250X28	160x28	/	87,5

B5	Pm	Dm	bm	tm
063	140	11	4	12,8
071	160	14	5	16,3
080	200	19	6	21,8
090	200	24	8	27,3
100	250	28	8	31,3
112	250	28	8	31,3

B14	Pm	Dm	bm	tm
071	105	14	5	16,3
080	120	19	6	21,8
090	140	24	8	27,3
100	160	28	8	31,3
112	160	28	8	31,3

3.1.6 CHA.2

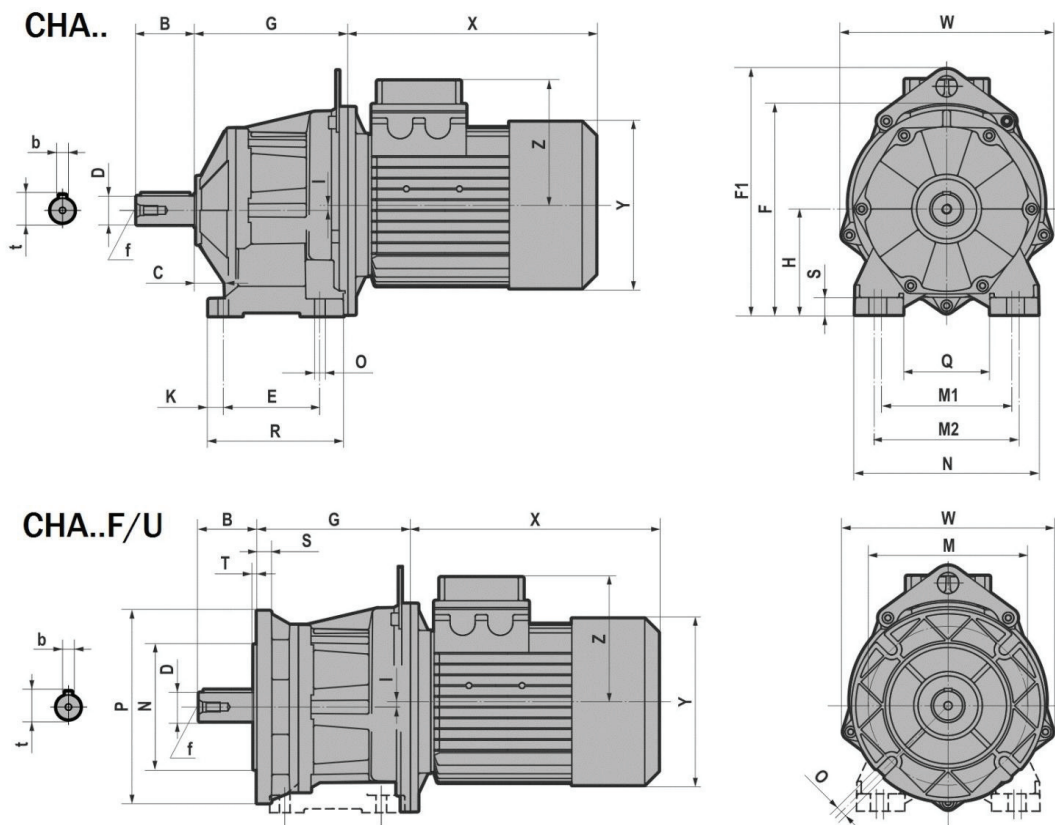

CHA../F/U	D j6	B	b	t	f	C	E	F	F1	G	H	I	K	M1	M2	N	O	Q	R	S	W	
CHA32	20	40	6	22,5	M6	18	80	155	/	117,5	75	10	13	110	120	145	9	75	111	15	152	
	19	40	6	21,5	M6																	
	16	40	5	18	M6																	
	14	30	5	16	M6																	
CHA42	25	50	8	28	M10	25	85	160	/	124,5	80	10	13	110	120	145	9	75	111	15	152	
	28	60	8	31	M10																	
	24	50	8	27	M8																	
	22	50	6	24,5	M8																	
	20	40	6	22,5	M6																	
CHA52	19	40	6	21,5	M6	30	100	217,5	255,5	159	110	5,5	15,5	135	150	190	11	90	140	18	218	
	30	60	8	33	M10																	
	35	70	10	38	M12																	
	32	60	10	35	M10																	
	28	60	8	31	M10																	
CHA62	25	50	8	28	M10	35	110	237,5	275,5	168	120	15,5	20	170	185	230	14	120	150	20	218	
	24	50	8	27	M8																	
	40	80	12	43	M16																	
	35 k6	70	10	38	M12																	
	30	60	8	33	M10																	
	28	60	8	31	M10																	

3.1 REDUCERS/GEARED MOTORS

	P	M	N f8	O	G	I	S	T	W
CHA32F/U	140	115	95	9 (n.4)	117,5	10	10	3	152
	120	100	80						
CHA42F/U	160	130	110	9 (n.4)	124,5	10	10	3,5	152
	140	115	95						
CHA52F/U	200	165	130	11 (n.4)	159	5,5	15	3,5	218
	160	130	110						
CHA62F/U	250	215	180	14 (n.4)	168	15,5	15	4	218
	200	165	130						

		T (IE1 - IE2)						
CHA..F/U		063	071	080	090S	090L	100	112
CHA32 CHA42	X	180	205	223	232	257	/	/
	Y	121	139	158	173	173	/	/
	Z	104	112	122	130	130	/	/
CHA52 CHA62	X	/	/	218	232	257	290	302
	Y	/	/	158	173	173	191	211
	Z	/	/	122	130	130	139	154

		TB (IE1 - IE2)						
CHA..F/U		063	071	080	090S	090L	100	112
CHA32 CHA42	X	238	271	294	309	334	/	/
	Y	121	139	158	173	173	/	/
	Z	119	129	137	157	157	/	/
CHA52 CHA62	X	/	/	290	309	334	372	400
	Y	/	/	158	173	173	191	211
	Z	/	/	137	157	157	230	230

3.1.7 IHA.2

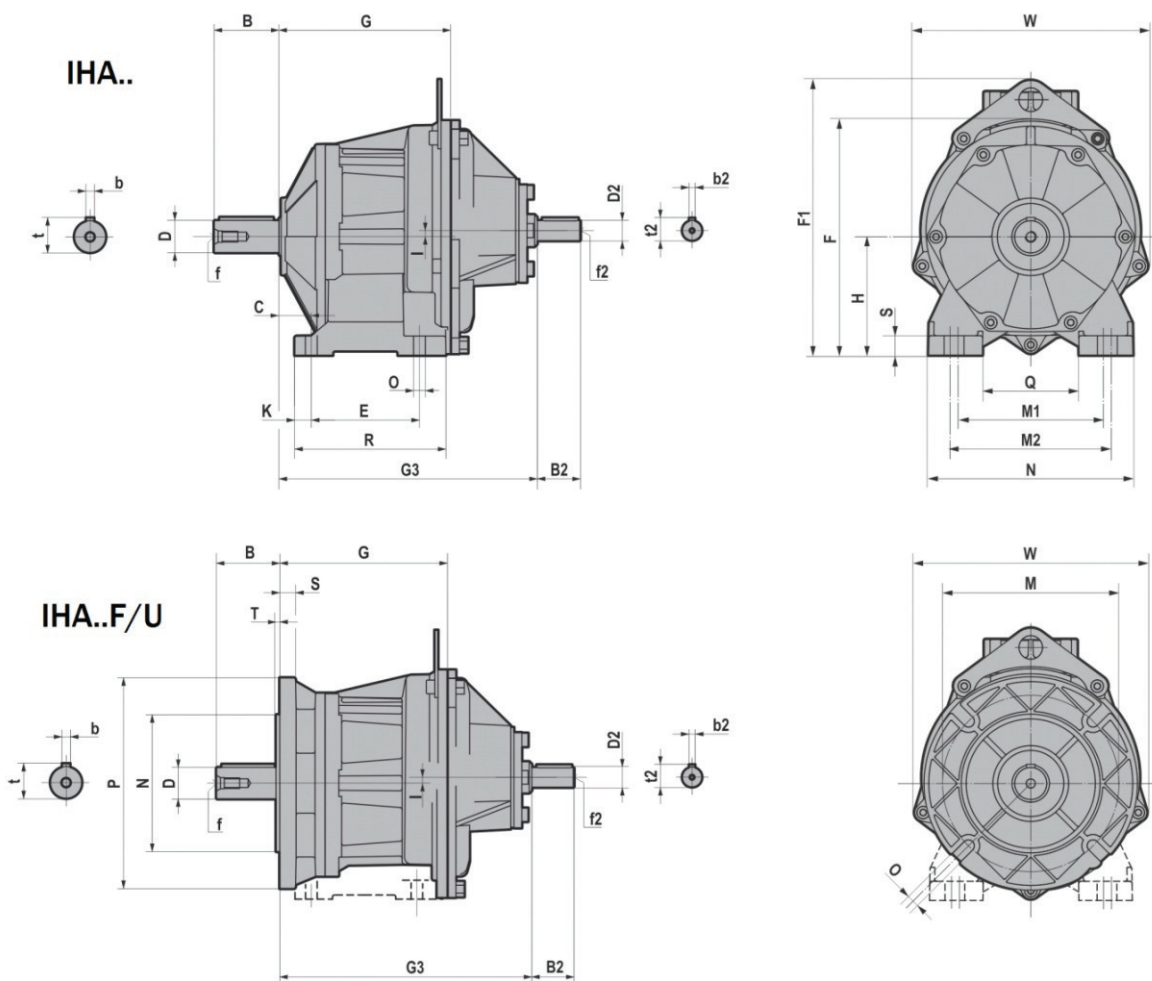

IHA../F/U	Dj6	B	b	t	f	C	E	F	F1	G	H	I	K	M1	M2	N	O	Q	R	S	W
IHA32	20	40	6	22,5	M6	18	80	155	/	117,5	75	10	13	110	120	145	9	75	111	15	152
	19	40	6	21,5	M6																
	16	40	5	18	M6																
	14	30	5	16	M6																
IHA42	25	50	8	28	M10	25	85	160	/	124,5	80	10	13	110	120	145	9	75	111	15	152
	28	60	8	31	M10																
	24	50	8	27	M8																
	22	50	6	24,5	M8																
	20	40	6	22,5	M6																
IHA52	19	40	6	21,5	M6	30	100	217,5	255,5	159	110	5,5	15,5	135	150	190	11	90	140	18	218
	30	60	8	33	M10																
	35	70	10	38	M12																
	32	60	10	35	M10																
	28	60	8	31	M10																
	25	50	8	28	M10																
IHA62	24	50	8	27	M8	35	110	237,5	275,5	168	120	15,5	20	170	185	230	14	120	150	20	218
	40	80	12	43	M16																
	35 k6	70	10	38	M12																
	30	60	8	33	M10																
	28	60	8	31	M10																

3.1 REDUCERS/GEARED MOTORS

	P	M	N f8	O	G	I	S	T	W
IHA32F/U	140	115	95	9 (n.4)	117,5	10	10	3	152
	120	100	80						
IHA42F/U	160	130	110	9 (n.4)	124,5	10	10	3,5	152
	140	115	95						
IHA52F/U	200	165	130	11 (n.4)	159	5,5	15	3,5	218
	160	130	110						
IHA62F/U	250	215	180	14 (n.4)	168	15,5	15	4	218
	200	165	130						

	G3	D2 j6	B2	b2	f2	t2
IHA32/F/U	198	16	40	5	M6	18
IHA42/F/U	205	16	40	5	M6	18
IHA52/F/U	239	19	40	6	M6	21,5
IHA62/F/U	248	19	40	6	M6	21,5

3.1.8 HA.3

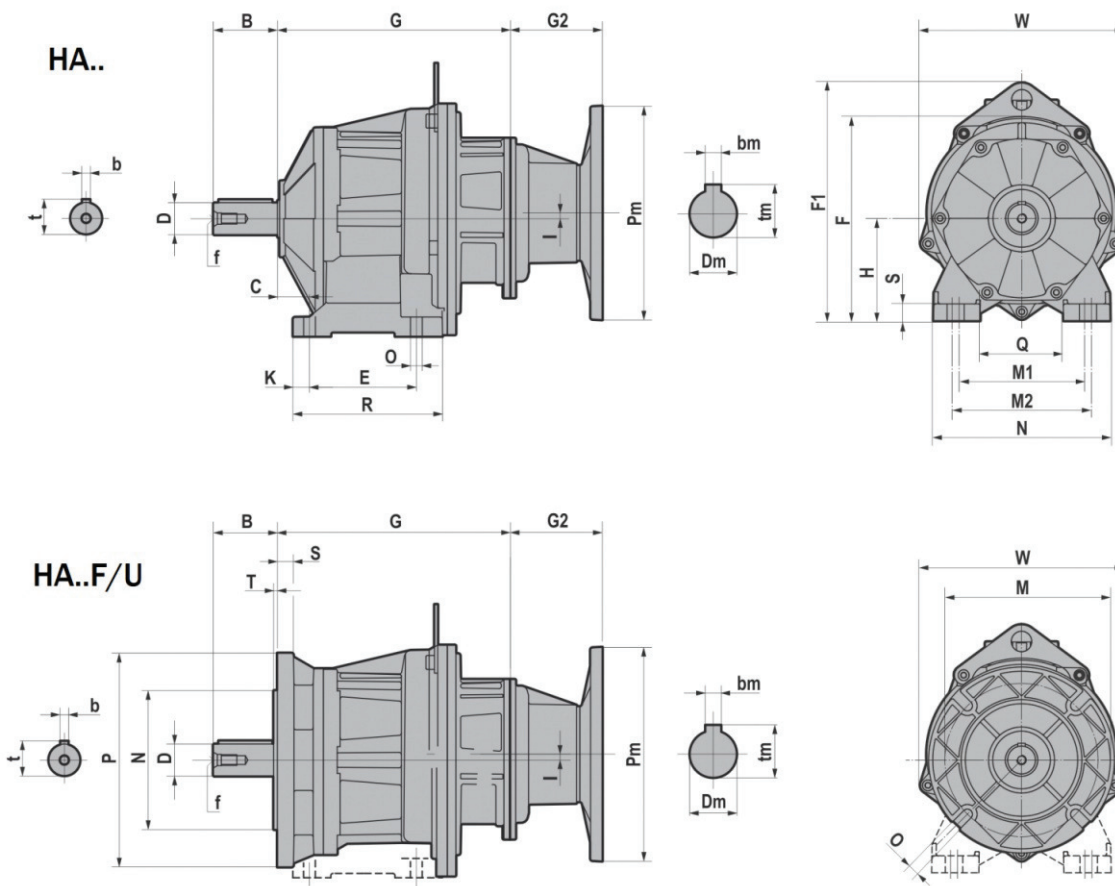

HA..F/U	D j6	B	b	t	f	C	E	F	F1	G	H	I	K	M1	M2	N	O	Q	R	S	W
HA33	20	40	6	22,5	M6	18	80	155	/	117,5	75	10	13	110	120	145	9	75	111	15	152
	19	40	6	21,5	M6																
	16	40	5	18	M6																
	14	30	5	16	M6																
HA43	25	50	8	28	M10	25	85	160	/	124,5	80	10	13	110	120	145	9	75	111	15	152
	28	60	8	31	M10																
	24	50	8	27	M8																
	22	50	6	24,5	M8																
	20	40	6	22,5	M6																
HA53	19	40	6	21,5	M6	30	100	217,5	255,5	159	110	5,5	15,5	135	150	190	11	90	140	18	218
	30	60	8	33	M10																
	35	70	10	38	M12																
	32	60	10	35	M10																
	28	60	8	31	M10																
	25	50	8	28	M10																
HA63	24	50	8	27	M8	35	110	237,5	275,5	168	120	15,5	20	170	185	230	14	120	150	20	218
	40	80	12	43	M16																
	35 k6	70	10	38	M12																
	30	60	8	33	M10																
	28	60	8	31	M10																

3.1 REDUCERS/GEARED MOTORS

	P	M	N f8	O	G	I	S	T	W
HA33F/U	140	115	95	9 (n.4)	117,5	10	10	3	152
	120	100	80						
HA43F/U	160	130	110	9 (n.4)	124,5	10	10	3,5	152
	140	115	95						
HA53F/U	200	165	130	11 (n.4)	159	5,5	15	3,5	218
	160	130	110						
HA63F/U	250	215	180	14 (n.4)	168	15,5	15	4	218
	200	165	130						

			G2
IEC	Pm x Dm	Pm x Dm	HA33/F/U - HA43/F/U - HA53/F/U - HA63/F/U
063	140X11	090x11	55
071	160X14	105x14	55
080	200X19	120x19	86
090	200X24	140x24	86

B5	Pm	Dm	bm	tm
063	140	11	4	12,8
071	160	14	5	16,3
080	200	19	6	21,8
090	200	24	8	27,3

B14	Pm	Dm	bm	tm
071	105	14	5	16,3
080	120	19	6	21,8
090	140	24	8	27,3

3.1.9 CHA.3

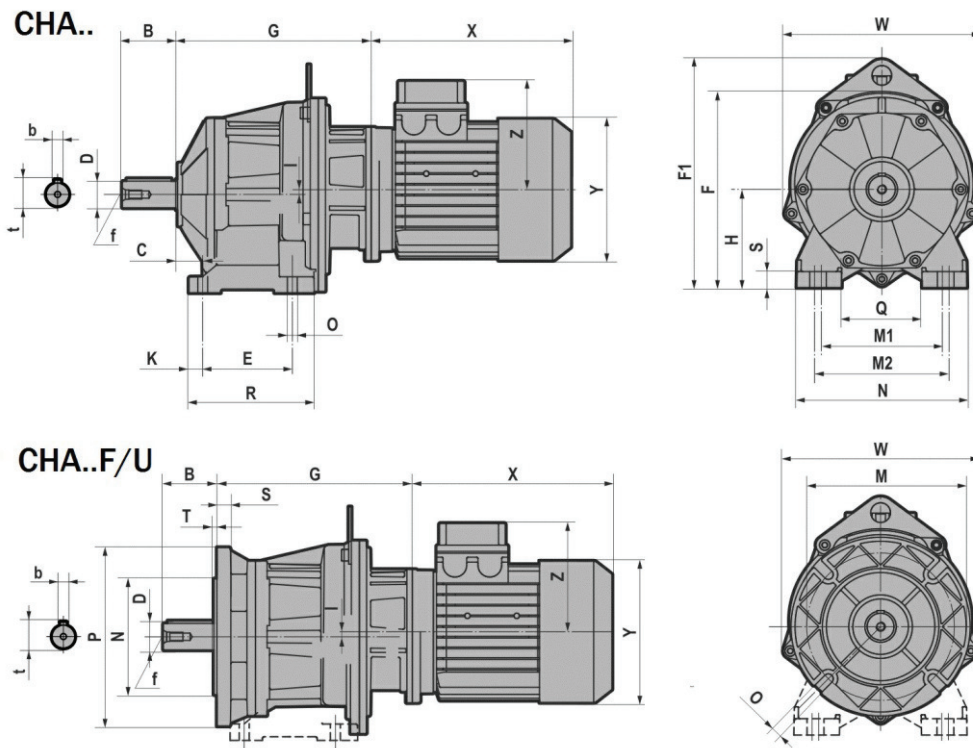

CHA..F/U	D j6	B	b	t	f	C	E	F	F1	G	H	I	K	M1	M2	N	O	Q	R	S	W
CHA33	20	40	6	22,5	M6	18	80	155	/	117,5	75	10	13	110	120	145	9	75	111	15	152
	19	40	6	21,5	M6																
	16	40	5	18	M6																
	14	30	5	16	M6																
CHA43	25	50	8	28	M10	25	85	160	/	124,5	80	10	13	110	120	145	9	75	111	15	152
	28	60	8	31	M10																
	24	50	8	27	M8																
	22	50	6	24,5	M8																
	20	40	6	22,5	M6																
CHA53	19	40	6	21,5	M6	30	100	217,5	255,5	159	110	5,5	15,5	135	150	190	11	90	140	18	218
	30	60	8	33	M10																
	35	70	10	38	M12																
	32	60	10	35	M10																
	28	60	8	31	M10																
	25	50	8	28	M10																
CHA63	24	50	8	27	M8	35	110	237,5	275,5	168	120	15,5	20	170	185	230	14	120	150	20	218
	40	80	12	43	M16																
	35 k6	70	10	38	M12																
	30	60	8	33	M10																
	28	60	8	31	M10																

3.1 REDUCERS/GEARED MOTORS

	P	M	N f8	O	G	I	S	T	W
CHA33F/U	140	115	95	9 (n.4)	117,5	10	10	3	152
	120	100	80						
CHA43F/U	160	130	110	9 (n.4)	124,5	10	10	3,5	152
	140	115	95						
CHA53F/U	200	165	130	11 (n.4)	159	5,5	15	3,5	218
	160	130	110						
CHA63F/U	250	215	180	14 (n.4)	168	15,5	15	4	218
	200	165	130						

T (IE1 - IE2)						
CHA..F/U		063	071	080	090S	090L
CHA33 CHA43 CHA53 CHA63	X	180	205	223	232	257
	Y	121	139	158	173	173
	Z	104	112	122	130	130

TB (IE1 - IE2)						
CHA..F/U		063	071	080	090S	090L
CHA33 CHA43 CHA53 CHA63	X	238	271	294	309	334
	Y	121	139	158	173	173
	Z	119	129	137	157	157

3.1.10 IHA.3

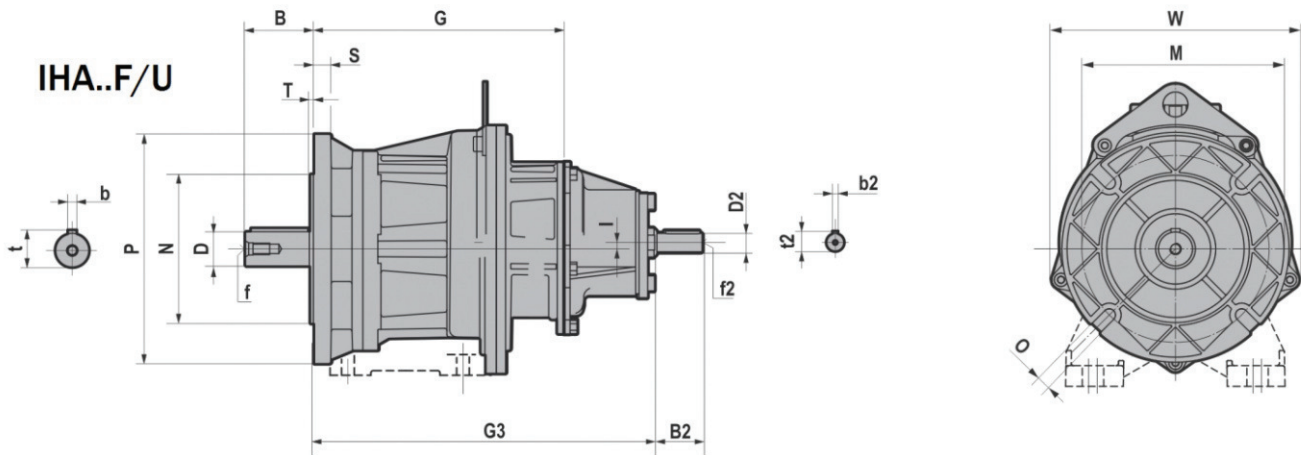
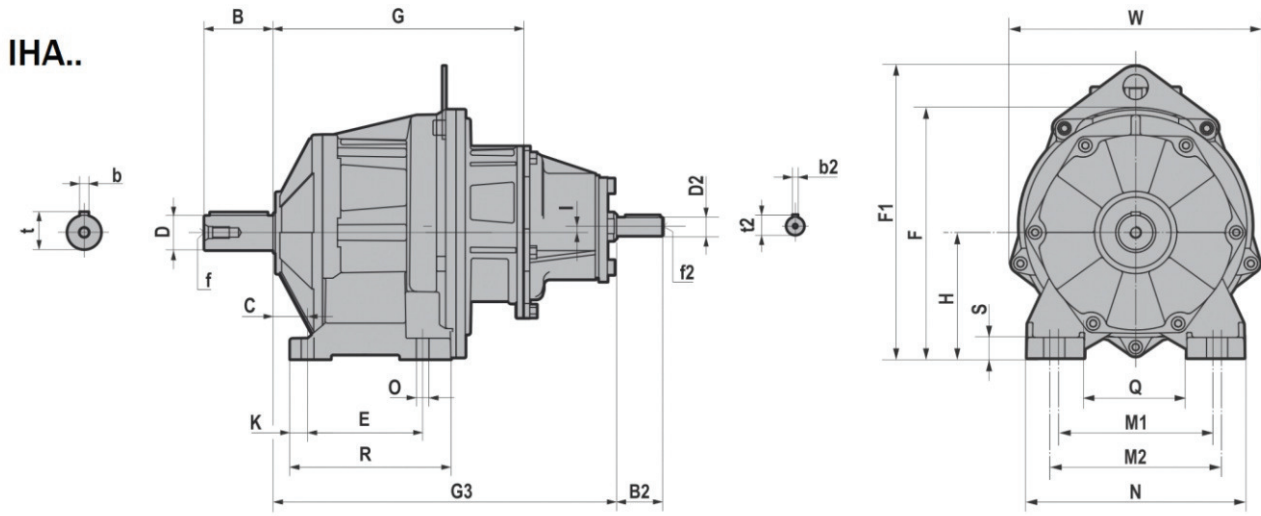

3.1 REDUCERS/GEARED MOTORS

IHA..F/U	D j6	B	b	t	f	C	E	F	F1	G	H	I	K	M1	M2	N	O	Q	R	S	W
IHA33	20	40	6	22,5	M6	18	80	155	/	117,5	75	10	13	110	120	145	9	75	111	15	152
	19	40	6	21,5	M6																
	16	40	5	18	M6																
	14	30	5	16	M6																
IHA43	25	50	8	28	M10	25	85	160	/	124,5	80	10	13	110	120	145	9	75	111	15	152
	28	60	8	31	M10																
	24	50	8	27	M8																
	22	50	6	24,5	M8																
	20	40	6	22,5	M6																
IHA53	19	40	6	21,5	M6	30	100	217,5	255,5	159	110	5,5	15,5	135	150	190	11	90	140	18	218
	30	60	8	33	M10																
	35	70	10	38	M12																
	32	60	10	35	M10																
	28	60	8	31	M10																
	25	50	8	28	M10																
IHA63	24	50	8	27	M8	35	110	237,5	275,5	168	120	15,5	20	170	185	230	14	120	150	20	218
	40	80	12	43	M16																
	35 k6	70	10	38	M12																
	30	60	8	33	M10																
	28	60	8	31	M10																

	P	M	N f8	O	G	I	S	T	W
IHA33F/U	140	115	95	9 (n.4)	117,5	10	10	3	152
	120	100	80						
IHA43F/U	160	130	110	9 (n.4)	124,5	10	10	3,5	152
	140	115	95						
IHA53F/U	200	165	130	11 (n.4)	159	5,5	15	3,5	218
	160	130	110						
IHA63F/U	250	215	180	14 (n.4)	168	15,5	15	4	218
	200	165	130						

	G3	D2 j6	B2	b2	f2	t2
IHA33	251	16	40	5	M6	18
IHA43	258	16	40	5	M6	18
IHA53	299	16	40	5	M6	18
IHA63	308	16	40	5	M6	18

3.1.11 HR.1

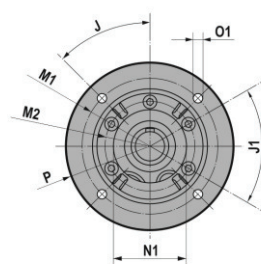
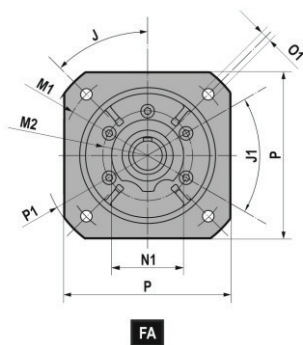
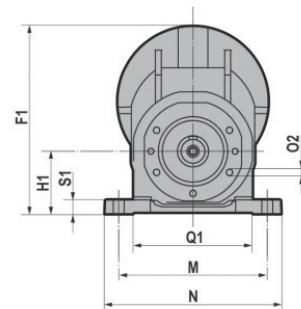
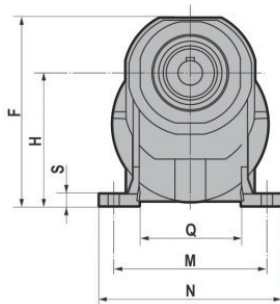
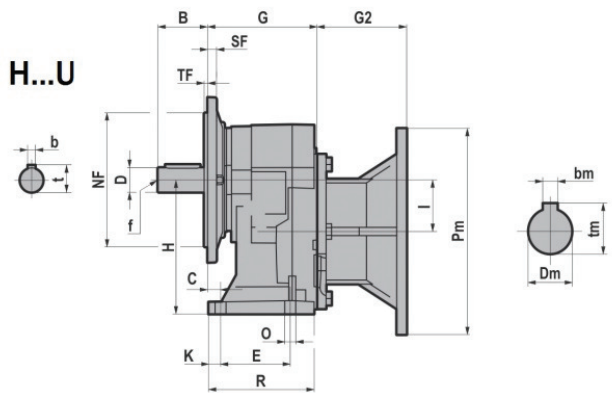
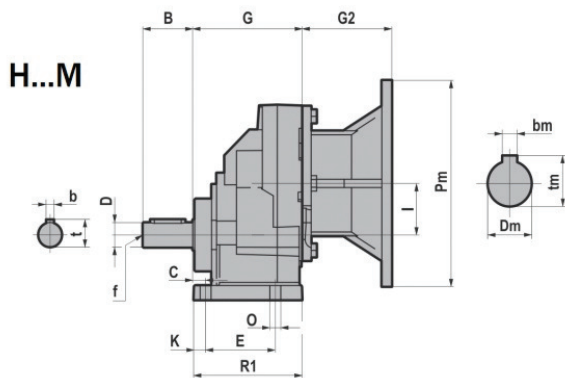
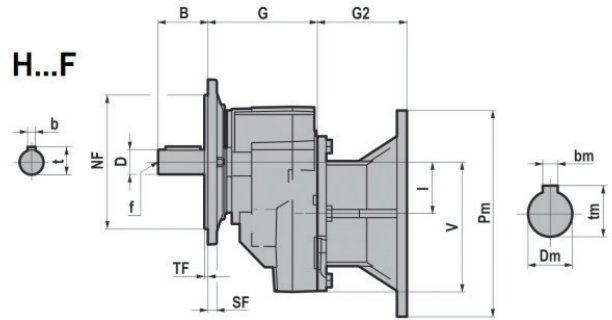
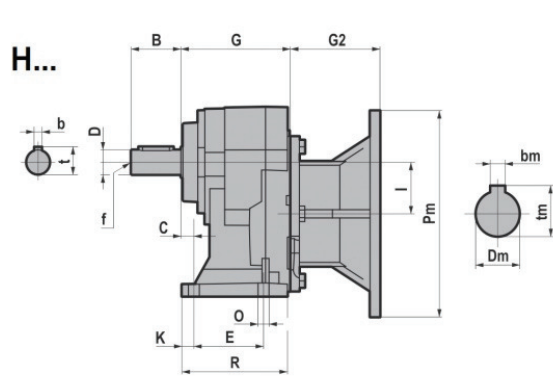

FA

FB

FC

FD

3.1 REDUCERS/GEARED MOTORS

HR.../F/U/M	D	B	C	E	F	F1	G	H	H1	I	K	M	N	O	O2	Q	Q1	R	R1	S	S1	-V	b	t	f
HR041	19 j6	40	13	45	168,5	168	100	120	50	42	12	105	130 125 (O41M)	9	M8x17 (n.5)	74	55	86,5	98	9,5	8	118	6	21,5	M6
HR051	24 j6	50	13	70	183,5	189	110	130	63	50	12	150	178	11	M8x17 (n.5)	100	121,5	106	109	11,5	14	126	8	27	M8
HR061	28 j6	60	16	70	231	216	125	165	80	60	14	165	195	11	M8x17 (n.5)	110	135,5	120	123	15	16	136	8	31	M10
HR081	38 k6	80	25	85	277	284	135	195	100	80	23	185	230 232 (O81M)	14	M10x20 (n.7)	123	151	130	135	15	20	184	10	41	M12
HR101	48 k6	110	19	130	355	377	180	252	125	100	17	240	295	18	M10x20 (n.6)	162	185,5	173	178	16	22	251,5	14	51,5	M16
HR121	55 m6	110	25	150	422	426,5	210	300	160	115	22	280	340	18	M12x25 (n.7)	183	224	202	207	19	25	266,5	16	59	M20

		J	J1	M1	M2	NF f8	N1	O1	P	P1	SF	TF
HR041F/U HR051F/U	FA	45°	45°	Ø165	Ø85	130	70	11 (n.4)	160	Ø200	9	3,5
	FB			Ø130	Ø85	110		9 (n.4)	Ø160	/	9	3,5
	FC			Ø115	Ø85	95		9 (n.4)	Ø140	/	9	3
	FD			Ø100	Ø85	80		M8 (n.4)	Ø120	/	9	3
HR061F/U	FA	45°	45°	Ø215	Ø105	180	90	14 (n.4)	200	Ø250	12	4
	FB			Ø165	Ø105	130		11 (n.4)	Ø200	/	12	3,5
HR081F/U HR101F/U	FA	45°	45°	Ø265	Ø130	230	110	14 (n.4)	250	Ø300	15	4
	FB			Ø215	Ø130	180		14 (n.4)	Ø250	/	15	4
	FC			Ø165	Ø130	130		11 (n.4)	Ø200	/	15	3,5
HR121F/U	FA	45°	45°	Ø300	Ø165	250	130	18 (n.4)	300	Ø350	16	5
	FB			Ø265	Ø165	230		14 (n.4)	Ø300	/	16	4
	FC			Ø 215	Ø165	180		14 (n.4)	Ø250	/	16	4

		G2					
IEC	Pm x Dm	HR041F/U/M	HR051F/U/M	HR061F/U/M	HR081F/U/M	HR101F/U/M	HR121F/U/M
071	160x14	69,0	69,0	/	/	/	/
080	200x19	90,0	90,0	90,0	70,0	/	/
090	200x24	90,0	90,0	90,0	70,0	/	/
100-112	250x28	/	105,0	105,0	85,0	75,5	/
132	300x38	/	/	/	110,0	100,5	100,5
160	350x42	/	/	/	/	148,0	148,0
180	350x48	/	/	/	/	148,0	148,0
200	400x55	/	/	/	/	/	185,0

B5	Pm	Dm	bm	tm
071	160	14	5	16,3
080	200	19	6	21,8
090	200	24	8	27,3
100	250	28	8	31,3
112	250	28	8	31,3
132	300	38	10	41,3
160	350	42	12	45,3
180	350	48	14	51,8
200	400	55	16	59,3

3.1.12 CHR..1

CH...

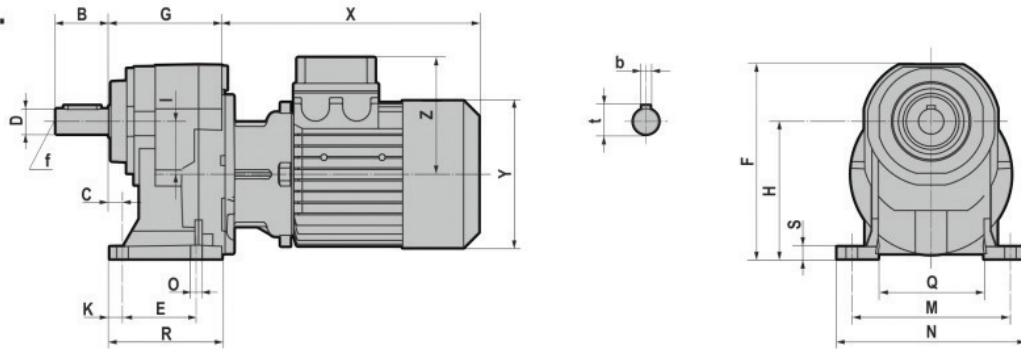

CH...M

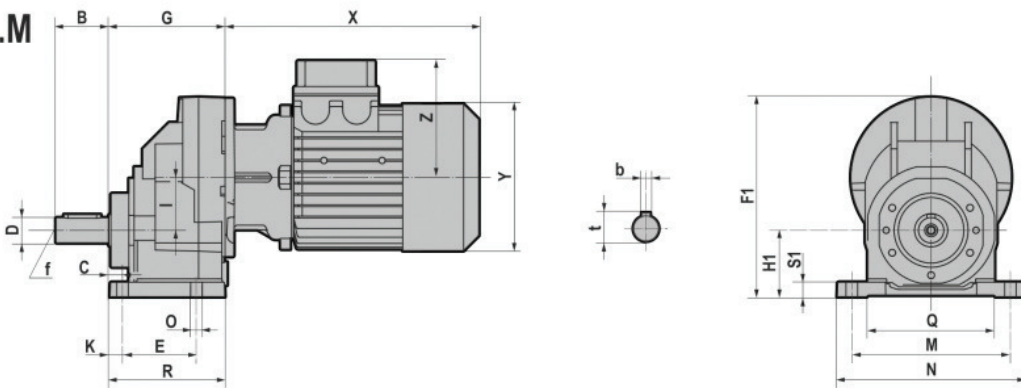

CH...F

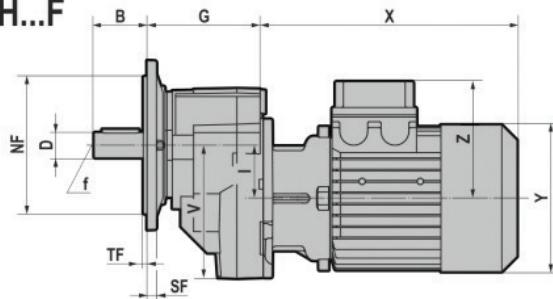

CH...U

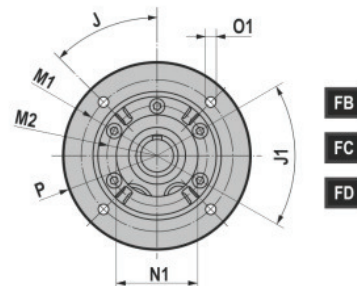
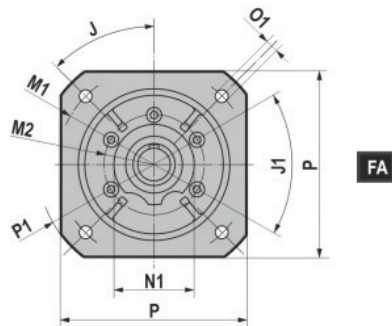
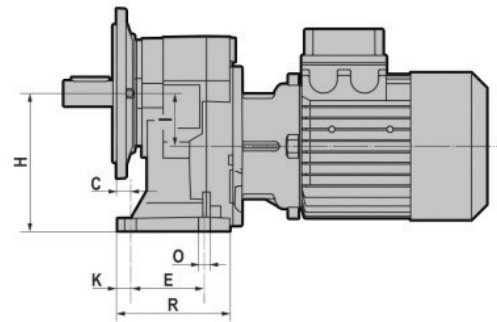

3.1 REDUCERS/GEARED MOTORS

CHR.../F/U/M	D	B	C	E	F	F1	G	H	H1	I	K	M	N	O	O2	Q	Q1	R	R1	S	S1	-V	b	t	f
CHR041	19 j6	40	13	45	168,5	168	100	120	50	42	12	105	130 125 (041M)	9	M8x17 (n.5)	74	55	86,5	98	9,5	8	118	6	21,5	M6
CHR051	24 j6	50	13	70	183,5	189	110	130	63	50	12	150	178	11	M8x17 (n.5)	100	121,5	106	109	11,5	14	126	8	27	M8
CHR061	28 j6	60	16	70	231	216	125	165	80	60	14	165	195	11	M8x17 (n.5)	110	135,5	120	123	15	16	136	8	31	M10
CHR081	38 k6	80	25	85	277	284	135	195	100	80	23	185	230 232 (081M)	14	M10x20 (n.5)	123	151	130	135	15	20	184	10	41	M12
CHR101	48 k6	110	19	130	355	377	180	252	125	100	17	240	295	18	M10x20 (n.6)	162	185,5	173	178	16	22	251,5	14	51,5	M16
CHR121	55 m6	110	25	150	422	426,5	210	300	160	115	22	280	340	18	M12x25 (n.7)	183	224	202	207	19	25	266,5	16	59	M20

		J	J1	M1	M2	NF f8	N1	O1	P	P1	SF	TF
CHR041F/U CHR051F/U	FA	45°	45°	Ø165	Ø85	130	70	11 (n.4)	160	Ø200	9	3,5
	FB			Ø130	Ø85	110		9 (n.4)	Ø160	/	9	3,5
	FC			Ø115	Ø85	95		9 (n.4)	Ø140	/	9	3
	FD			Ø100	Ø85	80		M8 (n.4)	Ø120	/	9	3
CHR061F/U	FA	45°	45°	Ø215	Ø105	180	90	14 (n.4)	200	Ø250	12	4
	FB			Ø165	Ø105	130		11 (n.4)	Ø200	/	12	3,5
CHR081F/U CHR101F/U	FA	45°	45°	Ø265	Ø130	230	110	14 (n.4)	250	Ø300	15	4
	FB			Ø215	Ø130	180		14 (n.4)	Ø250	/	15	4
	FC			Ø165	Ø130	130		11 (n.4)	Ø200	/	15	3,5
CHR121F/U	FA	45°	45°	Ø300	Ø165	250	130	18 (n.4)	300	Ø350	16	5
	FB			Ø265	Ø165	230		14 (n.4)	Ø300	/	16	4
	FC			Ø215	Ø165	180		14 (n.4)	Ø250	/	16	4

		T (IE1 - IE2)									
CHR.../F/U/M		063	071	080	090S	090L	100	112	132S	132M/L	
CHR041 CHR051 CHR061	X	215	241	268	296	321	333	351	/	/	
	Y	121	139	158	173	173	191	211	/	/	
	Z	104	112	122	130	130	139	154	/	/	
CHR081	X	/	221	248	276	301	335	356	405	443	
	Y	/	139	158	173	173	191	211	249	249	
	Z	/	112	122	130	130	139	154	194	194	
CHR101 CHR121	X	/	/	/	267	292	326	347	396	434	
	Y	/	/	/	173	173	191	211	249	249	
	Z	/	/	/	130	130	139	154	194	194	

		TB (IE1 - IE2)									
CHR.../F/U/M		063	071	080	090S	090L	100	112	132S	132M/L	
CHR041 CHR051 CHR061	X	273	306.5	341	373	398	415	448	/	/	
	Y	121	139	158	173	173	191	211	/	/	
	Z	119	129	137	157	157	168	183	/	/	
CHR081	X	/	286.5	321	353	378	417	453	505	547	
	Y	/	139	158	173	173	191	211	249	249	
	Z	/	129	137	157	157	168	183	230	230	
CHR101 CHR121	X	/	/	/	343	368	407	443	495	537	
	Y	/	/	/	173	173	191	211	249	249	
	Z	/	/	/	157	157	168	183	230	230	

3.1.13 IHR..1

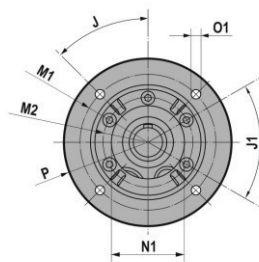
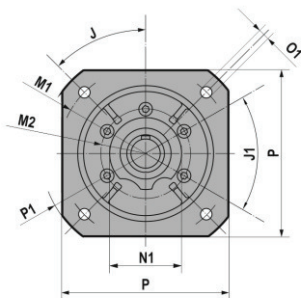
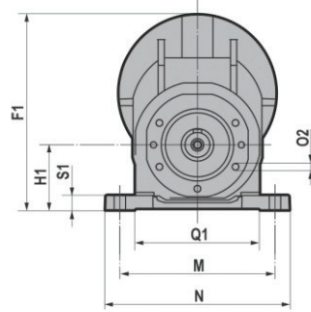
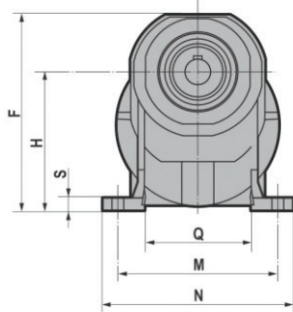
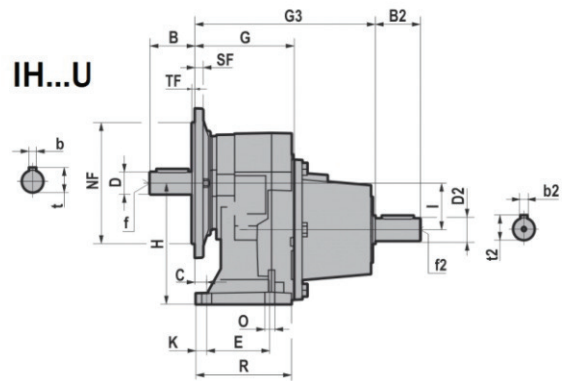
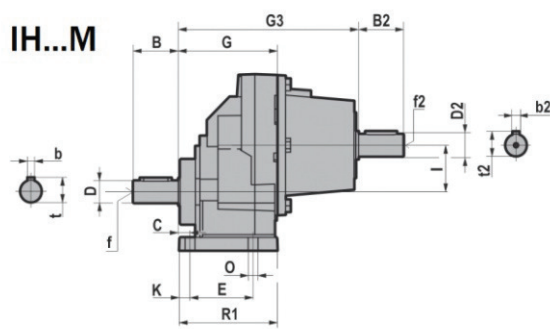
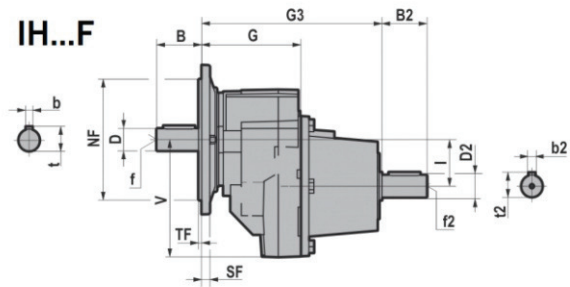
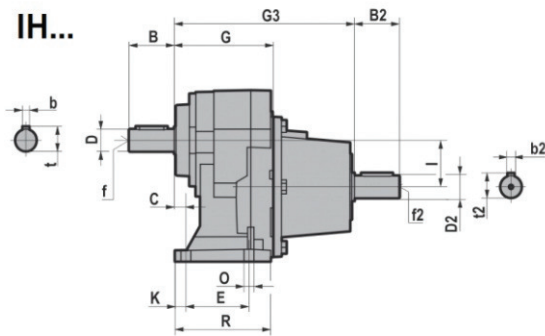

FA

FB

FC

FD

3.1 REDUCERS/GEARED MOTORS

IHR.../F/U/M	D	B	C	E	F	F1	G	H	H1	I	K	M	N	O	O2	Q	Q1	R	R1	S	S1	-V	b	t	f
IHR041	19 j6	40	13	45	168,5	168	100	120	50	42	12	105	130 125 (041M)	9	M8x17 (n.5)	74	55	86,5	98	9,5	8	118	6	21,5	M6
IHR051	24 j6	50	13	70	183,5	189	110	130	63	50	12	150	178	11	M8x17 (n.5)	100	121,5	106	109	11,5	14	126	8	27	M8
IHR061	28 j6	60	16	70	231	216	125	165	80	60	14	165	195	11	M8x17 (n.5)	110	135,5	120	123	15	16	136	8	31	M10
IHR081	38 k6	80	25	85	277	284	135	195	100	80	23	185	230 232 (081M)	14	M10x20 (n.7)	123	151	130	135	15	20	184	10	41	M12
IHR101	48 k6	110	19	130	355	377	180	252	125	100	17	240	295	18	M10x20 (n.6)	162	185,5	173	178	16	22	251,5	14	51,5	M16
IHR121	55 m6	110	25	150	422	426,5	210	300	160	115	22	280	340	18	M12x25 (n.7)	183	224	202	207	19	25	266,5	16	59	M20

		J	J1	M1	M2	NF f8	N1	O1	P	P1	SF	TF
IHR041F/U IHR051F/U	FA	45°	45°	Ø165	Ø85	130	70	11 (n.4)	160	Ø200	9	3,5
	FB			Ø130	Ø85	110		9 (n.4)	Ø160	/	9	3,5
	FC			Ø115	Ø85	95		9 (n.4)	Ø140	/	9	3
	FD			Ø100	Ø85	80		M8 (n.4)	Ø120	/	9	3
IHR061F/U	FA	45°	45°	Ø215	Ø105	180	90	14 (n.4)	200	Ø250	12	4
	FB			Ø165	Ø105	130		11 (n.4)	Ø200	/	12	3,5
IHR081F/U IHR101F/U	FA	45°	45°	Ø265	Ø130	230	110	14 (n.4)	250	Ø300	15	4
	FB			Ø215	Ø130	180		14 (n.4)	Ø250	/	15	4
	FC			Ø165	Ø130	130		11 (n.4)	Ø200	/	15	3,5
IHR121F/U	FA	45°	45°	Ø300	Ø165	250	130	18 (n.4)	300	Ø350	16	5
	FB			Ø265	Ø165	230		14 (n.4)	Ø300	/	16	4
	FC			Ø215	Ø165	180		14 (n.4)	Ø250	/	16	4

	G3	B2	D2	b2	t2	f2
IHR041	190	40	16 j6	5	18	M6
IHR051	200	50	24 j6	8	27	M8
IHR061	215	50	24 j6	8	27	M8
IHR081	248	60	28 j6	8	31	M10
IHR101	306,5	80	38 k6	10	41	M12
IHR121	336,5	80	38 k6	10	41	M12

3.1.14 H..2/3

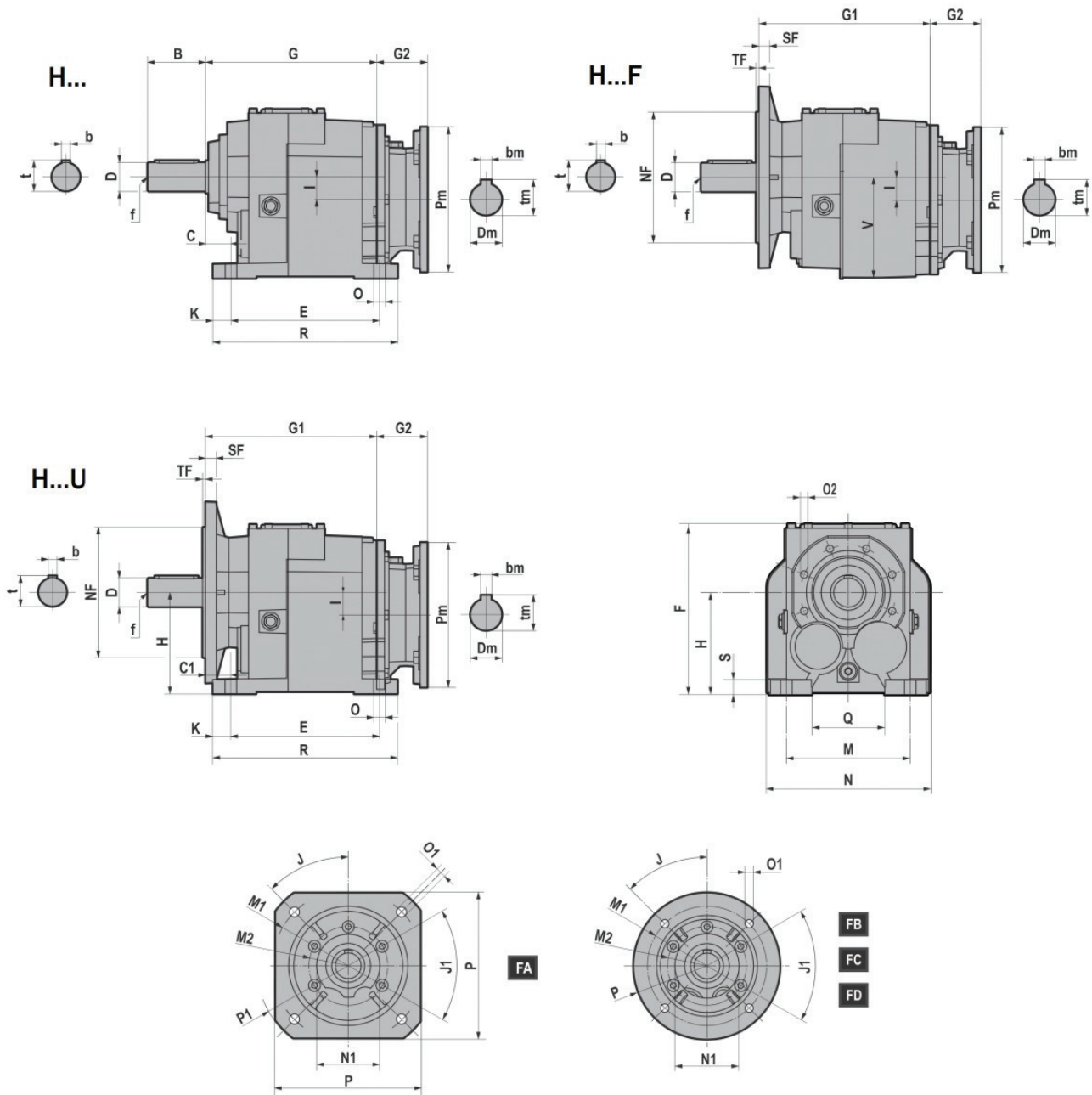

H.../F/U	D	B	b	t	f	C	C1	E	F	G	G1	H	I	K	M	N	O	O2	Q	R	S	-V
H032/H033	25 j6	50	8	28	M10	25	34	130	169	141	150	90	9,2	15	110	140	11	M8x17 (n.5)	60	160	15	92
H042/H043	30 j6	60	8	33	M10	30	30	165	189	152	152	115	18	15	135	170	14	M8x17 (n.5)	85	195	15	115
H052/H053	35 k6	70	10	38	M12	30	30	165	192	187	187	115	25,5	18	135	185	14	M8x17 (n.5)	80	201	18	116
H062/H063	40 k6	80	12	43	M16	35	35	205	234	236	236	140	31	25	170	220	16	M10x20 (n.6)	100	255	20	140
	35 k6	70	10	38	M12																	
H082/H083	50 k6	100	14	53,5	M16	40	40	260	292	272,5	272,5	180	31	27,5	215	280	18	M12x25 (n.7)	140	315	25	180
	40 k6	80	12	43	M16																	
H102/H103	60 m6	120	18	64	M20	40	40	310	364	316	316	225	35,5	27,5	250	330	22	M14x28 (n.7)	159	365	30	227
H122/H123	70 m6	140	20	74,5	M20	45	45	370	399	376,5	376,5	250	47,5	35	290	406	26	M14x30 (n.7)	185,5	440	35	253
H142/H143	90 m6	170	25	95	M20	50	50	410	490	430	430	315	45	40	340	450	26	M16x32 (n.7)	230	490	35	320

3.1 REDUCERS/GEARED MOTORS

....F/U		J	J1	M1	M2	NF f8	N1	O1	P	P1	SF	TF
H032/H033 H042/H043	FA	45	45	Ø165	Ø85	130	70	11	160	Ø200	9	3,5
	FB			Ø130	Ø85	110		9	Ø160	/	9	3,5
	FC			Ø115	Ø85	95		9	Ø140	/	9	3
	FD			Ø100	Ø85	80		M8	Ø120	/	9	3
H052/H053	FA	45	45	Ø215	Ø105	180	90	14	200	Ø250	12	4
	FB			Ø165	Ø105	130		11	Ø200	/	12	3,5
H062/H063	FA	45	45	Ø265	Ø130	230	110	14	250	Ø300	15	4
	FB			Ø215	Ø130	180		14	Ø250	/	15	4
	FC			Ø165	Ø130	130		11	Ø200	/	15	3,5
H082/H083	FA	45	45	Ø300	Ø165	250	130	18	300	Ø350	16	5
	FB			Ø265	Ø165	230		14	Ø300	/	16	4
	FC			Ø215	Ø165	180		14	Ø250	/	16	4
H102/H103	FA	45	45	Ø350	Ø185	300	150	18	350	Ø400	18	5
	FB			Ø300	Ø185	250		18	Ø350	/	18	5
	FC			Ø265	Ø185	230		14	Ø300	/	18	4
H122/H123	FB	45	45	Ø350	Ø200	300	170	18	Ø400	/	18	5
H142/H143	FB	22,5	45	Ø400	Ø245	350	210	18	Ø450	/	25	5
	FC	45		Ø350	Ø245	300		18	Ø400	/	25	5

		G2 H.../F/U			
IEC	Pm x Dm	H032/H033 H042/H043 H052/H053	H062/H063 H082/H083	H102/H103 H122/H123	H142/H143
063	140x11	57,0	/	/	/
071	160x14	69,0	49,0	/	/
080	200x19	90,0	70,0	60,5	/
090	200x24	90,0	70,0	60,5	/
100-112	250x28	105,0	85,0	75,5	/
132	300x38	/	110,0	100,5	76,0
160	350x42	/	157,5	148,0	123,5
180	350x48	/	157,5	148,0	123,5
200	400x55	/	/	185,0	160,5
225	450x60	/	/	/	160,5

B5	Pm	Dm	bm	tm
063	140	11	4	12,8
071	160	14	5	16,3
080	200	19	6	21,8
090	200	24	8	27,3
100	250	28	8	31,3
112	250	28	8	31,3
132	300	38	10	41,3
160	350	42	12	45,3
180	350	48	14	51,8
200	400	55	16	59,3
225	450	60	18	64,4

3.1.15 CH..2/3

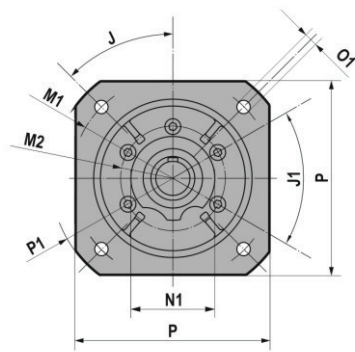
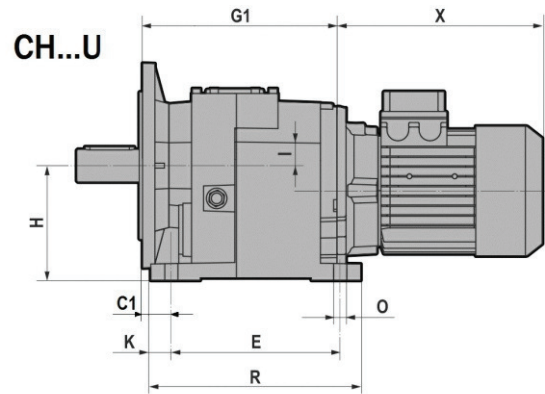
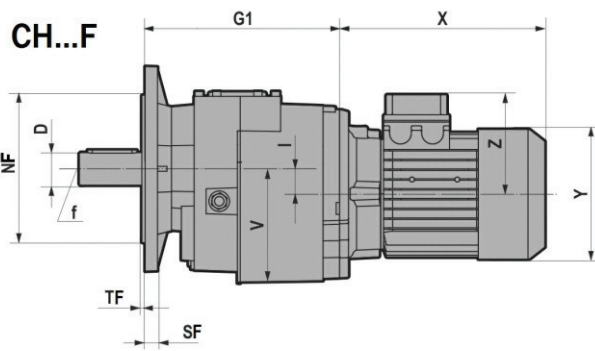
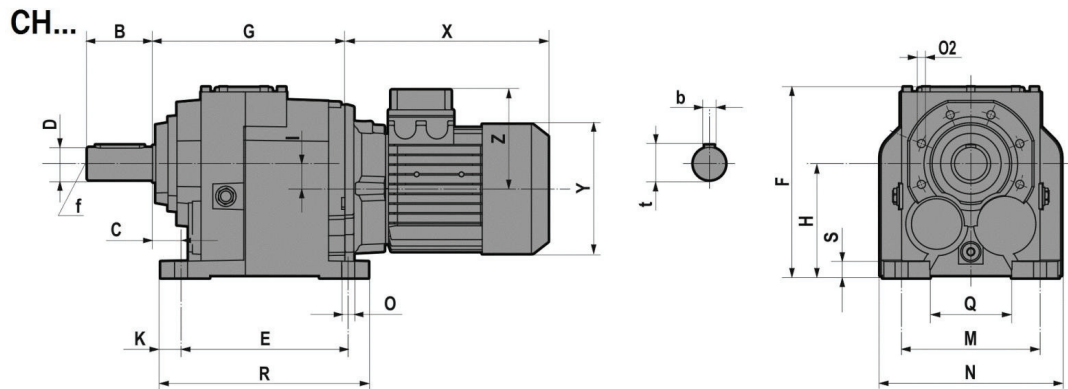

FA

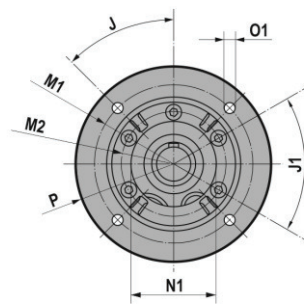

FB

FC

FD

3.1 REDUCERS/GEARED MOTORS

CH.../F/U	D	B	b	t	f	C	C1	E	F	G	G1	H	I	K	M	N	O	O2	Q	R	S	-V
CH032/CH033	25 j6	50	8	28	M10	25	34	130	169	141	150	90	9,2	15	110	140	11	M8x17 (n.5)	60	160	15	92
CH042/CH043	30 j6	60	8	33	M10	30	30	165	189	152	152	115	18	15	135	170	14	M8x17 (n.5)	85	195	15	115
CH052/CH053	35 k6	70	10	38	M12	30	30	165	192	187	187	115	25,5	18	135	185	14	M8x17 (n.5)	80	201	18	116
CH062/CH063	40 k6	80	12	43	M16	35	35	205	234	236	236	140	31	25	170	220	16	M10x20 (n.6)	100	255	20	140
	35 k6	70	10	38	M12																	
CH082/CH083	50 k6	100	14	53,5	M16	40	40	260	292	272,5	272,5	180	31	27,5	215	280	18	M12x25 (n.7)	140	315	25	180
	40 k6	80	12	43	M16																	
CH102/CH103	60 m6	120	18	64	M20	40	40	310	364	316	316	225	35,5	27,5	250	330	22	M14x28 (n.7)	159	365	30	227
CH122/CH123	70 m6	140	20	74,5	M20	45	45	370	399	376,5	376,5	250	47,5	35	290	406	26	M14x30 (n.7)	185,5	440	35	253
CH142/CH143	90 m6	170	25	95	M20	50	50	410	490	430	430	315	45	40	340	450	26	M16x32 (n.7)	230	490	35	320

....F/U		J	J1	M1	M2	NF f8	N1	O1	P	P1	SF	TF
CH032/CH033 CH042/CH043	FA	45	45	Ø165	Ø85	130	70	11	160	Ø200	9	3,5
	FB			Ø130	Ø85	110		9	Ø160	/	9	3,5
	FC			Ø115	Ø85	95		9	Ø140	/	9	3
	FD			Ø100	Ø85	80		M8	Ø120	/	9	3
CH052/CH053	FA	45	45	Ø215	Ø105	180	90	14	200	Ø250	12	4
	FB			Ø165	Ø105	130		11	Ø200	/	12	3,5
CH062/CH063	FA	45	45	Ø265	Ø130	230	110	14	250	Ø300	15	4
	FB			Ø215	Ø130	180		14	Ø250	/	15	4
	FC			Ø165	Ø130	130		11	Ø200	/	15	3,5
CH082/CH083	FA	45	45	Ø300	Ø165	250	130	18	300	Ø350	16	5
	FB			Ø265	Ø165	230		14	Ø300	/	16	4
	FC			Ø215	Ø165	180		14	Ø250	/	16	4
CH102/CH103	FA	45	45	Ø350	Ø185	300	150	18	350	Ø400	18	5
	FB			Ø300	Ø185	250		18	Ø350	/	18	5
	FC			Ø265	Ø185	230		14	Ø300	/	18	4
CH122/CH123	FB	45	45	Ø350	Ø200	300	170	18	Ø400	/	18	5
CH142/CH143	FB	22,5	45	Ø400	Ø245	350	210	18	Ø450	/	25	5
	FC	45		Ø350	Ø245	300		18	Ø400	/	25	5

T (IE1 - IE2)										
CH.../F/U	063	071	080	090S	090L	100	112	132S	132M/L	
CH032/CH033 CH042/CH043 CH052/CH053	X	215	241	268	296	321	333	351	/	/
	Y	121	139	158	173	173	191	211	/	/
	Z	104	112	122	130	130	139	154	/	/
CH062/CH063 CH082/CH083	X	/	221	248	276	301	335	356	405	443
	Y	/	139	158	173	173	191	211	249	249
	Z	/	112	122	130	130	139	154	194	194
CH102/CH103 CH122/CH123	X	/	/	/	267	292	326	347	396	434
	Y	/	/	/	173	173	191	211	249	249
	Z	/	/	/	130	130	139	154	194	194

TB (IE1 - IE2)										
CH.../F/U	063	071	080	090S	090L	100	112	132S	132M/L	
CH032/CH033 CH042/CH043 CH052/CH053	X	273	306.5	341	373	398	415	448	/	/
	Y	121	139	158	173	173	191	211	/	/
	Z	119	129	137	157	157	168	183	/	/
CH062/CH063 CH082/CH083	X	/	286.5	321	353	378	417	453	505	547
	Y	/	139	158	173	173	191	211	249	249
	Z	/	129	137	157	157	168	183	230	230
CH102/CH103 CH122/CH123	X	/	/	/	343	368	407	443	495	537
	Y	/	/	/	173	173	191	211	249	249
	Z	/	/	/	157	157	168	183	230	230

3.1.16 IH...2/3

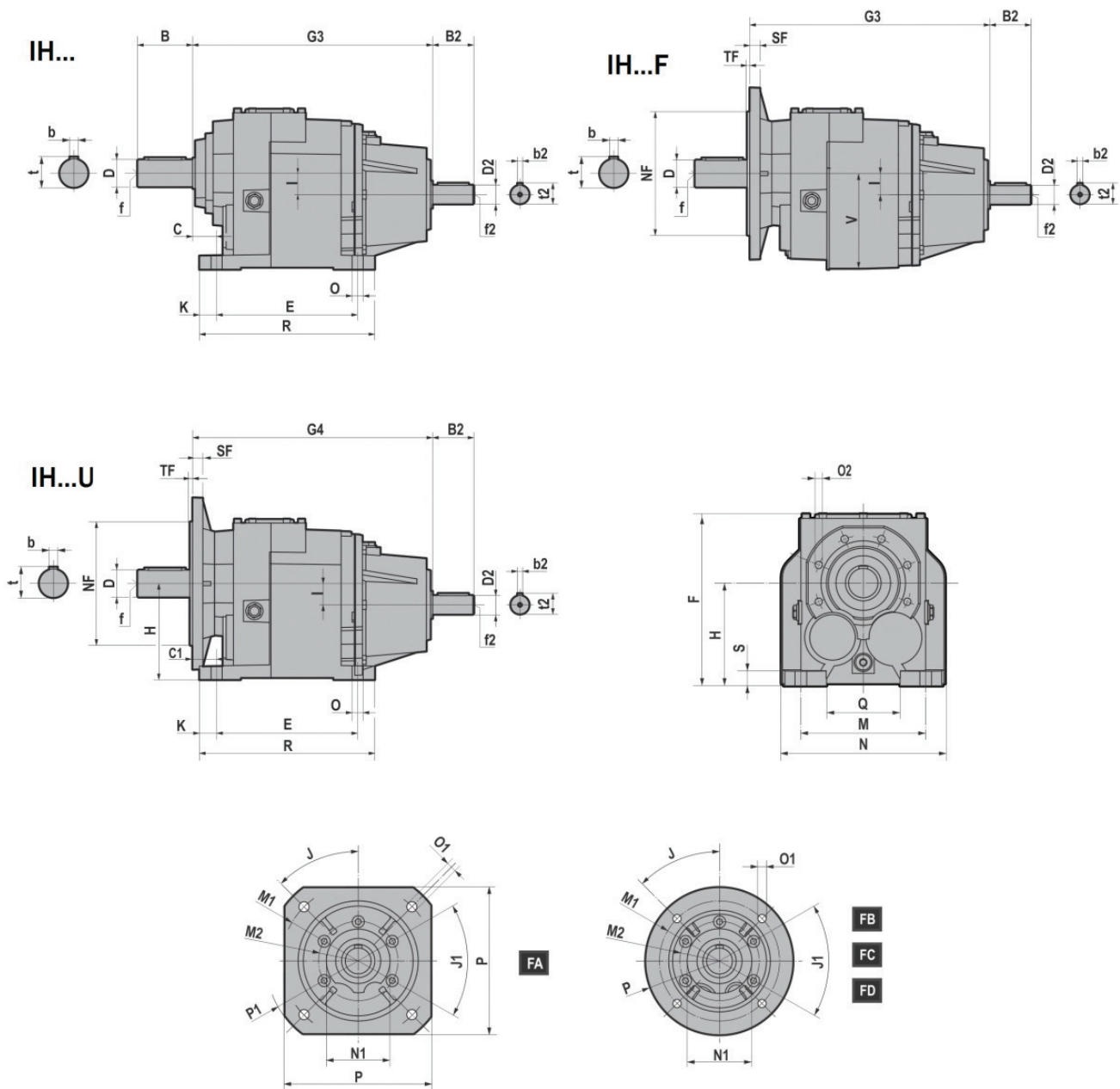

IH.../F/U	D	B	b	t	f	C	C1	E	F	G	G1	H	I	K	M	N	O	O2	Q	R	S	-V
IH032/IH033	25 j6	50	8	28	M10	25	34	130	169	141	150	90	9,2	15	110	140	11	M8x17 (n.5)	60	160	15	92
IH042/IH043	30 j6	60	8	33	M10	30	30	165	189	152	152	115	18	15	135	170	14	M8x17 (n.5)	85	195	15	115
IH052/IH053	35 k6	70	10	38	M12	30	30	165	192	187	187	115	25,5	18	135	185	14	M8x17 (n.5)	80	201	18	116
IH062/IH063	40 k6	80	12	43	M16	35	35	205	234	236	236	140	31	25	170	220	16	M10x20 (n.6)	100	255	20	140
	35 k6	70	10	38	M12																	
IH082/IH083	50 k6	100	14	53,5	M16	40	40	260	292	272,5	272,5	180	31	27,5	215	280	18	M12x25 (n.7)	140	315	25	180
	40 k6	80	12	43	M16																	
IH102/IH103	60 m6	120	18	64	M20	40	40	310	364	316	316	225	35,5	27,5	250	330	22	M14x28 (n.7)	159	365	30	227
IH122/IH123	70 m6	140	20	74,5	M20	45	45	370	399	376,5	376,5	250	47,5	35	290	406	26	M14x30 (n.7)	185,5	440	35	253
IH142/IH143	90 m6	170	25	95	M20	50	50	410	490	430	430	315	45	40	340	450	26	M16x32 (n.7)	230	490	35	320

3.1 REDUCERS/GEARED MOTORS

...F/U		J	J1	M1	M2	NF f8	N1	O1	P	P1	SF	TF
IH032/IH033 IH042/IH043	FA	45	45	Ø165	Ø85	130	70	11	160	Ø200	9	3,5
	FB			Ø130	Ø85	110		9	Ø160	/	9	3,5
	FC			Ø115	Ø85	95		9	Ø140	/	9	3
	FD			Ø100	Ø85	80		M8	Ø120	/	9	3
IH052/IH053	FA	45	45	Ø215	Ø105	180	90	14	200	Ø250	12	4
	FB			Ø165	Ø105	130		11	Ø200	/	12	3,5
IH062/IH063	FA	45	45	Ø265	Ø130	230	110	14	250	Ø300	15	4
	FB			Ø215	Ø130	180		14	Ø250	/	15	4
	FC			Ø165	Ø130	130		11	Ø200	/	15	3,5
IH082/IH083	FA	45	45	Ø300	Ø165	250	130	18	300	Ø350	16	5
	FB			Ø265	Ø165	230		14	Ø300	/	16	4
	FC			Ø215	Ø165	180		14	Ø250	/	16	4
IH102/IH103	FA	45	45	Ø350	Ø185	300	150	18	350	Ø400	18	5
	FB			Ø300	Ø185	250		18	Ø350	/	18	5
	FC			Ø265	Ø185	230		14	Ø300	/	18	4
IH122/IH123	FB	45	45	Ø350	Ø200	300	170	18	Ø400	/	18	5
IH142/IH143	FB	22,5	45	Ø400	Ø245	350	210	18	Ø450	/	25	5
	FC	45		Ø350	Ø245	300		18	Ø400	/	25	5

IH.../F/U	G3	G4	B2	D2	b2	t2	f2
IH032/IH033	231	240	50	24 j6	8	27	M8
IH042/IH043	242	242	50	24 j6	8	27	M8
IH052/IH053	277	277	50	24 j6	8	27	M8
IH062/IH063	349	349	60	28 j6	8	31	M10
IH082/IH083	385,5	385,5	60	28 j6	8	31	M10
IH102/IH103	442,5	442,5	80	38 k6	10	41	M12
IH122/IH123	503	503	80	38 k6	10	41	M12
IH142/IH143	570	570	110	42 k6	12	45	M16