

Mechanical Linear Actuators

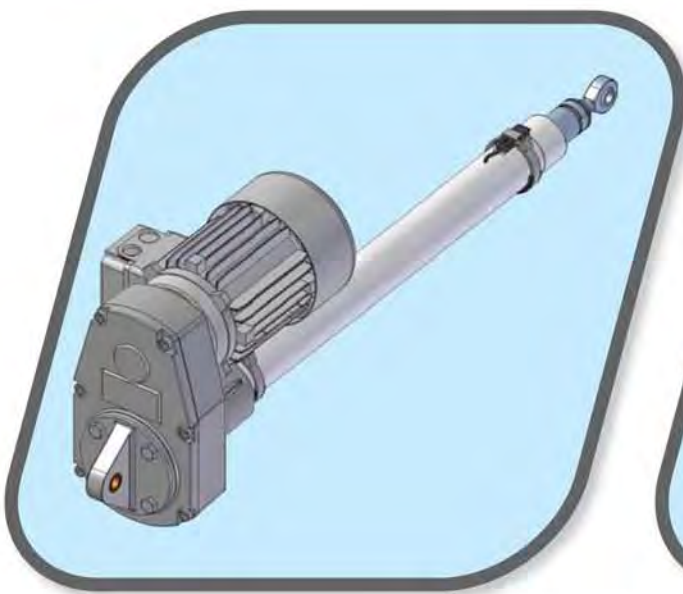
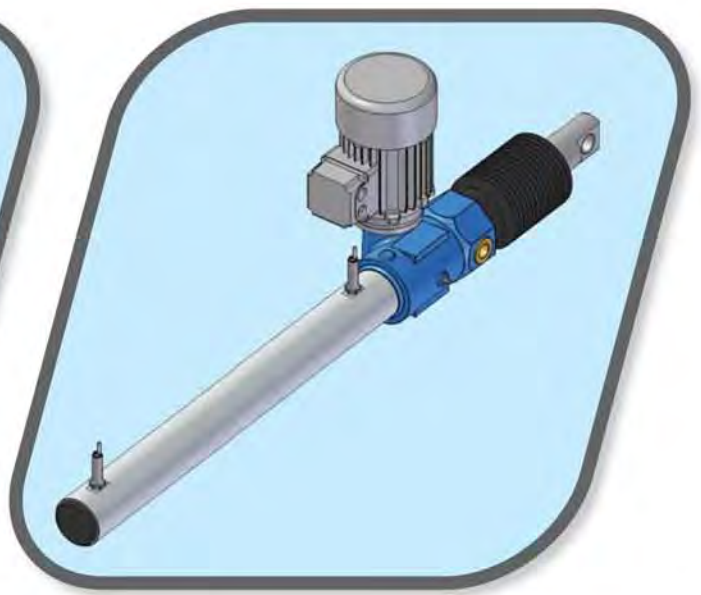
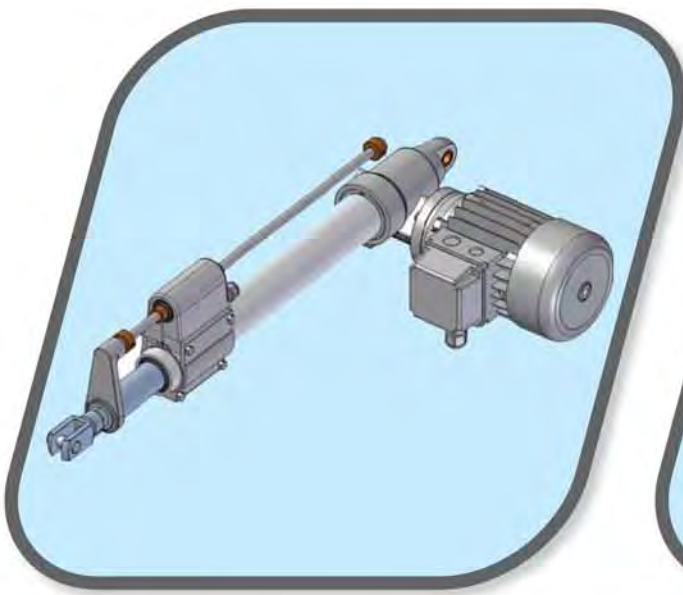

© **Copyright SERVOMECH**

This catalogue contents are under publisher copyright and may not be reproduced unless permission is agreed. Every care has been taken to ensure the accuracy of the information contained in this catalogue, but no liability can be accepted for any errors or omissions.

INDEX

1. General Information

1.1	SERVOMECH linear actuators	page	3
1.2	SERVOMECH linear actuators range	page	4
1.3	Linear actuator selection	page	9
1.4	1 st approximation selection diagrams	page	17
1.5	Buckling resistance under push load - Euler diagrams	page	23
1.6	Ball screw lifetime – performed stroke related to load	page	30
1.7	Ball screw lifetime related to load and linear speed	page	33
1.8	Actuator duty cycle permissible F_i related to dynamic load and speed	page	38
1.9	Self-locking conditions	page	39

2. Linear Actuators ATL Series and BSA Series

2.1	Manufacturing features	page	41
2.2	Technical data	page	42
2.3	Performances	page	46
2.4	Overall dimensions	page	54
2.5	Options and accessories	page	82
2.6	Special arrangements	page	96
2.7	Ordering code	page	97
2.8	Selection data sheet	page	98
2.9	Check sheet	page	100

3. Linear Actuators CLA Series and CLB Series

3.1	Manufacturing features	page	103
3.2	Technical data	page	104
3.3	Performances	page	106
3.4	Overall dimensions	page	108
3.5	Options and accessories	page	114
3.6	Special arrangements	page	120
3.7	Ordering code	page	122
3.8	Selection data sheet	page	123
3.9	Check sheet	page	124

4. Linear Actuators UBA Series and UAL Series

4.1	Manufacturing features	page	127
4.2	Technical data	page	128
4.3	Performances	page	130
4.4	Overall dimensions	page	136
4.5	Options and accessories	page	146
4.6	Special arrangements	page	151
4.7	Ordering code	page	152
4.8	Selection data sheet	page	153
4.9	Check sheet	page	154

5. Linear Actuators TMA Series

5.1	Manufacturing features	page	157
5.2	Technical data	page	158
5.3	Performances	page	160
5.4	Configurations	page	162
5.5	Overall dimensions	page	164
5.6	Options and accessories	page	173
5.7	Special arrangements	page	178
5.8	Ordering code	page	180
5.9	Selection data sheet	page	181
5.10	Check sheet	page	182

6. Linear Actuators ILA Series

6.1	Manufacturing features	page 185
6.2	Technical data	page 186
6.3	Overall dimensions	page 190
6.4	Options and accessories	page 194
6.5	Ordering code	page 196
6.6	Selection data sheet	page 197
6.7	Check sheet	page 198

7. Electric motors

7.1	AC 3-phase electric motors	page 200
7.2	AC 1-phase electric motors	page 200
7.3	DC electric motors	page 200
7.4	Brake-motor: when it is required	page 201

8. Additional Information

8.1	Product nameplate	page 202
8.2	Conditions on delivery	page 202
8.3	Installation – Maintenance – Lubrication	page 203
8.4	General terms of sale	page 203
8.5	Lubricants	page 204

1.1 SERVOMECH Linear actuators

SERVOMECH mechanical linear actuators are motorised mechanical cylinders able to transform the rotary motion of a motor into the linear motion of a push rod.

They are designed and manufactured for industrial applications, even the heaviest in terms of:

- applied load
- linear speed
- duty cycle
- environmental conditions.

They are able to work under push or pull load.

According to their configuration, they can be:

- statically self-locking - able to sustain static load keeping the same position when the motor is switched off;
- statically non self-locking - in this case the load must be sustained with a brake motor.

They operate at constant linear speed with and without load, with low noise level.

Their operation can be just a simple push-pull “ON-OFF” action or they can become real servo-mechanisms, able to work as controlled axes by means of accessories such as encoders or potentiometers for positioning control, motors with tacho-generator and servo drives.

Their installation is simple and not expensive since it requires just a front and rear hinging as for standard hydraulic and pneumatic cylinders.

Linear actuators can effectively replace pneumatic or hydraulic cylinders for several reasons:

- uniformity in push-pull motion
- accuracy in stopping position
- position holding under load (self-locking)
- energy consumption during operation only
- installation in difficult environments, only electrical control cables are required
- higher safety in load lifting (internal mechanical safety devices available)
- can be used in ambients with very low temperature without freezing risk
- can be used in ambients with very high temperature without fire risk.

SERVOMECH linear actuators have a wide application field. They are intended for industrial applications which require safe operation and/or linear motion control while moving, turning over or lifting a load.

The wide range of sizes, stroke lengths, motor types, linear speeds and available accessories enables to adapt these products for new applications, replace even complex mechanical solutions and hydraulic or pneumatic cylinders, improving the result in terms of performance and with economical advantages.

1.2 SERVOMECH linear actuators range

SERVOMECH linear actuators range consists of **5 actuator groups** determined by their different design, input drive and fixing type.

SERVOMECH Linear Actuators

1.2 SERVOMECH linear actuators range

Linear actuators **ATL Series:**

- input drive: worm gear drive
- linear drive: 1 or more starts acme screw

Linear actuators **BSA Series:**

- input drive: worm gear drive
- linear drive: ball screw

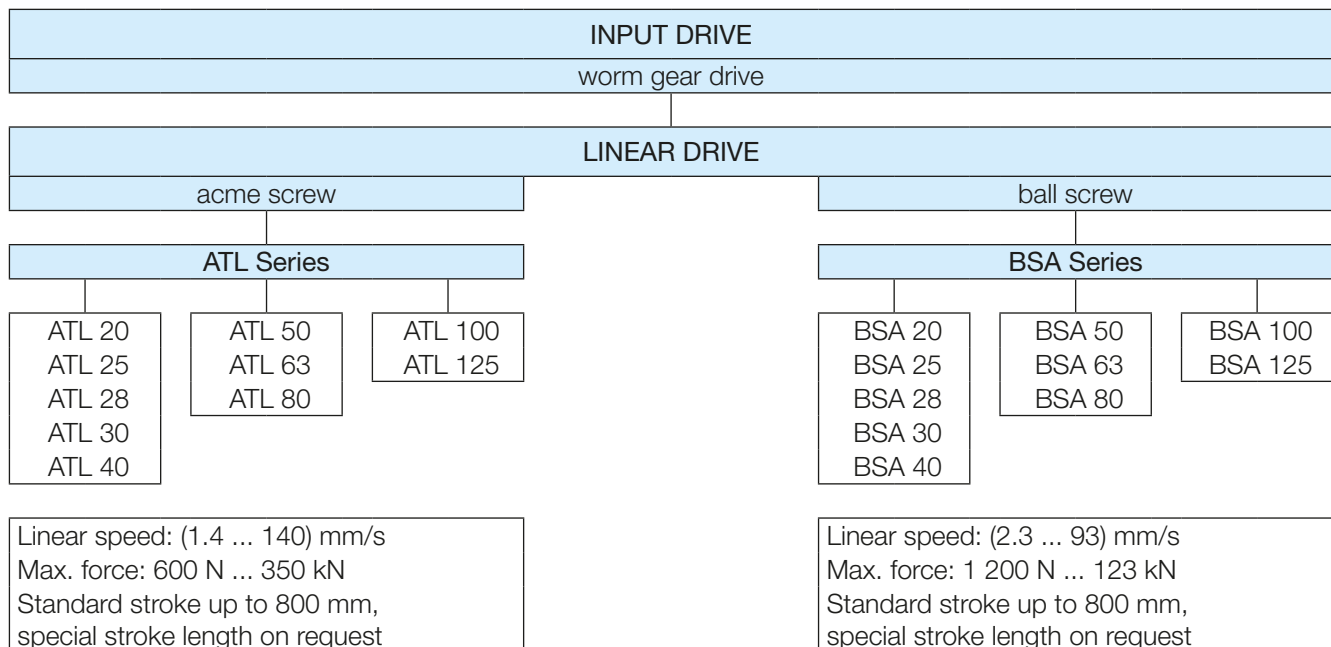
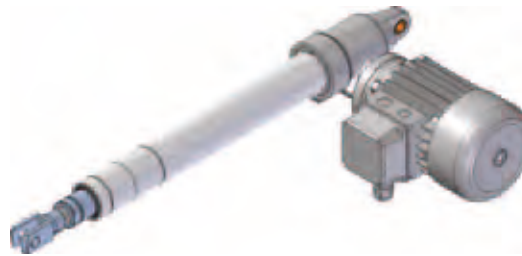

Input shaft axis at 90° with respect to actuator axis

Input:

- attachment for IEC electric motor
- solid shaft

Electric motor:

- AC 3-phase or 1-phase
- DC 24 V or 12 V

Stroke end switches:

- electric switches, activated by adjustable rings along the support rod
- magnetic reed switches, adjustable position along the outer tube
- proximity switches, fix position on outer tube
- cam-operated electric switches, fix position on outer tube

Positioning control:

- rotary encoder on the input shaft
- linear potentiometer mounted parallel to the push rod

Wide range of accessories

It is possible to create drive systems consisting of two or more actuators whose input shafts are mechanically connected by transmission shafts.

SERVOMECH Linear Actuators

1.2 SERVOMECH linear actuators range

Linear actuators **CLA Series:**

- input drive: worm gear drive
- linear drive: 1 or more starts acme screw

Linear actuators **CLB Series:**

- input drive: worm gear drive
- linear drive: ball screw

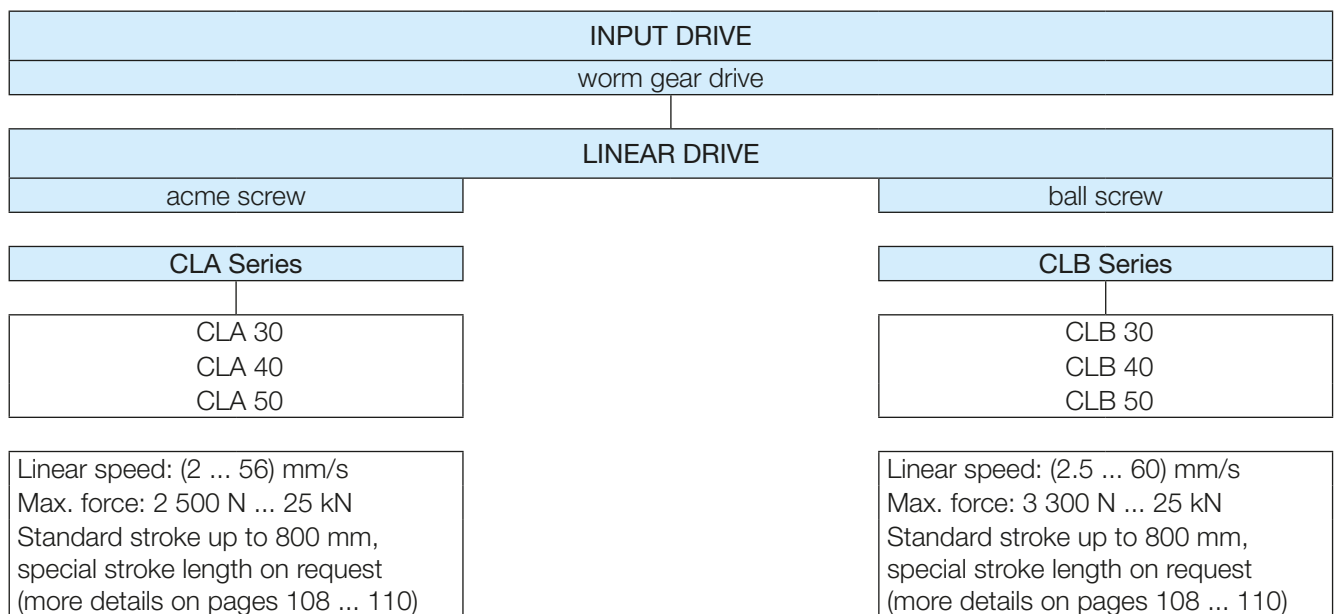
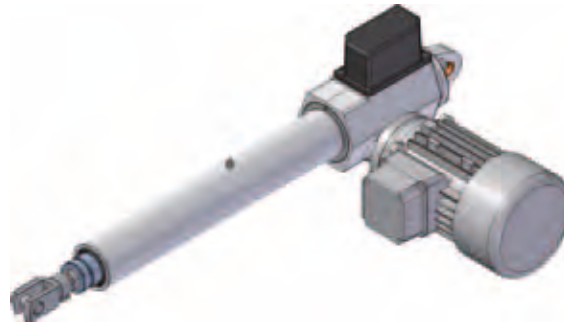

Input shaft axis at 90° with respect to actuator axis

Input:

- attachment for IEC electric motor
- solid shaft

Electric motor:

- AC 3-phase or 1-phase

Stroke end switches:

- adjustable cam-operated electric switches

Positioning control:

- rotary potentiometer

Wide range of accessories

It is possible to create drive systems consisting of two or more actuators whose input shafts are mechanically connected by transmission shafts.

SERVOMECH Linear Actuators

1.2 SERVOMECH linear actuators range

Linear actuators **UBA Series:**

- input drive: timing belt transmission
- linear drive: ball screw

Linear actuators **UAL Series:**

- input drive: timing belt transmission
- linear drive: 1 or more starts acme screw

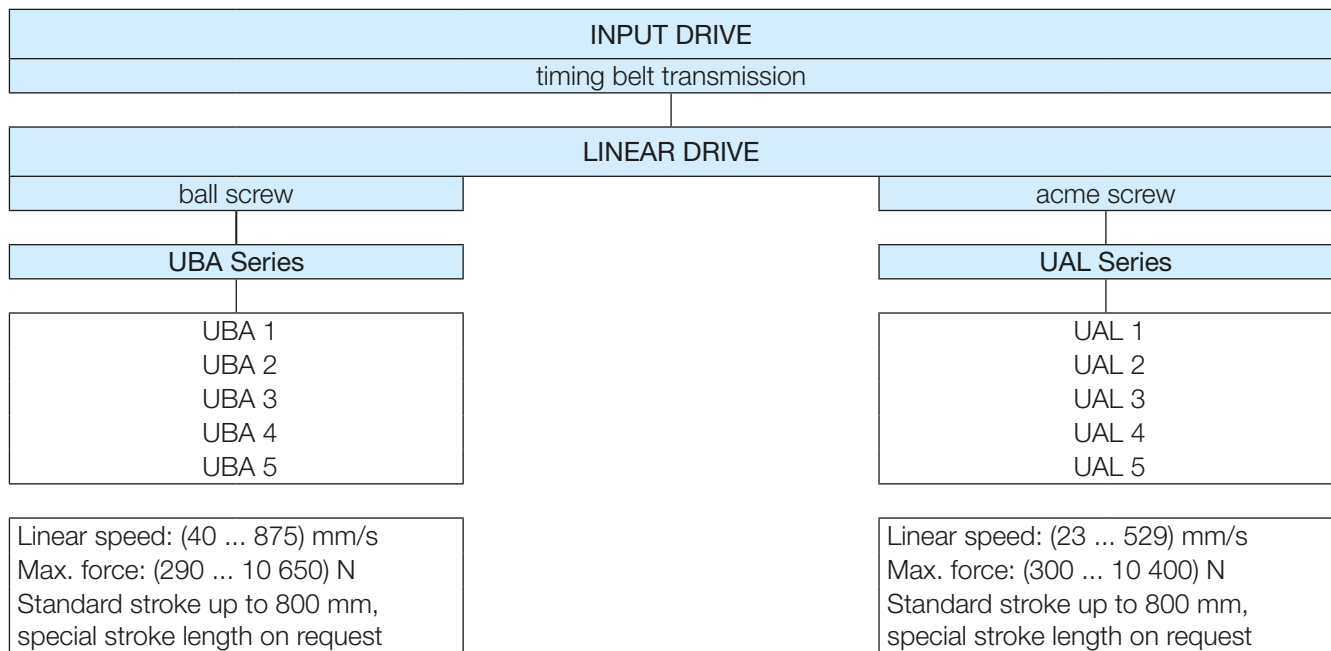
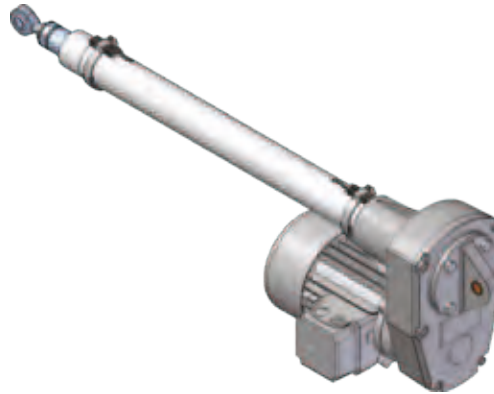

Motor axis parallel to actuator axis

Input:

- attachment for IEC electric motor

Electric motor:

- AC 3-phase or 1-phase **with brake**
- DC 24 V or 12 V **with brake**

Stroke end switches:

- magnetic reed switches, adjustable position along the outer tube
- proximity switches, fix position on outer tube

Positioning control:

- rotary encoder on the input axis
- linear potentiometer mounted parallel to the push rod

Wide range of accessories

SERVOMECH Linear Actuators

1.2 SERVOMECH linear actuators range

Linear actuators **TMA Series:**

- input drive: worm gear drive
- linear drive: 1-start acme screw

INPUT DRIVE
worm gear drive

LINEAR DRIVE
acme screw

TMA Series
TMA 15
TMA 25
TMA 50
TMA 100
TMA 150
TMA 200

Linear speed: (0.12 ... 40) mm/s
Max. force: (2.6 ... 200) kN
Stroke up to 1 500 mm



Trunnion mounted housing fixed with pins or bronze bushes

Input shaft axis at 90° with respect to actuator axis

Input:

- attachment for IEC electric motor
- solid shaft

Electric motor:

- AC 3-phase

Stroke end switches:

- proximity switches, fix position on outer tube
- cam-operated electric switches, fix position on outer tube

Positioning control:

- rotary encoder on the input shaft

Wide range of accessories

It is possible to create drive systems consisting of two or more actuators whose input shafts are mechanically connected by transmission shafts.

SERVOMECH Linear Actuators

1.2 SERVOMECH linear actuators range

Linear actuators **ILA Series:**

- linear drive: 1 or more starts acme screw (**ILA . A Series**)
- linear drive: ball screw (**ILA . B Series**)

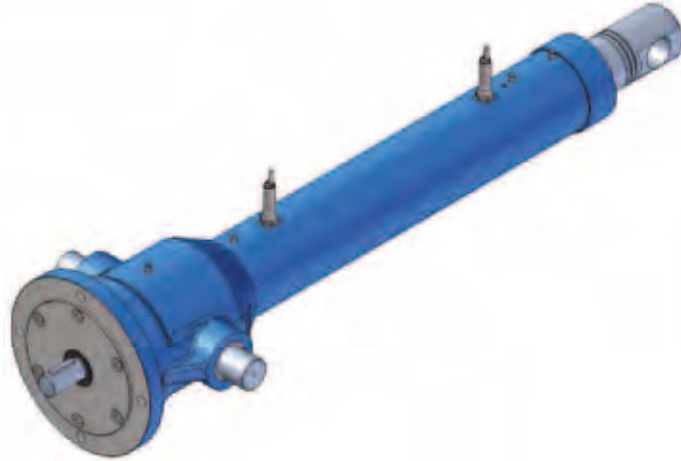

INPUT DRIVE	
acme screw	ball screw
ILA . A Series	ILA . B Series
ILA 15 A ILA 25 A ILA 50 A ILA 100 A ILA 150 A ILA 200 A	ILA 15 B ILA 25 B ILA 50 B ILA 100 B ILA 150 B ILA 200 B
Max. force: (15 ... 200) kN Stroke up to 1 500 mm	Max. force: (15 ... 200) kN Stroke up to 1 500 mm

IN-LINE actuators

Housing mounting with pins

Input: shaft and flange as input drive attachment

Stroke end switches:

- proximity switches, fixed position on outer tube

Wide range of accessories

1.3 Linear actuator selection

THERMAL LIMIT

Linear actuators transform the rotary motion into a linear motion. This transformation involves a dissipation of energy in the form of heat. Therefore, to choose the right actuator for an application it is necessary to take into account the **APPLICATION DUTY CYCLE REQUIRED** and compare it with the **ACTUATOR DUTY CYCLE PERMISSIBLE**.

The **APPLICATION DUTY CYCLE REQUIRED** F_u [%] is the ratio expressed in percentage between the actual working time under load during the reference time period of 10 minutes and the reference period itself.

$$F_u \text{ [%]} = \frac{\text{Working time over 10 min}}{10 \text{ min}} \times 100$$

The **ACTUATOR DUTY CYCLE PERMISSIBLE** F_i [%] is the maximum working time expressed in percentage that the actuator can perform during the reference time period of 10 minutes, under maximum rated load stated in this catalogue at ambient temperature 25°C, without risk of internal parts overheating.

Linear drive	F_i [%]
1-start acme screw	30
ball screw	100

For the proper operation of a linear actuator, the condition $F_u \leq F_i$ must be satisfied. Therefore, the real limit for the actuator working time is often the thermal limit and not its structural strength nor the motor power. In order to make the right selection of an actuator we recommend following **SELECTION PROCEDURE** below.

LINEAR ACTUATOR SELECTION PROCEDURE

1. Identify the performances and technical specifications required by the application

- stroke
- linear speed
- dynamic load, pull - push, current stroke corresponding to the max. push load value
- static load, pull – push, current stroke corresponding to the max. push load value
- working cycle
- type of motor required

2. Determine the type of linear drive

Considering the **STROKE**, the **LINEAR SPEED** and the **WORKING CYCLE**, calculate the **APPLICATION DUTY CYCLE REQUIRED** F_u [%] over 10 min:

- with $F_u \leq 30$ %: select acme screw actuators
- with $F_u \geq 50$ %: select ball screw actuators
- with 30 % < F_u < 50 % there are 2 possibilities:
 - select ball screw linear actuators, as a precaution;
 - select acme screw linear actuators, previous accurate check of the permissible load for a duty cycle higher than 30 % (refer to diagram **DUTY CYCLE F_i RELATED TO DYNAMIC LOAD AND SPEED** on page 38).

Generally, ball screw actuators are more expensive than their equivalent with acme screw. On the other hand, the selection of acme screw actuators in case of $F_u > 30$ %, implies a reduced performance and it is necessary to select a larger size.

Ball screw actuators are not self-locking and require a brake motor to ensure static load holding. Furthermore, a brake motor is also necessary whenever a precise positioning and stopping repeatability are required, with both ball screw and acme screw actuators.

In any case, a brake motor is required for high linear speeds.

Therefore, in this condition the choice between ball screw or acme screw actuators is influenced not only by technical factors but also by economic reasons.

1.3 Linear actuator selection

3. Select the size as a 1st approximation

Referring to the force and the linear speed required by the application, use the 1st APPROXIMATION SELECTION DIAGRAMS, according to the linear drive type as determined in the previous step (see pages 17 ... 22), to select the actuator size.

4. Mechanical checks

4.1 Structural stability check

Referring to the max. push load and the stroke, check the structural stability – buckling resistance under push load - of the actuator selected in the previous step. This check should be carried out for push load and long strokes referring to diagrams on pages 23 ... 29.

4.2 Lifetime check

- Acme screw actuators

The performances stated in this catalogue are the maximum permissible, considering duty cycle $F_i = 30\%$ over a time period of 10 min and ambient temperature 25°C. Besides the load, the lifetime is strongly influenced also by the linear speed, the ambient temperature and the duty cycle. For a more precise evaluation contact SERVOMECH.

- Ball screw actuators

The performances stated in this catalogue are the maximum permissible with max. duty cycle 100%, ambient temperature 25°C and minimum lifetime $L_{10h} = 1000$ hours.

For a different lifetime refer to the diagrams on pages 30 ... 38.

The previously selected size can be confirmed, otherwise the next larger size shall be selected.

5. Determine the actuator ratio

According to the required motor type, the series and the size of the selected actuator, see the relative PERFORMANCE TABLE and find the RATIO which gives the required performance in terms of LOAD and SPEED. Choose the performance nearest to those required. If necessary, select the next size to fully satisfy the required performance.

6. Check the thermal limit

- For acme screw actuators and $F_u \leq 30\%$ only: according to the working cycle, considering the actual speed of the actuator, calculate the actual DUTY CYCLE F_u and verify that it is not higher than the DUTY CYCLE F_i permissible by the selected actuator ($F_u \leq F_i$). Otherwise, considering the difference $F_u - F_i$, decide if the selection can be confirmed or if the next bigger size should be chosen.

- For acme screw actuators and $30\% < F_u < 50\%$ only: refer to diagram DUTY CYCLE F_i RELATED TO DYNAMIC LOAD AND SPEED on page 38 and check the dynamic load permissible by the selected actuator.

7. Select accessories and/or options

- 7.1 Front attachment
- 7.2 Stroke end switches
- 7.3 Input version
- 7.4 Other accessories

8. Check actuator dimensions and fixing accessories

Refer to the dimensional tables to know the over-all dimensions of the actuator and relevant accessories and verify if they suit the application.

9. Complete the ordering code

Refer to the example shown at the end of the chapter regarding the selected actuator series.



1.3 Linear actuator selection

Example 1:

1. Application data

- stroke: 300 mm
- linear speed: 20 mm/s
- dynamic load: 4 500 N, push, constant along the entire stroke forward and backward
- static load: 4 500 N, push, applied in any position of the stroke
- working cycle: 5 complete travels (forward + backward) in 10 min
- motor: AC 3-phase electric motor
- application layout

2. Determination of the linear drive type

Calculation of the DUTY CYCLE F_u [%] over 10 min:

$$F_u = \frac{2 \times \text{STROKE}}{\text{LIN.SPEED}} \times \frac{\text{Nr. of cycles over ref. time period}}{\text{Ref. time period}} \times 100 = \frac{2 \times 300 \text{ mm}}{20 \frac{\text{mm}}{\text{s}}} \times \frac{5}{10 \text{ min} \times 60 \frac{\text{s}}{\text{min}}} \times 100 = 25 \%$$

With $F_u \leq 30 \%$, the correct selection is an acme screw actuator.

3. Size selection as a 1st approximation

Referring to the 1st APPROXIMATION SELECTION DIAGRAMS for acme screw actuators on pages 17 ... 20:

- considering the LINEAR SPEED of 20 mm/s select the **ATL Series**
- considering the MAX. DYNAMIC LOAD of 4500 N at LINEAR SPEED of 20 mm/s select the **SIZE 30**.

4.1 Check of structural stability

Referring to the diagram BUCKLING RESISTANCE UNDER PUSH LOAD for **ATL Series** on page 23, for PUSH LOAD of 4500 N and STROKE of 300 mm, selection of the actuator **ATL 30** is CORRECT.

5. Determination of ratio

Referring to the ACME SCREW LINEAR ACTUATORS **ATL SERIES WITH AC 3-PHASE MOTOR PERFORMANCES** table on page 46, the performances of the actuator **ATL 30** with RATIO **RN2** and 3-PHASE **0.25 kW 2-pole MOTOR**

LINEAR SPEED: 23 mm/s DYNAMIC LOAD: 5200 N

are sufficiently closed to the required performances.

6. Check of thermal limit

$F_u \leq 30 \%$: considering the actual speed of the selected actuator, calculate the DUTY CYCLE F_u [%] over 10 min:

$$F_u = \frac{2 \times 300 \text{ mm}}{23 \frac{\text{mm}}{\text{s}}} \times \frac{5}{10 \text{ min} \times 60 \frac{\text{s}}{\text{min}}} \times 100 = 22 \%$$

The calculated value is lower than the duty cycle permissible by the actuator (for acme screw actuators $F_i = 30 \%$, see page 9), therefore the selection of actuator **ATL 30 RN2** is CONFIRMED.

7. Accessories and/or options selection

Select the actuator fixing attachments (see pages 54 ... 57), the input version (see page 83), the stroke end switches (see pages 88 ... 92) and/or other accessories and/or options (see page 82 and pages 93 ... 96).

8. Check of actuator dimensions

Referring to actuator overall dimensions (see pages 54 ... 57, according to the selected stroke end switches), verify if the actuator dimensions fit to the application requirements.

9. Ordering code

Complete the ordering code of the selected actuator referring to the example on page 97.

SERVOMECH Linear Actuators

1.3 Linear actuator selection

Example 2:

1. Application data

- stroke: 600 mm
- linear speed: 60 mm/s
- dynamic load: 900 N, push - pull, constant along the entire stroke forward and backward
- static load: 900 N, push, applied in any position of the stroke
- working cycle: 13 complete travels (forward + backward) in 10 min
- motor: DC 24 V **with brake**
- application layout

2. Determination of the linear drive type

Calculation of the DUTY CYCLE F_u [%] over 10 min:

$$F_u = \frac{2 \times \text{STROKE}}{\text{LIN. SPEED}} \times \frac{\text{Nr. of cycles over ref. time period}}{\text{Ref. time period}} \times 100 = \frac{2 \times 600 \text{ mm}}{60 \frac{\text{mm}}{\text{s}}} \times \frac{13}{10 \text{ min} \times 60 \frac{\text{s}}{\text{min}}} \times 100 = 43 \%$$

With $30 \% < F_u < 50 \%$, both acme or ball screw actuator could be chosen. This example shows the selection of an acme screw actuator because the ball screw actuator, with $F_i = 100 \%$, satisfies the condition $F_u \leq F_i$.

3. Size selection as a 1st approximation

Referring to the 1st APPROXIMATION SELECTION DIAGRAMS for acme screw actuators on pages 17 ... 20:

- considering the LINEAR SPEED of 60 mm/s select the **ATL Series**
- considering the MAX. DYNAMIC LOAD of 900 N at LINEAR SPEED of 60 mm/s select the **SIZE 20**.

4.1 Check of structural stability

Referring to the diagram BUCKLING RESISTANCE UNDER PUSH LOAD for **ATL Series** on page 23, for PUSH LOAD of 900 N and STROKE of 600 mm selection of the actuator **ATL 20** is CORRECT.

5. Determination of ratio

Referring to the ACME SCREW LINEAR ACTUATORS **ATL SERIES WITH DC MOTOR PERFORMANCES** table on page 49, the performances of the actuator **ATL 20** with **RATIO RV2** and **DC MOTOR 24 V 100 W 3000 rpm**

LINEAR SPEED: 64 mm/s DYNAMIC LOAD: 920 N

are sufficiently closed to the required performances.

6. Check of thermal limit

$30 \% < F_u < 50 \%$: referring to the diagram DUTY CYCLE F_i RELATED TO DYNAMIC LOAD AND SPEED on page 38, the max. dynamic load permissible with condition $F_i = F_u = 43 \%$ is:

$$0.7 \times 920 = 640 \text{ N}$$

The calculated value is lower than the dynamic load required by the application, therefore the selection of the actuator **ATL 20 RV2** is NOT CORRECT.

5.bis Determination of ratio

Back to the ACME SCREW LINEAR ACTUATORS **ATL SERIES WITH DC MOTOR PERFORMANCES** table on page 49, select the actuator **next larger size**, **ATL 25** with **RATIO RV2** and with **DC MOTOR 24 V 150 W 3000 rpm** with performances

LINEAR SPEED: 64 mm/s DYNAMIC LOAD: 1330 N

which are sufficiently closed to the required performances.

1.3 Linear actuator selection

Example 2 (continuation):

6.bis Check of thermal limit

$30\% < F_u < 50\%$: referring to the diagram DUTY CYCLE F_i RELATED TO DYNAMIC LOAD AND SPEED on page 38, the max. dynamic load permissible with condition $F_i = F_u = 43\%$ is:

$$0.7 \times 1330 = 930 \text{ N}$$

The resulting value is higher than the dynamic load required by the application, therefore the selection of the actuator ATL 25 RV2 is CORRECT.

Considering now the actual speed of the selected actuator, the DUTY CYCLE F_u [%] over 10 min is

$$F_u = \frac{2 \times 600 \text{ mm}}{64 \frac{\text{mm}}{\text{s}}} \times \frac{13}{10 \text{ min} \times 60 \frac{\text{s}}{\text{min}}} \times 100 = 41\%$$

Being this value remained within the limits $30\% < F_u < 50\%$, the selection of the actuator ATL 25 RV2 is CONFIRMED.

7. Accessories and/or options selection

Select the actuator fixing attachments (see pages 58 ... 61), the input version (see page 83), the stroke end switches (see pages 88 ... 92) and/or other accessories and/or options (see page 82 and pages 93 ... 96).

8. Check of actuator dimensions

Referring to actuator overall dimensions (see pages 58 ... 61, according to the selected stroke end switches), verify if the actuator dimensions fit to the application requirements.

9. Ordering code

Complete the ordering code of the selected actuator referring to the example on page 97.

NOTE: Due to the quite high linear speed, it is necessary to use a brake-motor.

SERVOMECH Linear Actuators

1.3 Linear actuator selection

Example 3:

1. Application data

- stroke: 500 mm
- linear speed: 125 mm/s
- dynamic load: 1 800 N, push - pull, constant along the entire stroke forward and backward
- static load: not present
- working cycle: 50 complete travels (forward + backward) in 10 min
- required lifetime: 3 000 hours of work under load
- motor: AC 3-phase **with brake**
- application layout

2. Determination of the linear drive type

Calculation of the DUTY CYCLE F_u [%] over 10 min:

$$F_u = \frac{2 \times \text{STROKE}}{\text{LIN. SPEED}} \times \frac{\text{Nr. of cycles over ref. time period}}{\text{Ref. time period}} \times 100 = \frac{2 \times 500 \text{ mm}}{125 \frac{\text{mm}}{\text{s}}} \times \frac{50}{10 \text{ min} \times 60 \frac{\text{s}}{\text{min}}} \times 100 = 67 \%$$

With $F_u = 67 \%$, the correct selection is a ball screw actuator.

3. Size selection as a 1st approximation

Referring to the 1st APPROXIMATION SELECTION DIAGRAMS for ball screw actuators on pages 21 ... 22:

- considering the LINEAR SPEED of 125 mm/s select the **UBA Series**
- considering the MAX. DYNAMIC LOAD of 1800 N at LINEAR SPEED of 125 mm/s select the **SIZE 2**.

4.1 Check of structural stability

Referring to the diagram BUCKLING RESISTANCE UNDER PUSH LOAD for **UBA Series** on page 26, for PUSH LOAD of 1800 N and STROKE of 500 mm, selection of the actuator **UBA 2** is CORRECT.

4.2 Lifetime check

Referring to the diagram BALL SCREW LIFETIME for ball screw BS 16x5 on page 33, the lifetime of this ball screw with load 1800 N and linear speed 125 mm/s is lower than required 3000 hours, therefore the actuator UBA 2 is NOT CORRECT for the application.

4.2 bis Lifetime check

Select the next larger actuator size: UBA 3. Referring to the diagram BALL SCREW LIFETIME for ball screw BS 20x5 on page 34, the lifetime of this ball screw with load 1800 N and linear speed 125 mm/s is higher than required 3000 hours, therefore the actuator UBA 3 is CORRECT for the application.

5. Determination of ratio

Referring to the BALL SCREW LINEAR ACTUATORS UBA SERIES WITH AC 3-PHASE MOTOR PERFORMANCES table on page 130, the performances of the actuator **ATL 20** with RATIO **RN1** and with 3-PHASE MOTOR **0.55 kW 2-pole**

LINEAR SPEED: 115 mm/s DYNAMIC LOAD: 2750 N

are sufficiently closed to the required performances.

7. Accessories and/or options selection

Select the actuator fixing attachments (see pages 136 ... 137) and/or other accessories and/or options (see pages 146 and 151).

8. Check of actuator dimensions

Referring to actuator overall dimensions (see pages 136 ... 137, according to the selected stroke end switches), verify if the actuator dimensions fit to the application requirements.

9. Ordering code

Complete the ordering code of the selected actuator referring to the example on page 152.

NOTE: Due to the high linear speed, it is necessary to use a brake-motor.

1.3 Linear actuator selection

Example 4:

1. Application data

- stroke: 1 200 mm
- linear speed: 0.4 mm/s
- dynamic load: 50 kN, push, constant along the entire stroke forward and backward
- static load: 95 kN, push, applied in any position of the stroke
- working cycle: 1 (one) travel of 8 mm every 5 min
- motor: AC 3-phase
- application layout

2. Determination of the linear drive type

Calculation of the DUTY CYCLE F_u [%] over 10 min:

$$F_u = \frac{2 \times \text{STROKE}}{\text{LIN. SPEED}} \times \frac{\text{Nr. of cycles over ref. time period}}{\text{Ref. time period}} \times 100 = \frac{2 \times 8 \text{ mm}}{0.4 \frac{\text{mm}}{\text{s}}} \times \frac{1}{2 \times 5 \text{ min} \times 60 \frac{\text{s}}{\text{min}}} \times 100 = 6.7 \%$$

With $F_u \leq 30 \%$, the correct selection is an acme screw actuator.

3. Size selection as a 1st approximation

Referring to the 1st APPROXIMATION SELECTION DIAGRAMS for acme screw actuators on pages 17 ... 20:

- considering the LINEAR SPEED of 0.4 mm/s select the **TMA Series**
- considering the MAX. DYNAMIC LOAD of 50 kN at LINEAR SPEED of 0.4 mm/s select the **SIZE 50**

4.1 Check of structural stability

Referring to the diagram BUCKLING RESISTANCE UNDER PUSH LOAD for **TMA Series** on page 27, for PUSH LOAD of 95 kN is higher than the max. load permissible by the actuator TMA 50, therefore the selection is NOT CORRECT for the application.

4.1 bis Check of structural stability

Select the next larger size: TMA 100. Referring to the diagram BUCKLING RESISTANCE UNDER PUSH LOAD for **TMA Series** on page 27, for PUSH LOAD of 95 kN at STROKE of 1200 mm the selection of the actuator **TMA 100** is CORRECT.

5. Determination of ratio

Referring to the ACME SCREW LINEAR ACTUATORS **TMA SERIES PERFORMANCES** table on page 161, the performances of the actuator **TMA 100** with **RATIO RL1**, with **INPUT GEAR DRIVE I 40 R20** and **3-PHASE MOTOR 0.37 kW 4-pole**

LINEAR SPEED: 0.38 mm/s DYNAMIC LOAD: 100 kN

are sufficiently closed to the required performances.

6. Check of thermal limit

In case of a DUTY CYCLE F_u [%] over 10 min value low as in this example, the check of the thermal limit can be omitted.

7. Accessories and/or options selection

Select the actuator configuration (see pages 162 ... 163), the actuator fixing attachments (see pages 164 ... 171) and/or other accessories and/or options (see pages 177 ... 178).

8. Check of actuator dimensions

Referring to actuator overall dimensions (see pages 164 ... 171 according to the selected configuration) verify if the actuator dimensions fit to the application requirements.

9. Ordering code

Complete the ordering code of the selected actuator referring to the example on page 180.

SERVOMECH Linear Actuators

1.3 Linear actuator selection

Example 5:

1. Application data

- stroke: 600 mm
- linear speed: 400 mm/s
- dynamic load: 4 500 N, push - pull, constant along the entire stroke forward and backward
- static load: not present
- working cycle: continuous work
- motor: servo-motor, in line with the actuator linear drive
- required lifetime: 3 000 hours of work under 4 500 N load
- application layout

2. Determination of the linear drive type

Considering the **continuous** working cycle ($F_u = 100 \%$), select a ball screw actuator.

3. Size selection

Referring to the diagram concerning the BALL SCREW LIFETIME RELATED TO LOAD AND LINEAR SPEED (see pages 33 ... 38), considering the MAX. DYNAMIC LOAD of 4500 N, the LINEAR SPEED of 400 mm/s and the required LIFETIME of 3000 hours, select the BALL SCREW BS 32×10 and therefore linear actuator ILA 25 B.

4.1 Check of structural stability

Referring to the diagram BUCKLING RESISTANCE UNDER PUSH LOAD for ILA . B Series on page 29, with PUSH LOAD 4500 N and STROKE 600 mm the selection of the actuator ILA 25 B is CORRECT.

7. Accessories and/or options selection

Select the actuator fixing attachments (see pages 192 ... 193), specify the input dimensions (see pages 192 ... 193) and/or other accessories and/or options (see pages 194 ... 195).

8. Check of actuator dimensions

Referring to actuator overall dimensions (see pages 192 ... 193), verify if the actuator dimensions fit to the application requirements .

9. Ordering code

Complete the ordering code of the selected actuator referring to the example on page 196.

SERVOMECH Linear Actuators

1.4 1st approximation selection diagrams

related to linear speed, dynamic load and THERMAL LIMIT

Acme screw linear actuators
ATL Series, size 20 ... 40

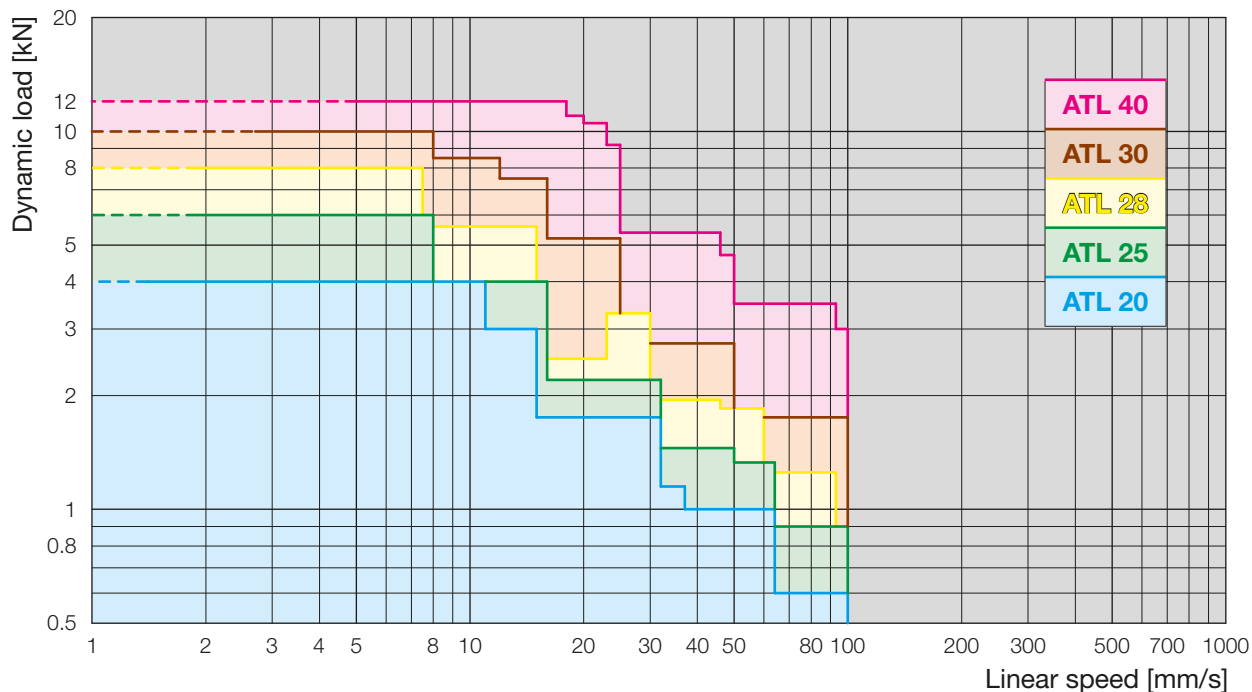

Acme screw linear actuators
ATL Series, size 50 ... 125

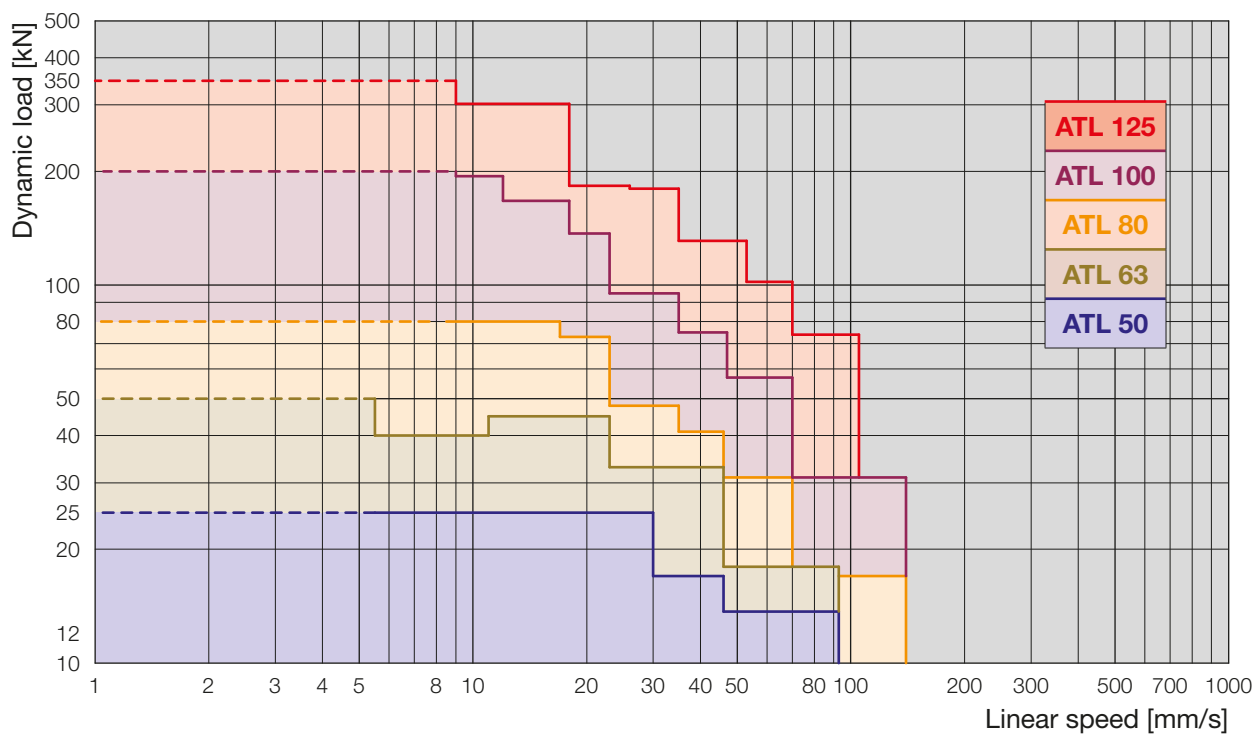

SERVOMECH Linear Actuators

1.4 1st approximation selection diagrams

related to linear speed, dynamic load and THERMAL LIMIT

1

Acme screw linear actuators
CLA Series

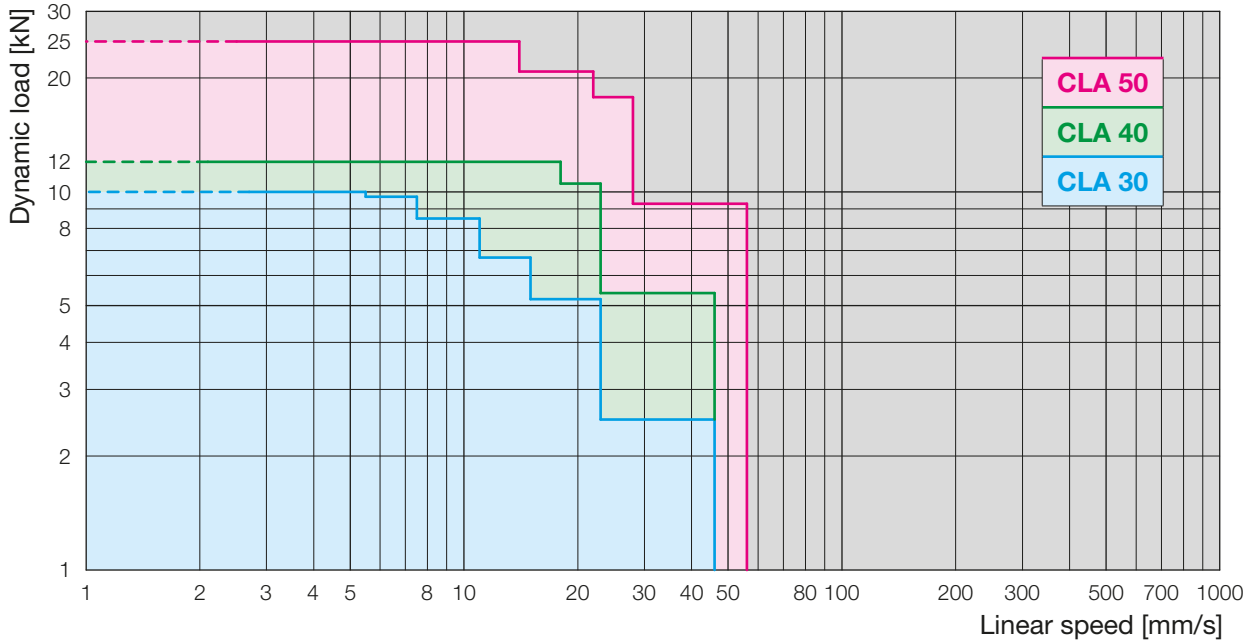

Acme screw linear actuators
UAL Series

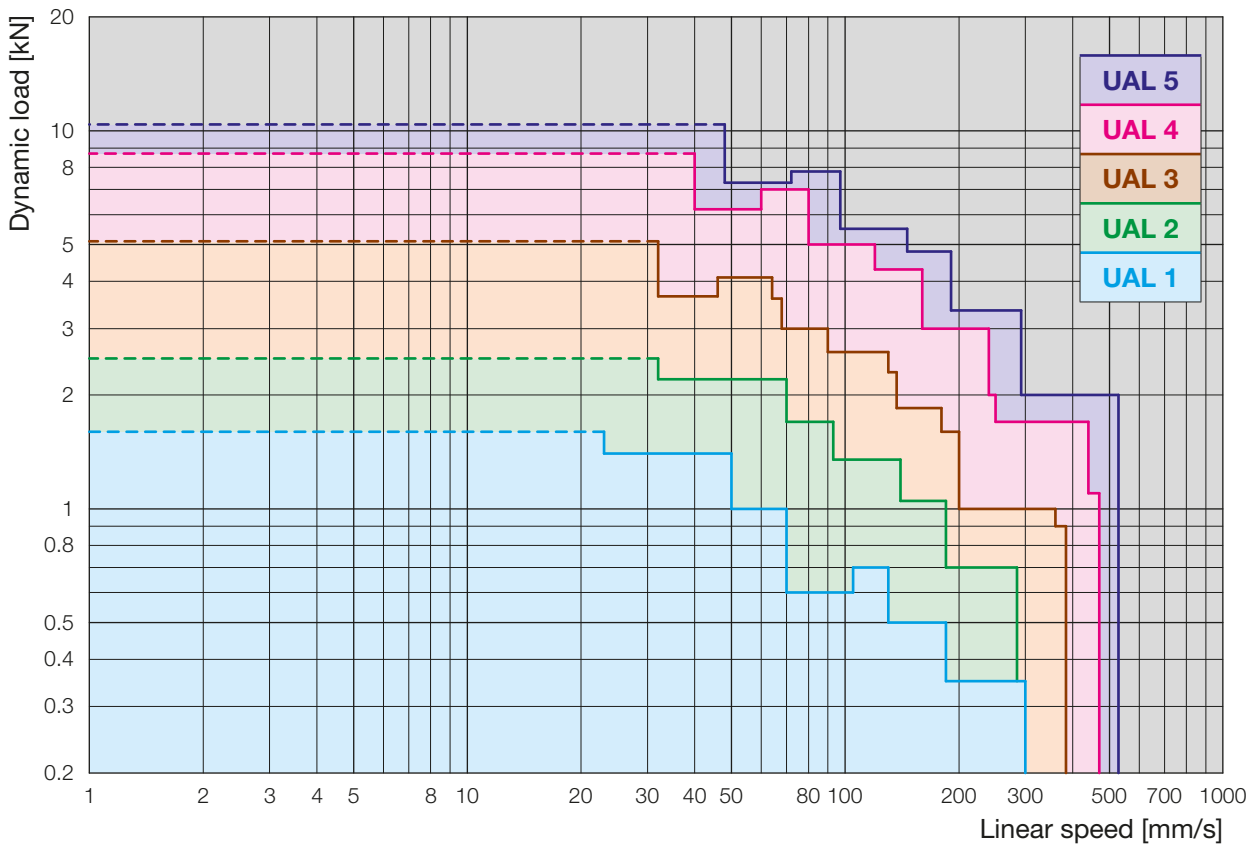

SERVOMECH Linear Actuators

1.4 1st approximation selection diagrams

related to linear speed, dynamic load and THERMAL LIMIT



Acme screw linear actuators
TMA Series

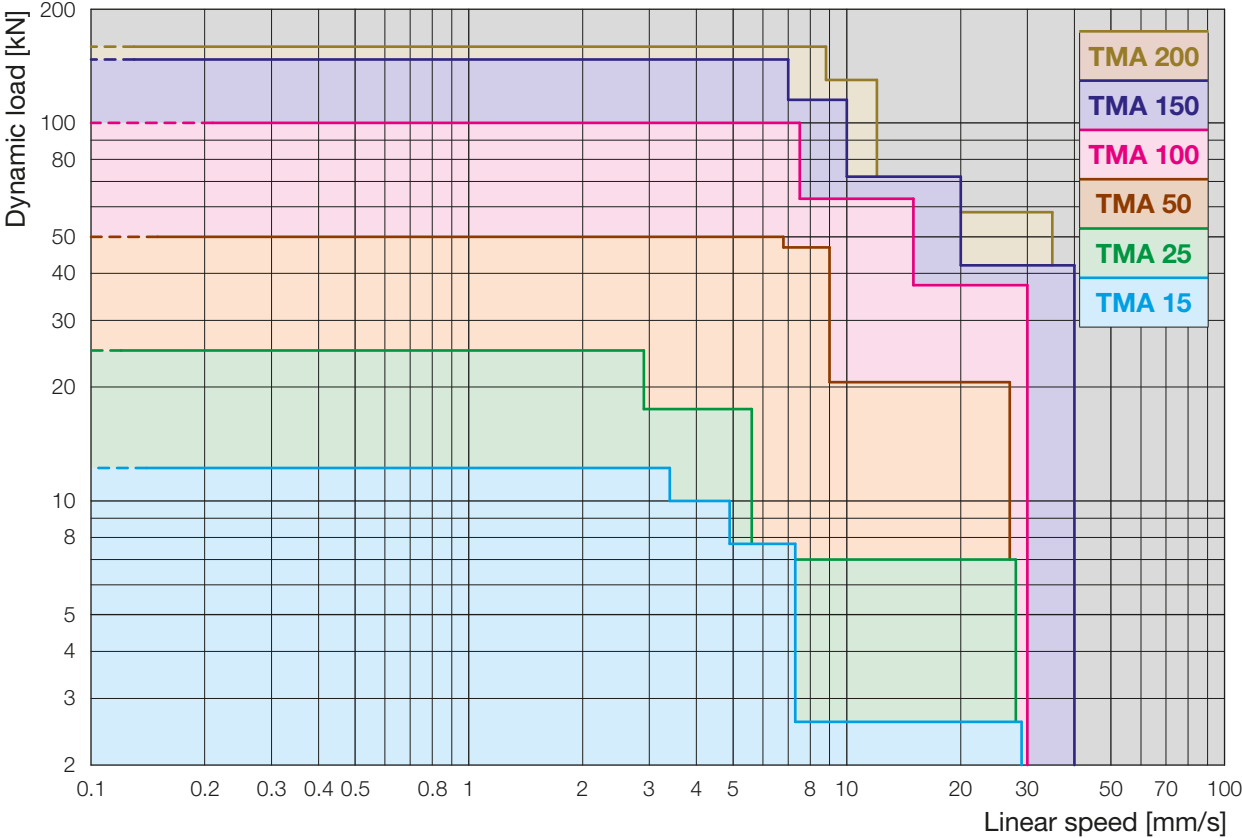

SERVOMECH Linear Actuators

1.4 1st approximation selection diagrams

related to linear speed, dynamic load and THERMAL LIMIT

Acme screw linear actuators
ILA 15 A ... ILA 50 A

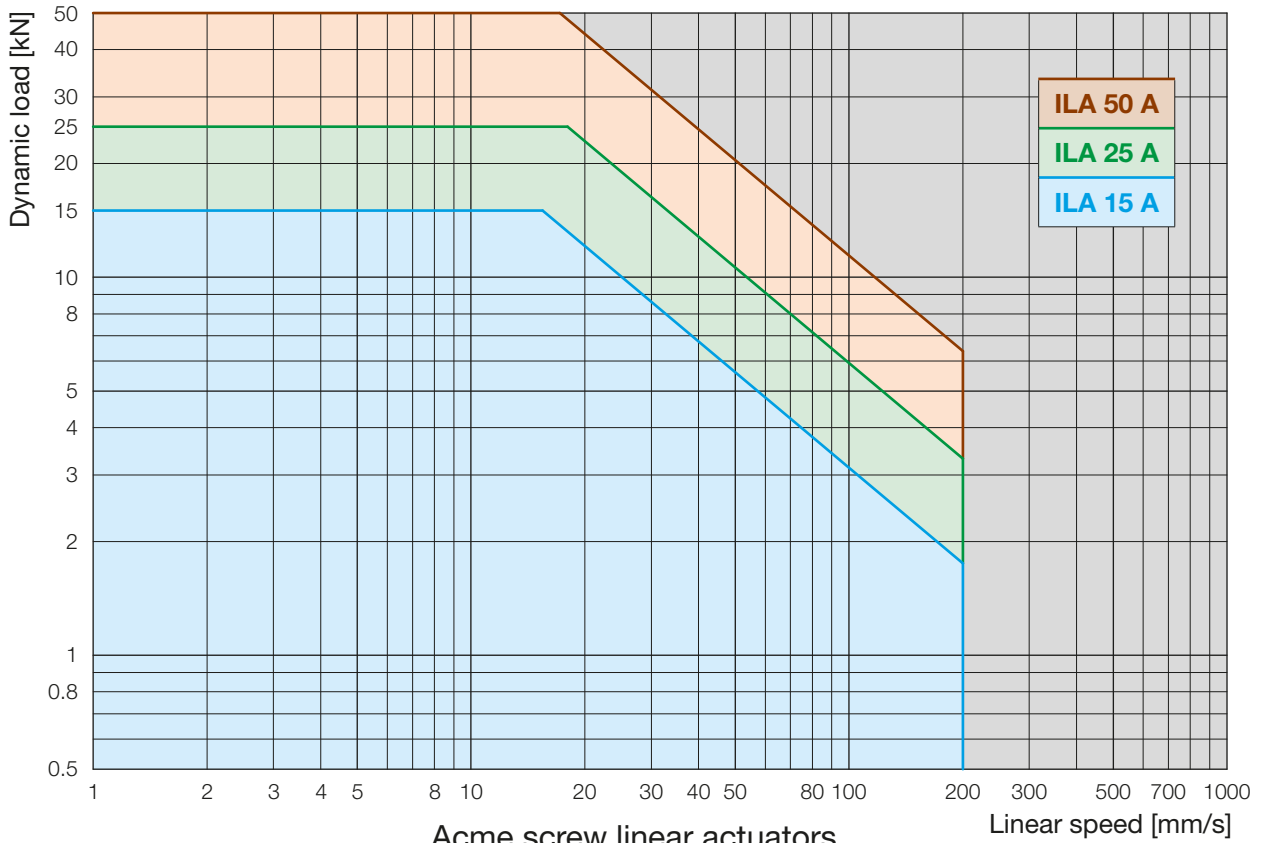

Acme screw linear actuators
ILA 100 A ... ILA 200 A

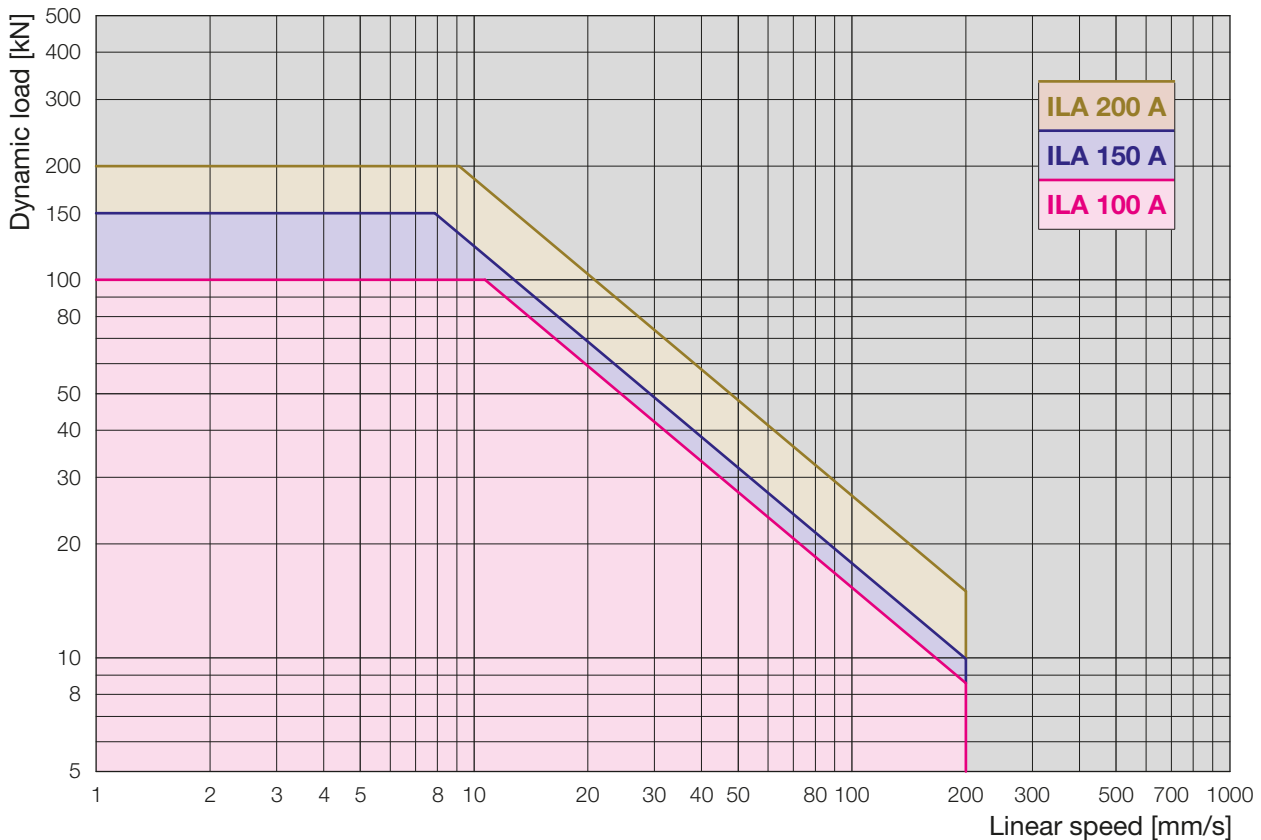

SERVOMECH Linear Actuators

1.4 1st approximation selection diagrams

related to linear speed, dynamic load and ball screw load capacity

Ball screw linear actuators
BSA Series, size 20 ... 40

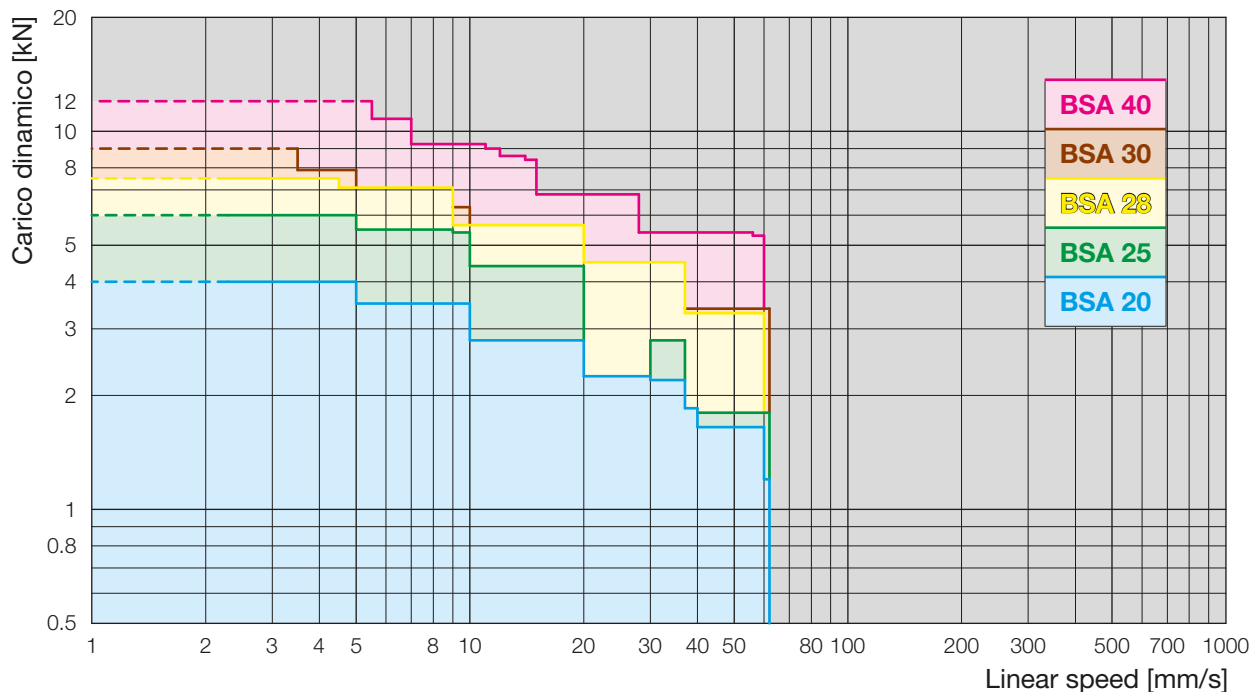

Ball screw linear actuators
BSA Series, size 50 ... 125

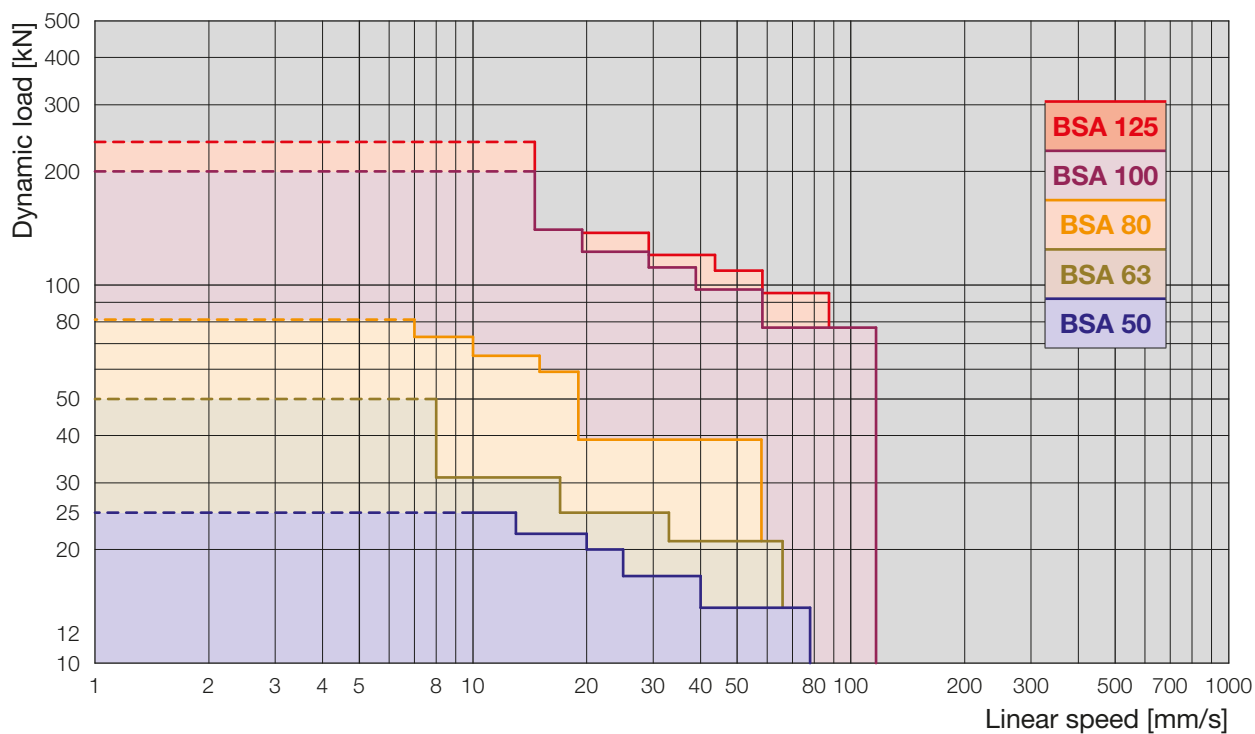

SERVOMECH Linear Actuators

1.4 1st approximation selection diagrams

related to linear speed, dynamic load and ball screw load capacity

1

Ball screw linear actuators
CLB Series

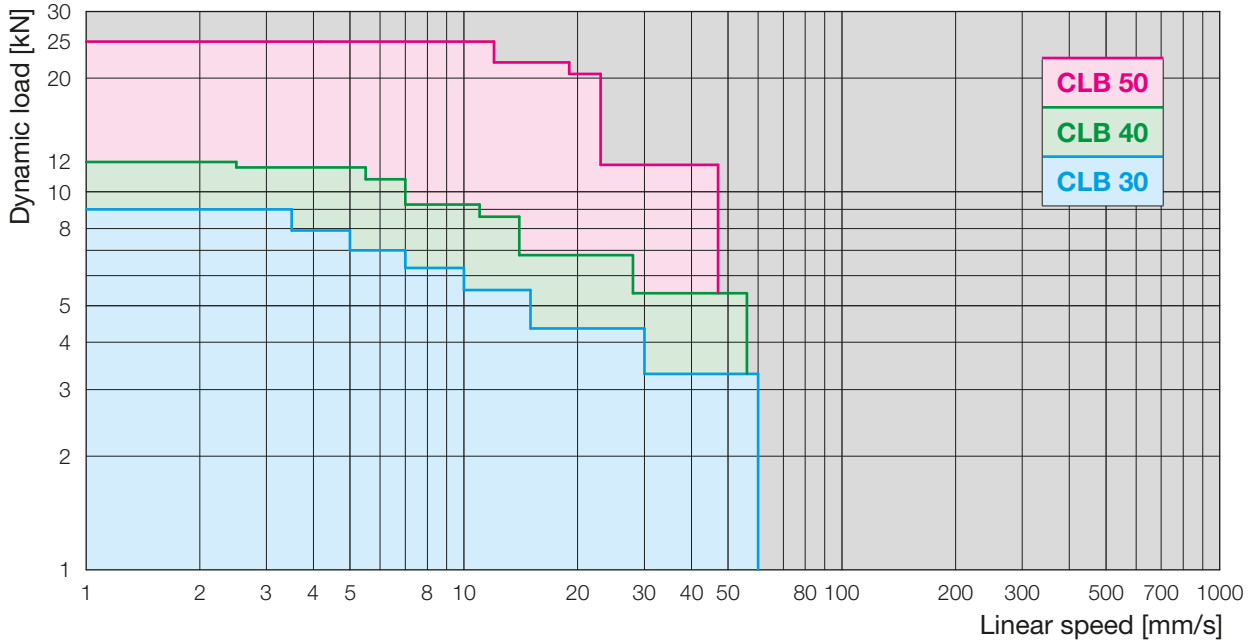

Ball screw linear actuators
UBA Series

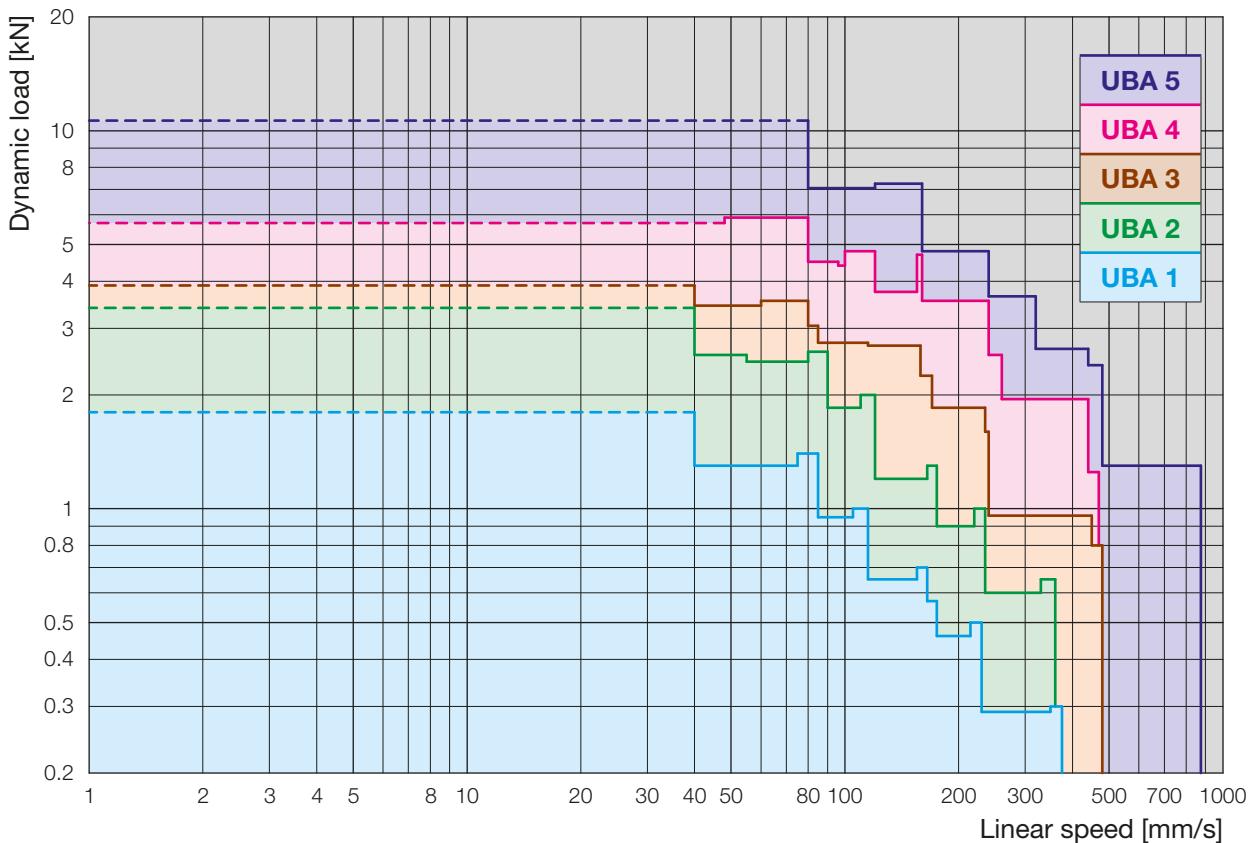

SERVOMECH Linear Actuators

1.5 Buckling resistance under push load - Euler III diagrams

Acme screw linear actuators **ATL Series**

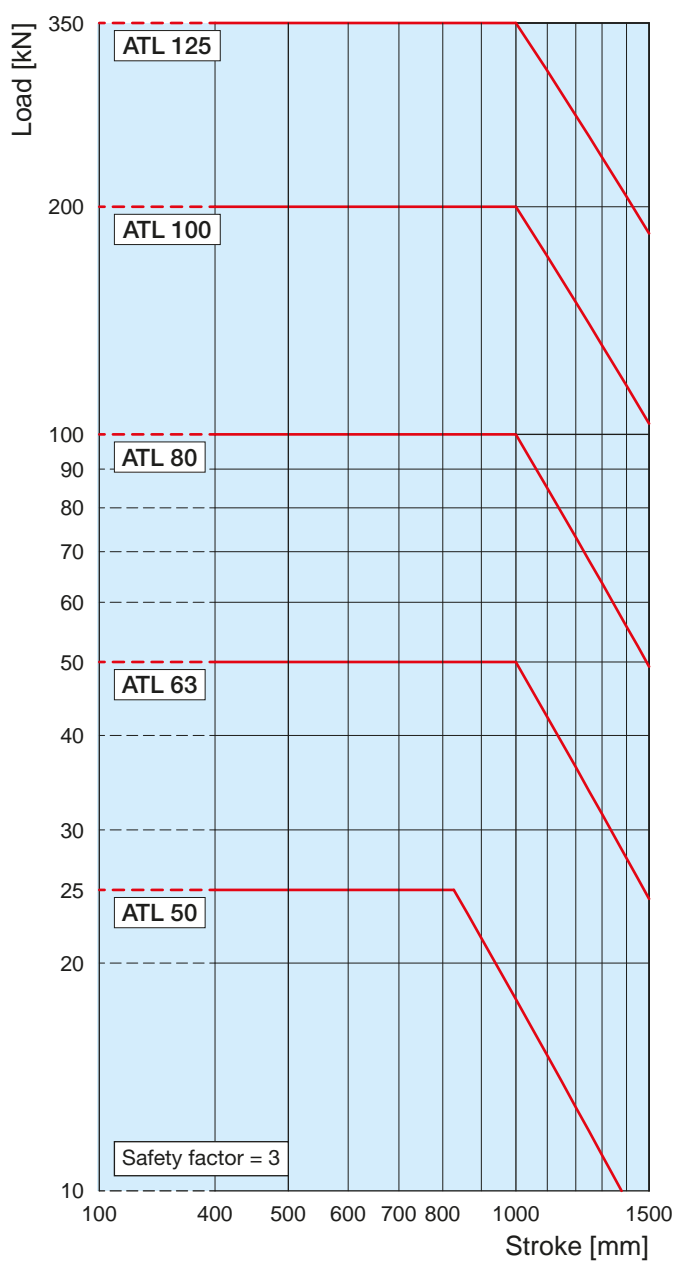
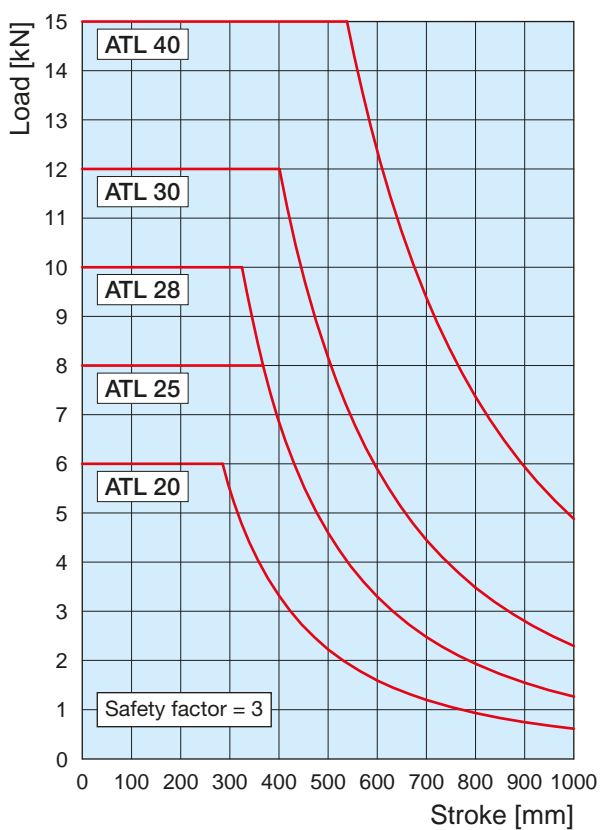
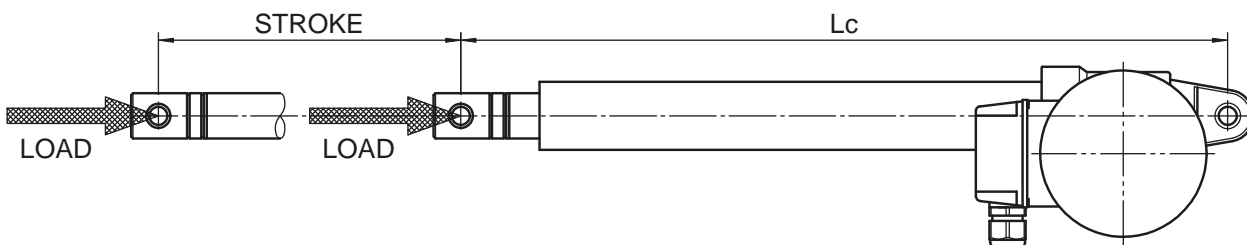

SERVOMECH Linear Actuators

1.5 Buckling resistance under push load - Euler III diagrams Ball screw linear actuators BSA Series

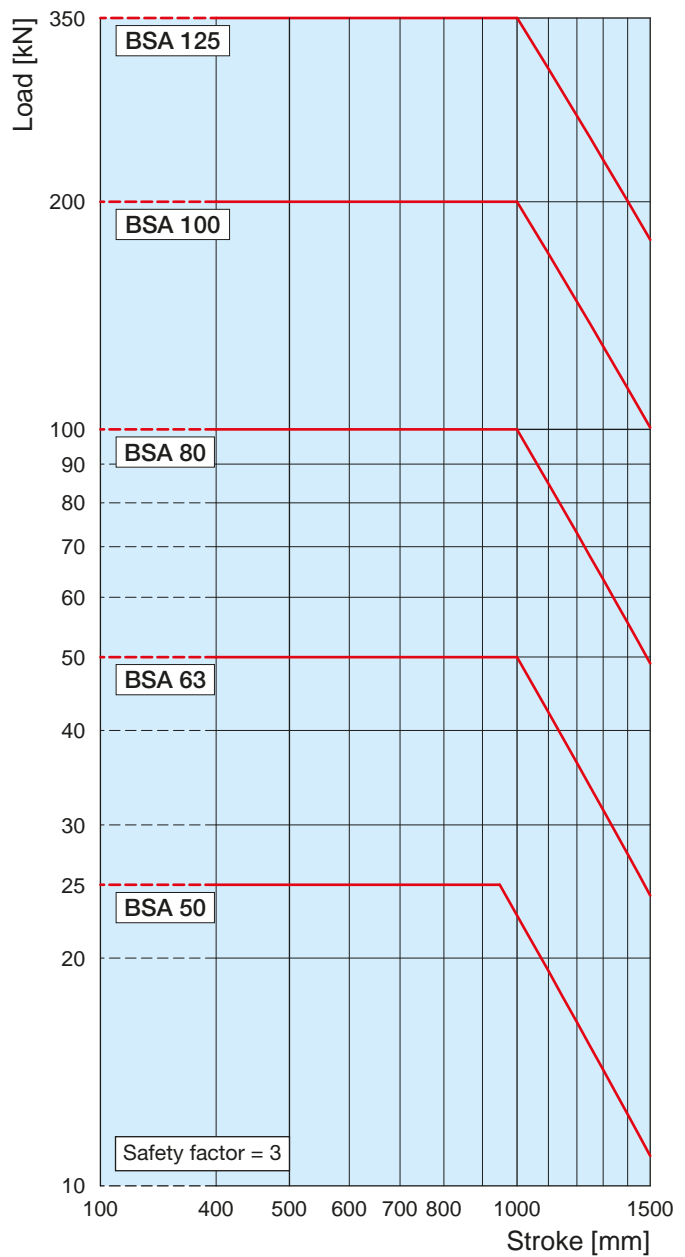
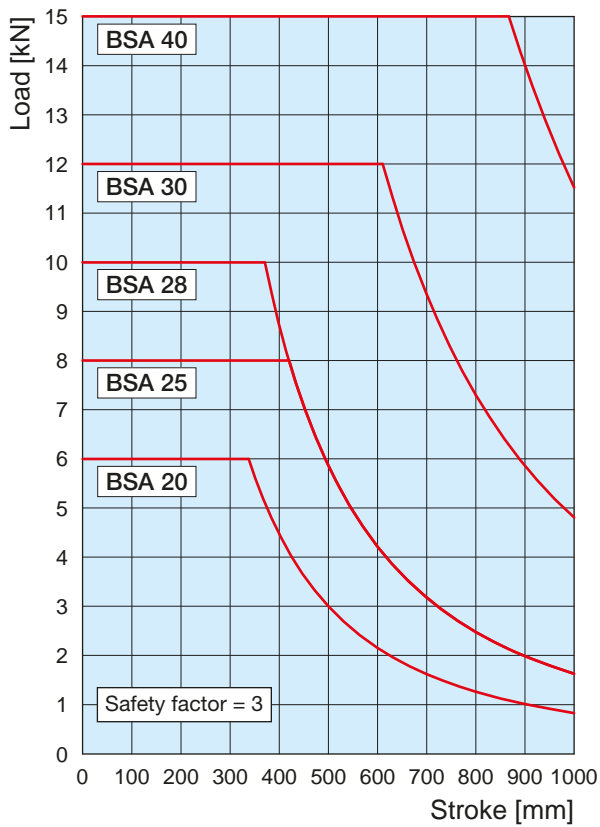
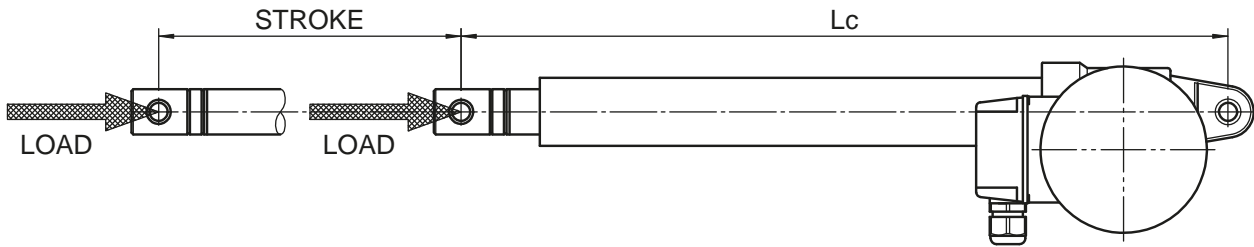

SERVOMECH Linear Actuators

1.5 Buckling resistance under push load - Euler III diagrams

Acme screw linear actuators **CLA Series**

Ball screw linear actuators **CLB Series**

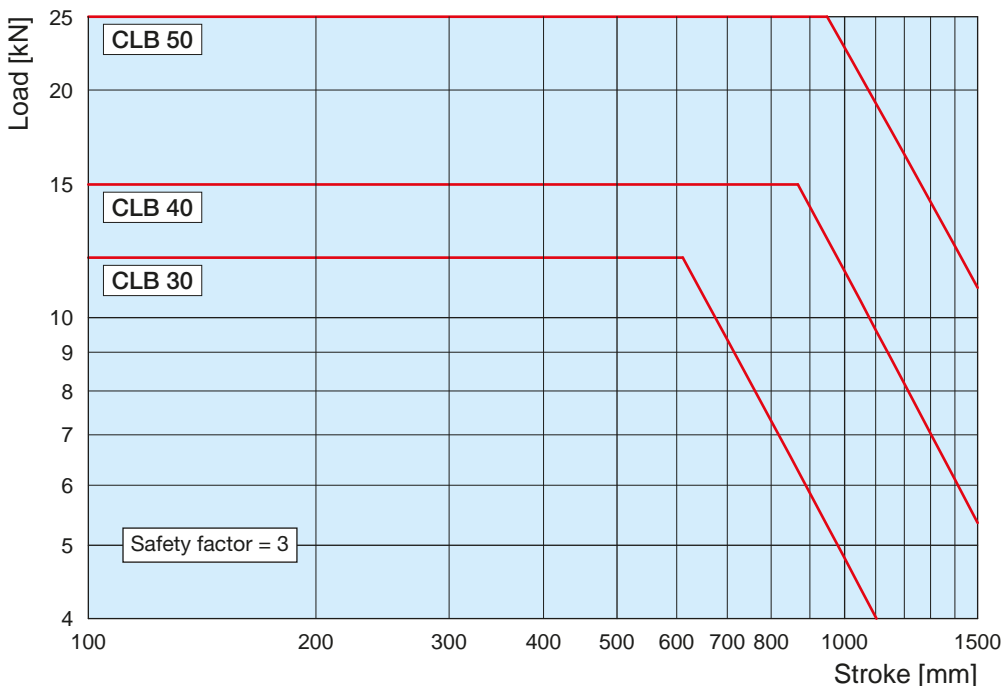
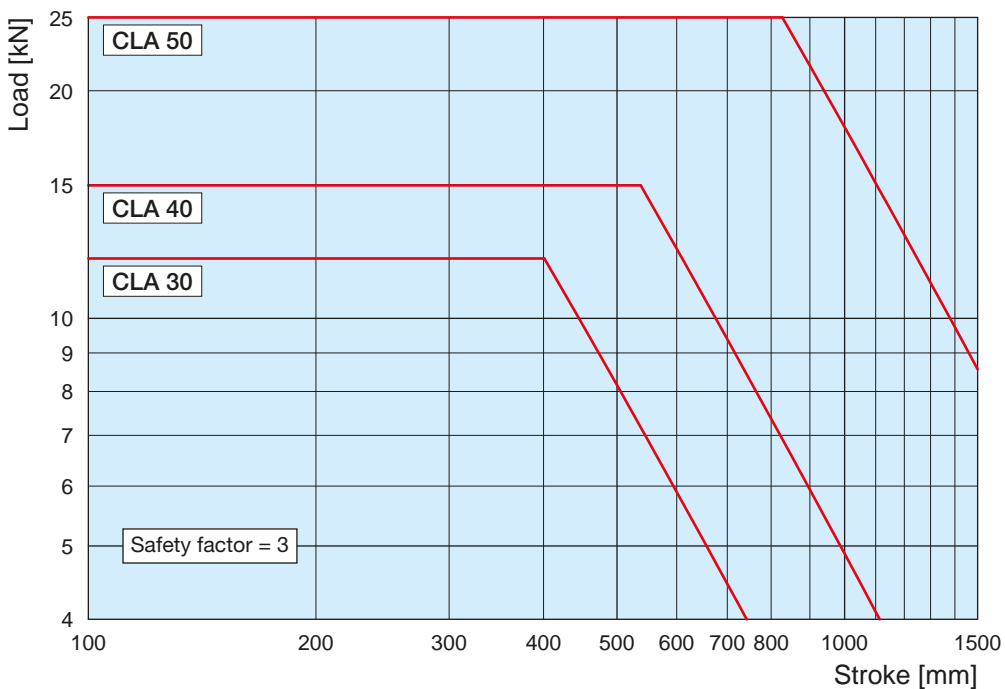
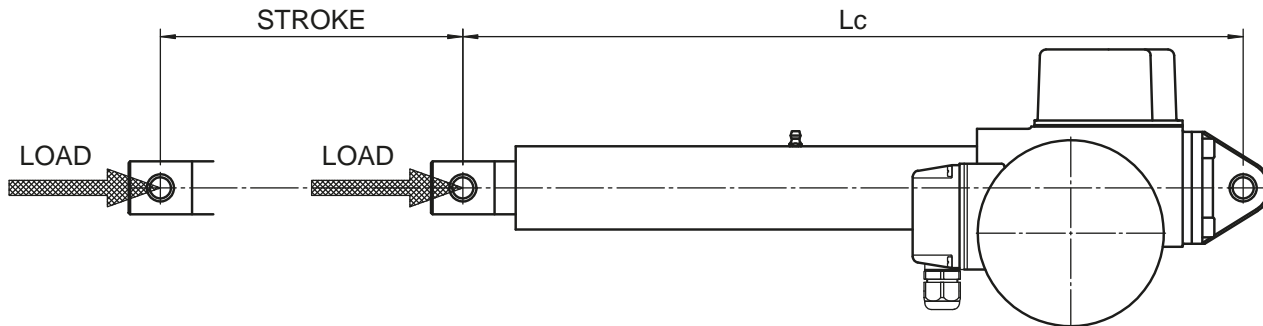

SERVOMECH Linear Actuators

1.5 Buckling resistance under push load - Euler III diagrams

Acme screw linear actuators **UAL Series**

Ball screw linear actuators **UBA Series**

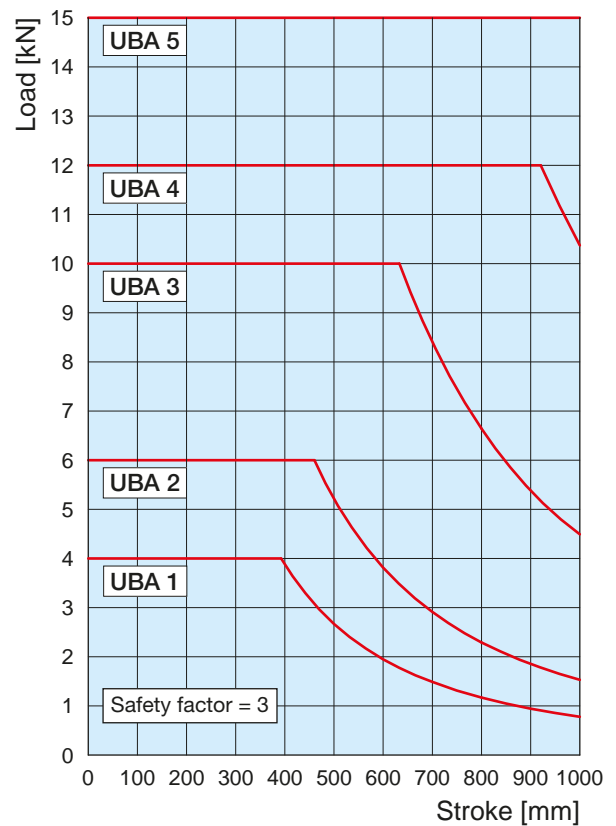
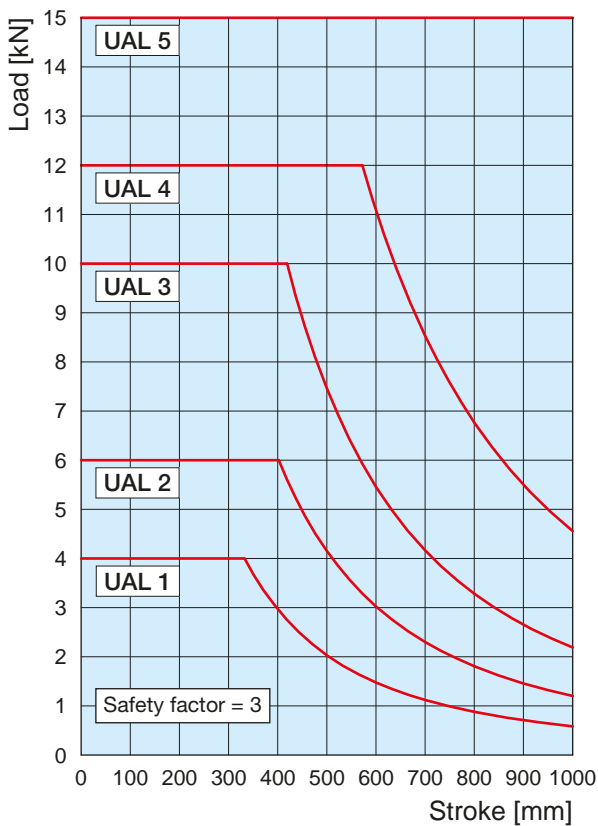
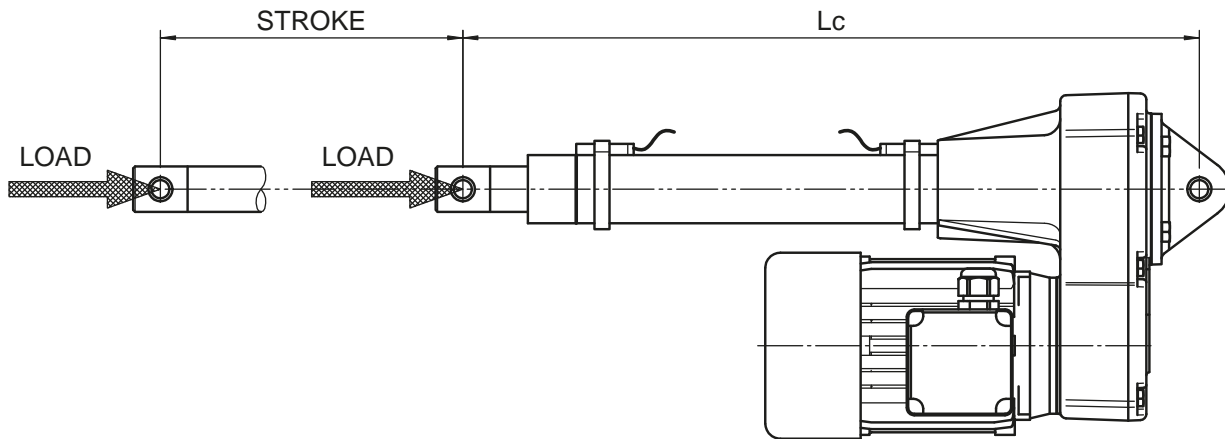

SERVOMECH Linear Actuators

1.5 Buckling resistance under push load - Euler II diagrams

Acme screw linear actuators **TMA Series**

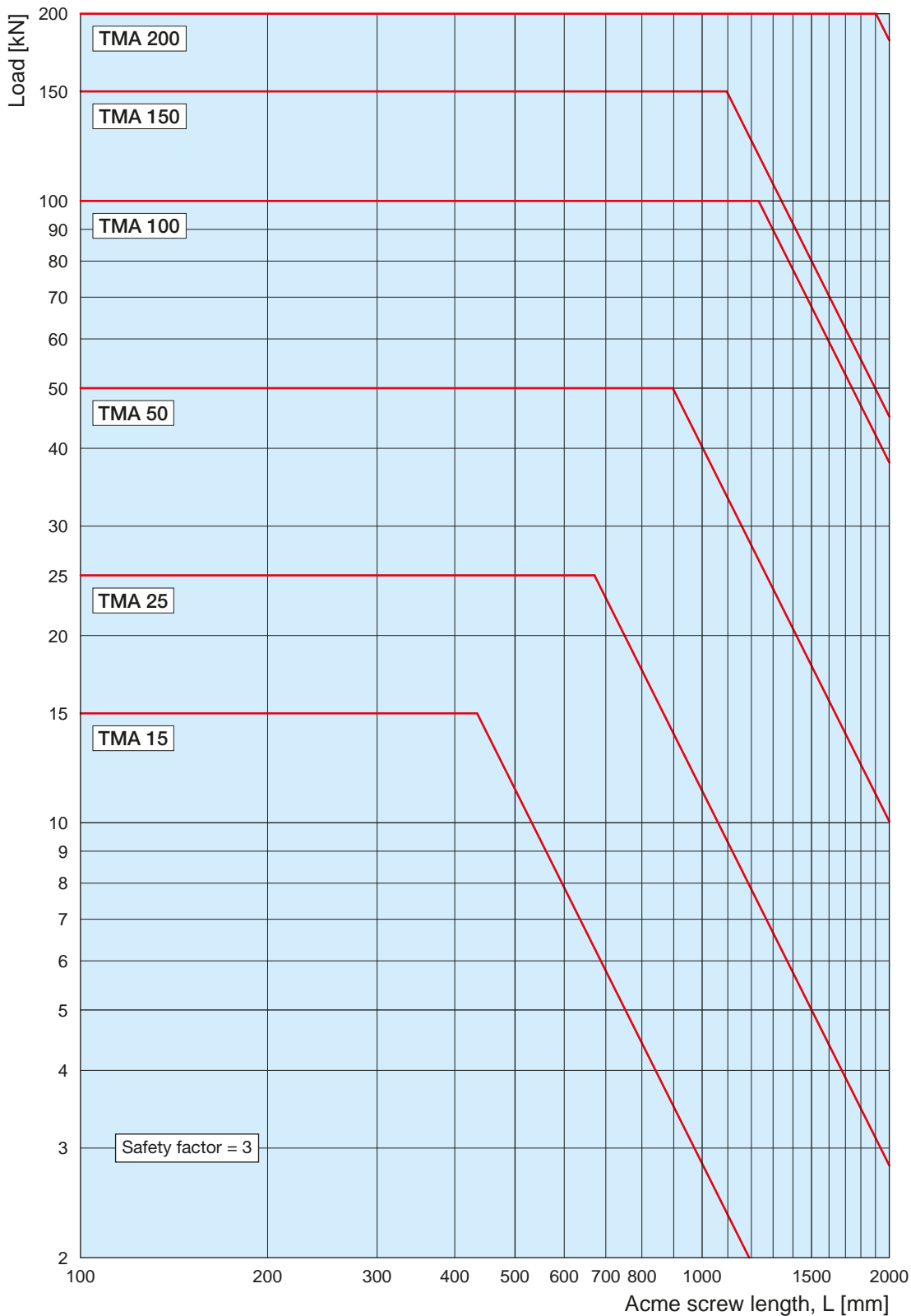
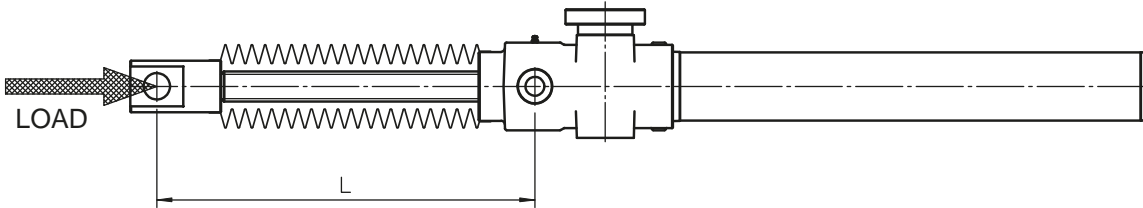

SERVOMECH Linear Actuators

1.5 Buckling resistance under push load - Euler III diagrams

Acme screw linear actuators **ILA . A Series**

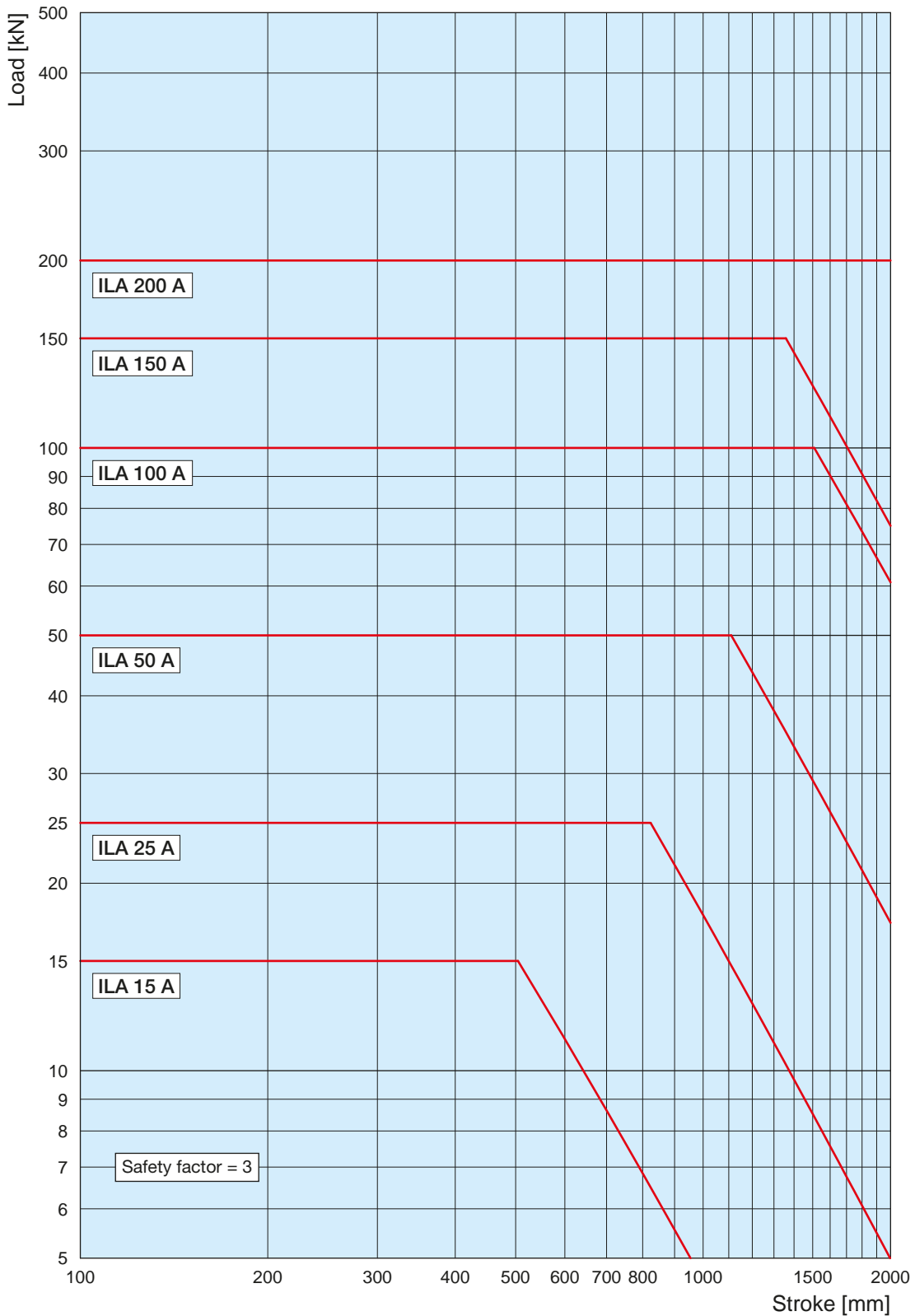
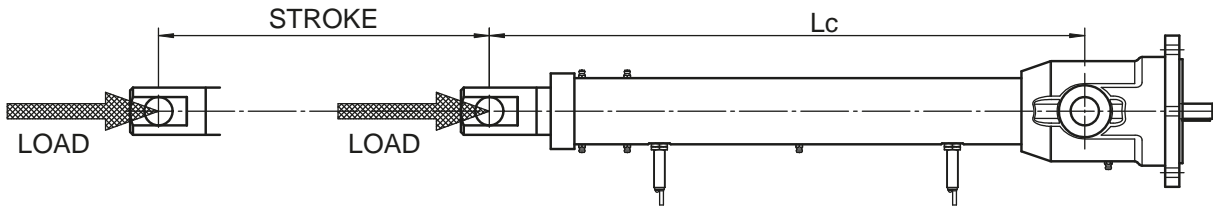

SERVOMECH Linear Actuators

1.5 Buckling resistance under push load - Euler III diagrams

Ball screw linear actuators **ILA . B Series**

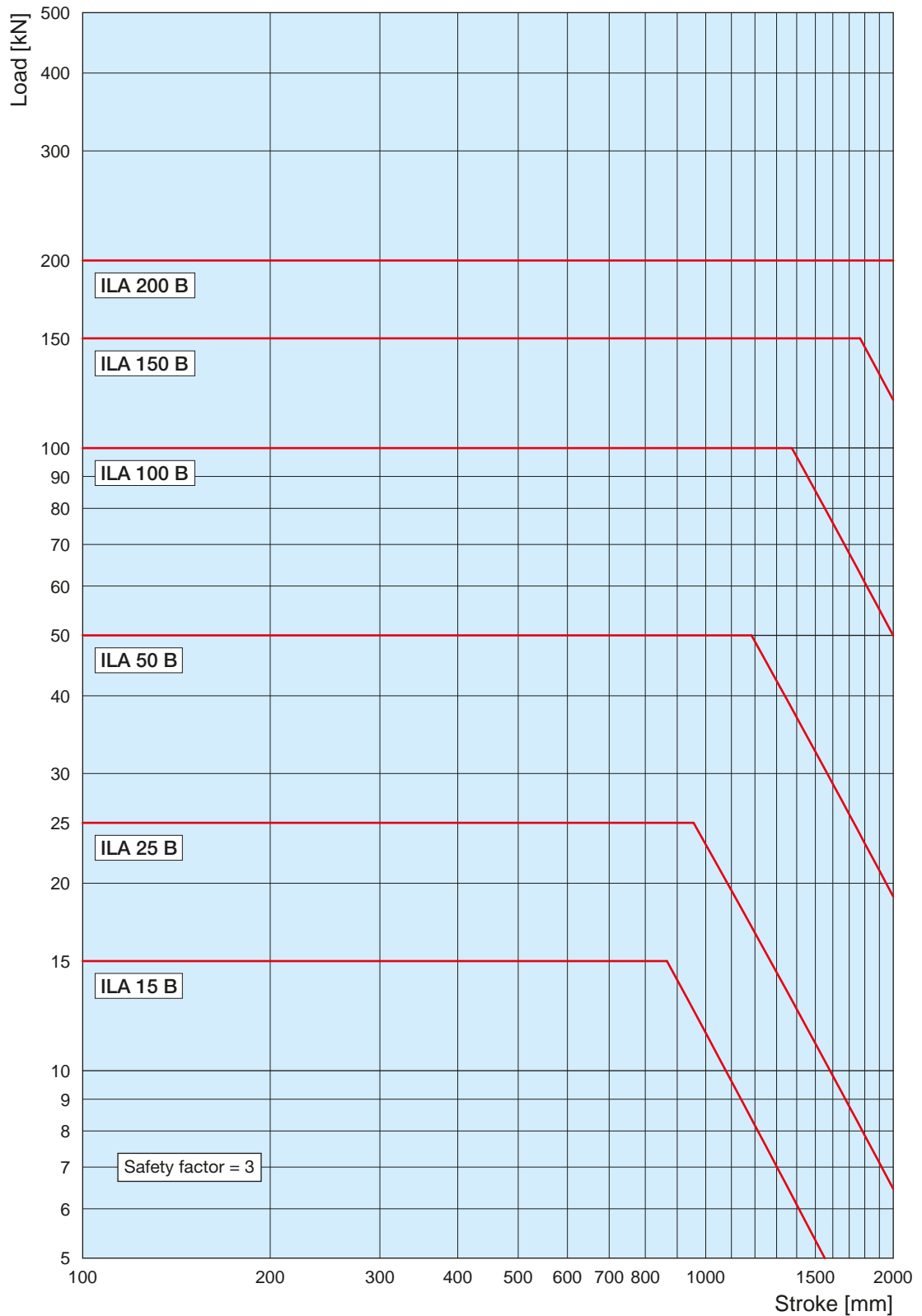
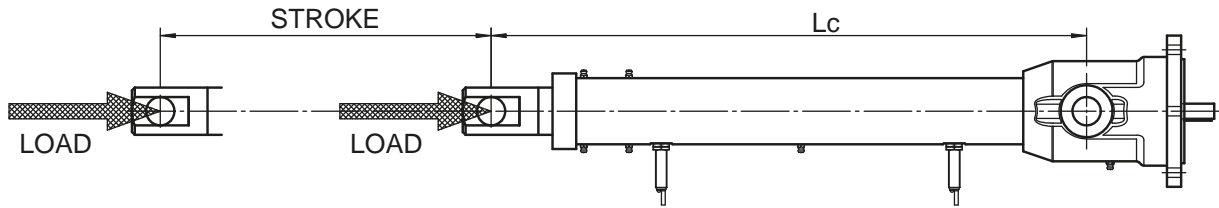

1.6 Ball screw lifetime – performed stroke related to load

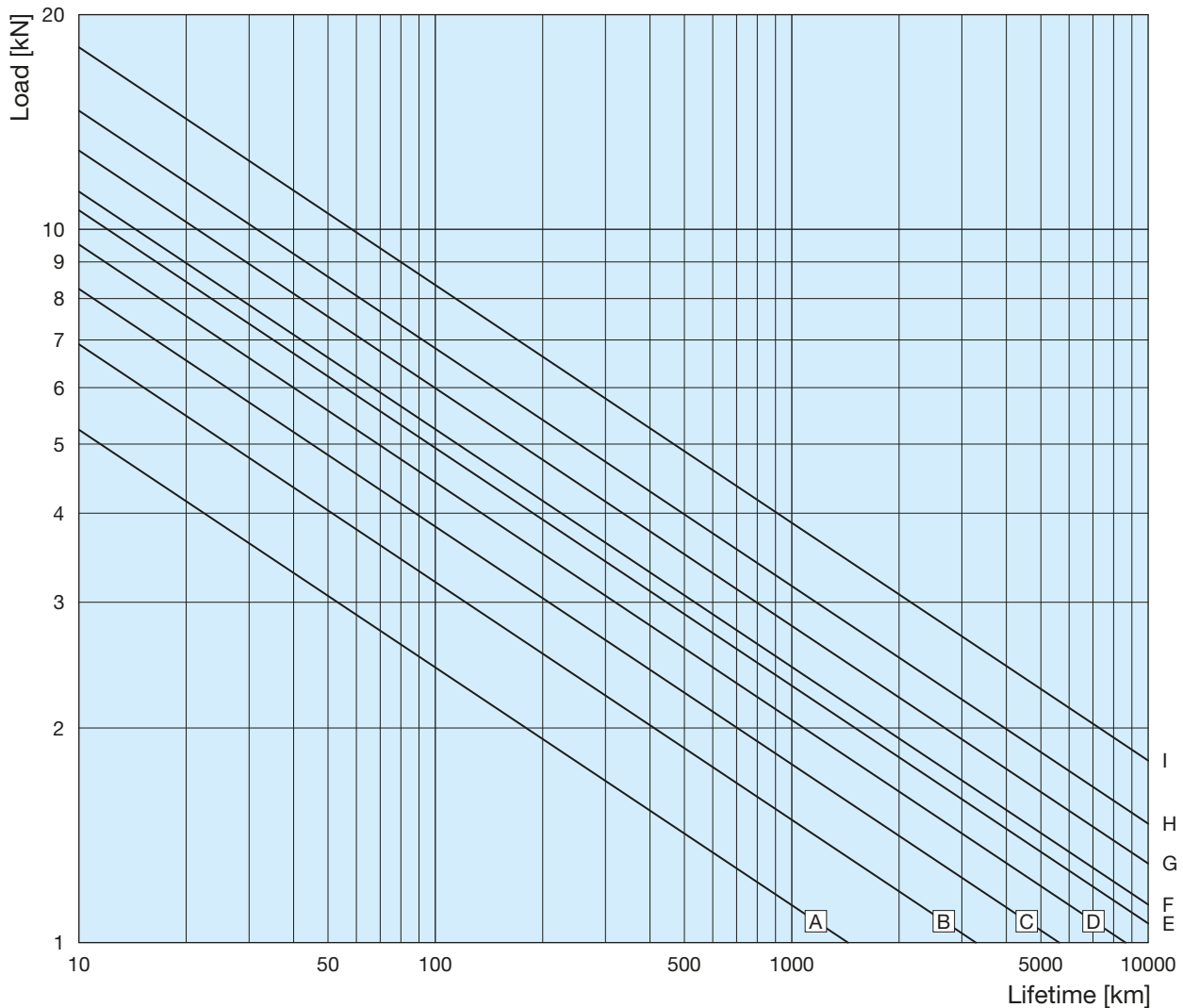

BALL SCREW	ball [mm]	n° of circuits	C_a [kN]	C_{0a} [kN]	CURVE
BS 14x5	3.175	2	6.6	8.6	A
BS 14x10	3.175	2	6.9	9.3	B
BS 16x5	3.175	3	10.4	15.6	C
BS 16x5	3.175	4	13.4	20.9	E
BS 16x10	3.175	3	11.3	18	F
BS 20x5	3.175	3	12	21.2	D
BS 20x10	3.175	3	12.9	23.5	G
BS 25x6	3.969	3	17.4	30.5	H
BS 25x10	3.969	3	18	33	I

SERVOMECH Linear Actuators



1.6 Ball screw lifetime – performed stroke related to load

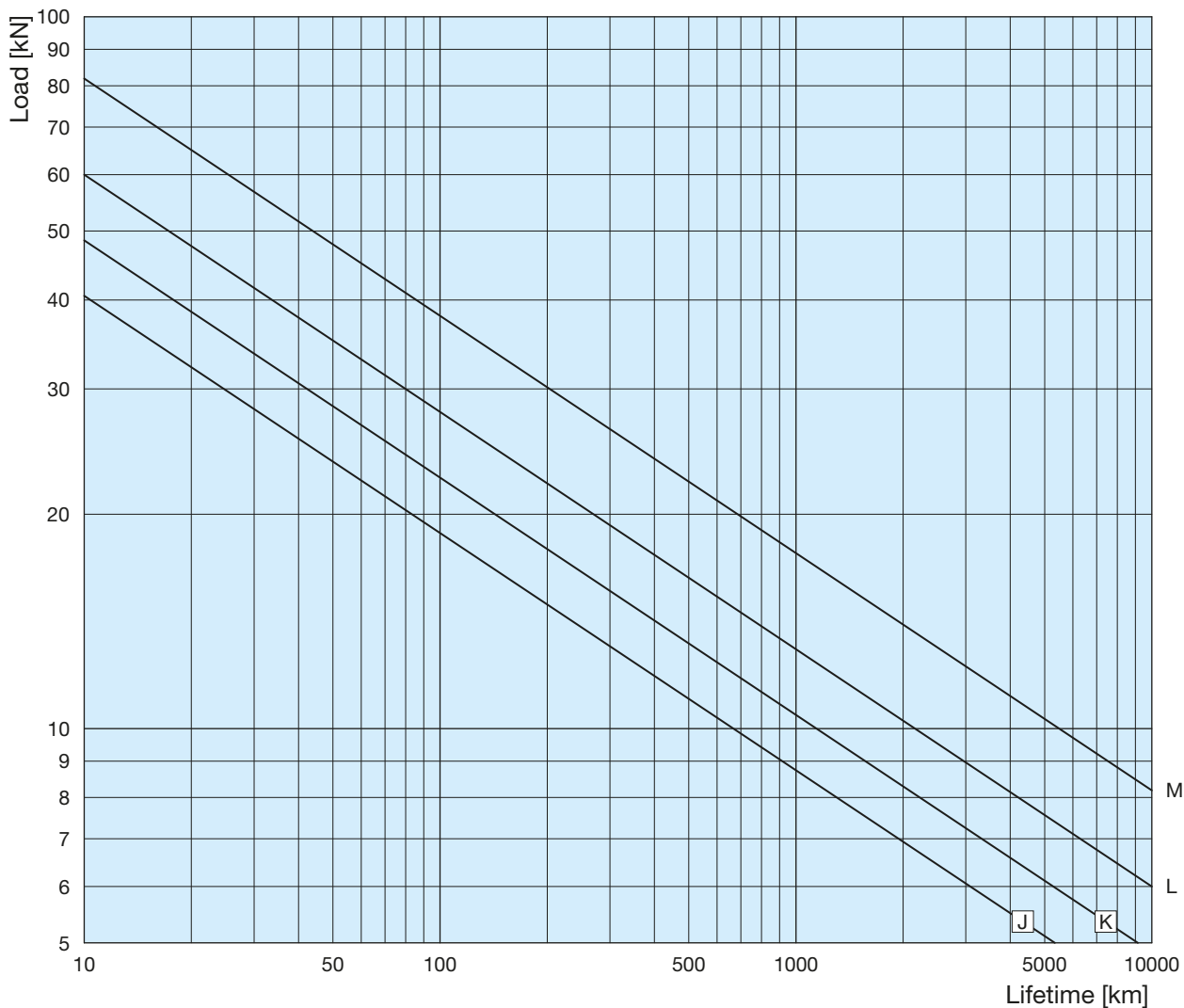

BALL SCREW	ball [mm]	n° of circuits	C_a [kN]	C_{0a} [kN]	CURVE
BS 32×10	6.35	4	41.8	73	J
BS 32×20	6.35	3	32.2	53	J
BS 40×10	6.35	5	60	123	L
BS 40×20	6.35	3	38.5	74	K
BS 50×10	6.35	5	83	188	M
BS 50×20	6.35	4	65	140	M

1.6 Ball screw lifetime – performed stroke related to load

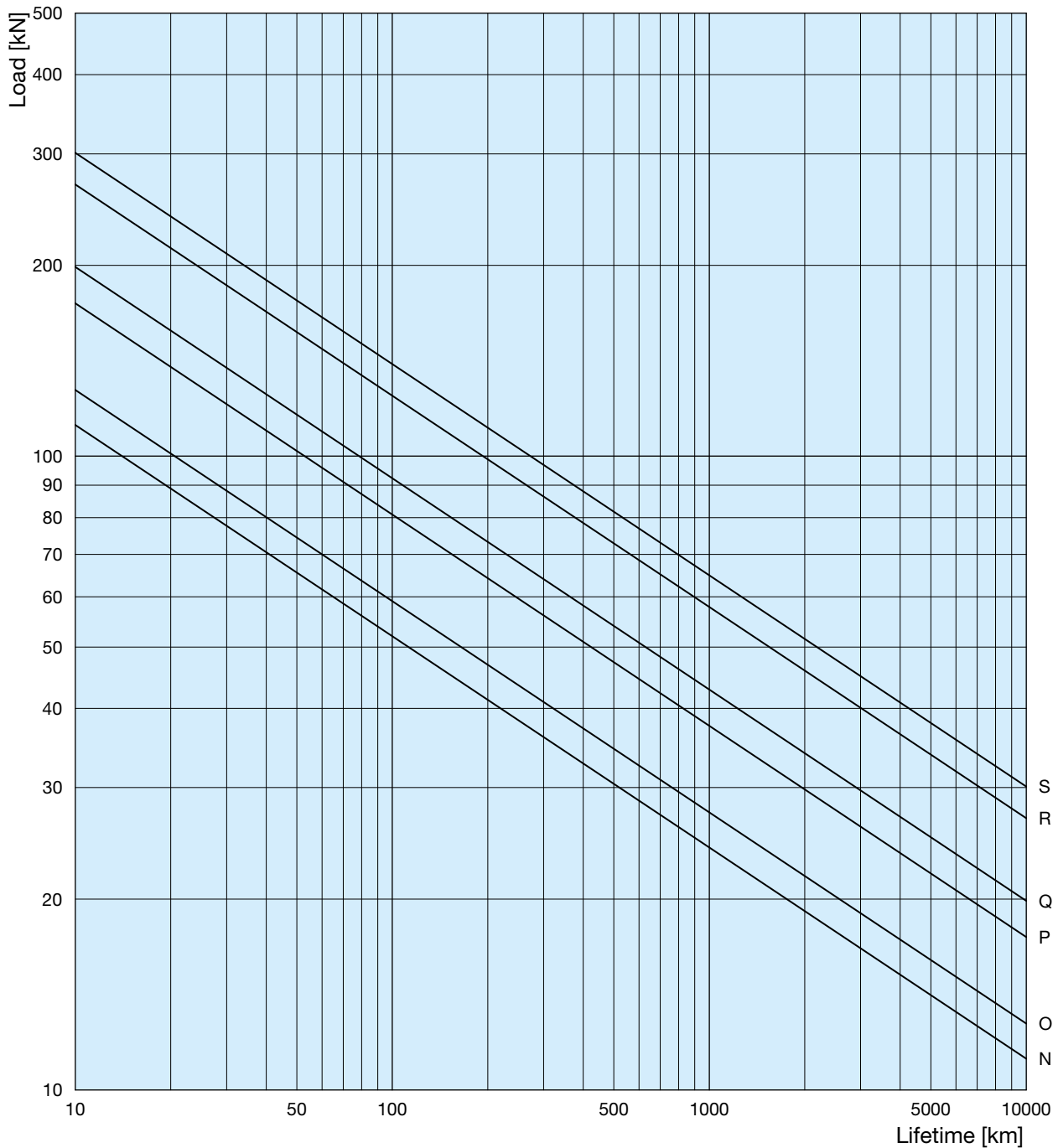

BALL SCREW	ball [mm]	n° of circuits	C _a [kN]	C _{0a} [kN]	CURVE
BS 63×10	7.144	6	112	313	N
BS 63×20	9.525	4	101	220	O
BS 80×16	9.525	5	149	393	P
BS 80×20	12.7	4	213	516	R
BS 100×16	9.525	5	170	523	Q
BS 100×20	12.7	4	239	687	S

SERVOMECH Linear Actuators

1.7 Ball screw lifetime related to load and linear speed

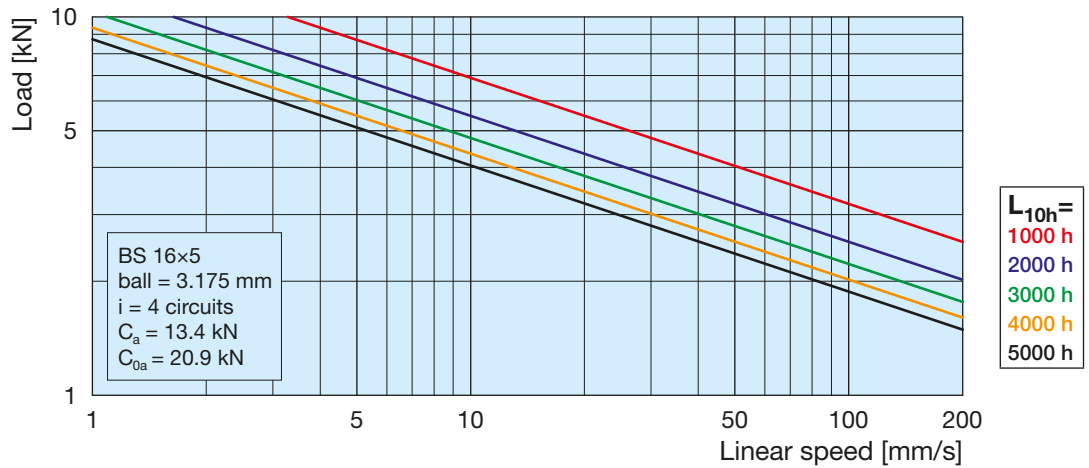
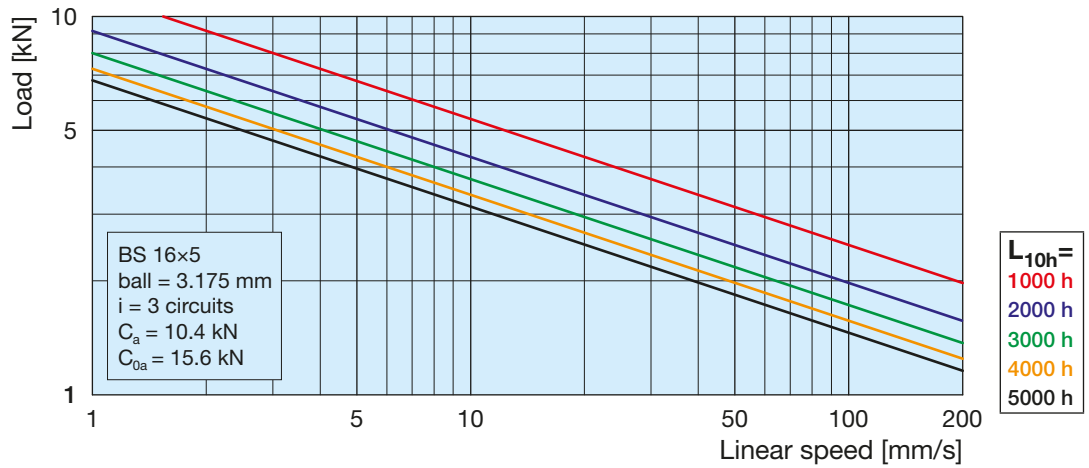
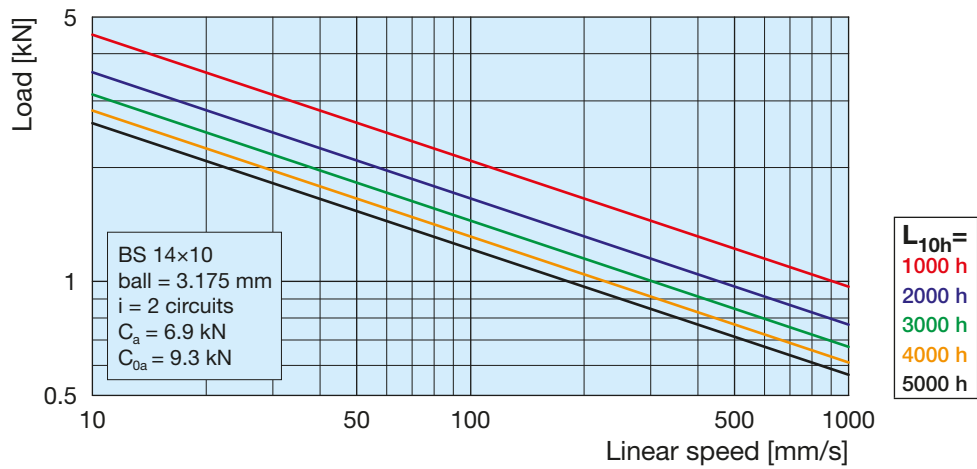
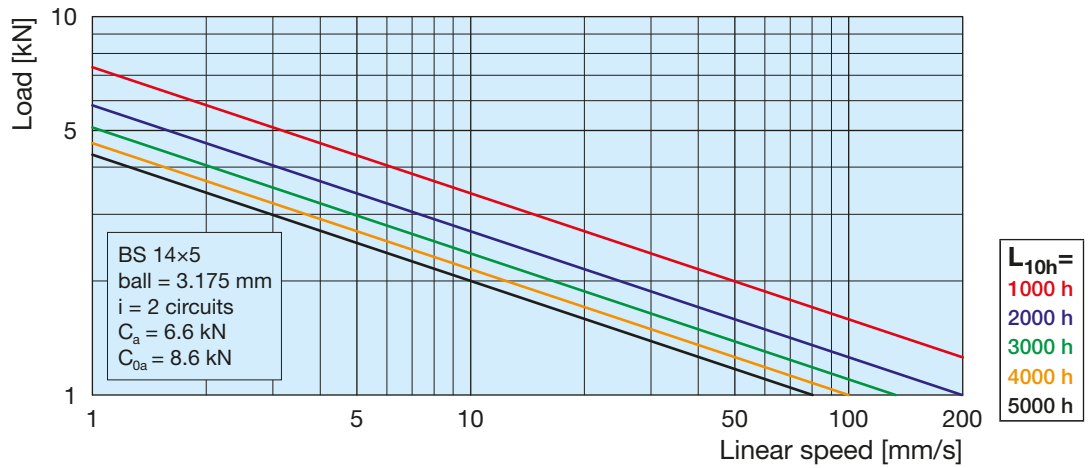

SERVOMECH Linear Actuators

1.7 Ball screw lifetime related to load and linear speed

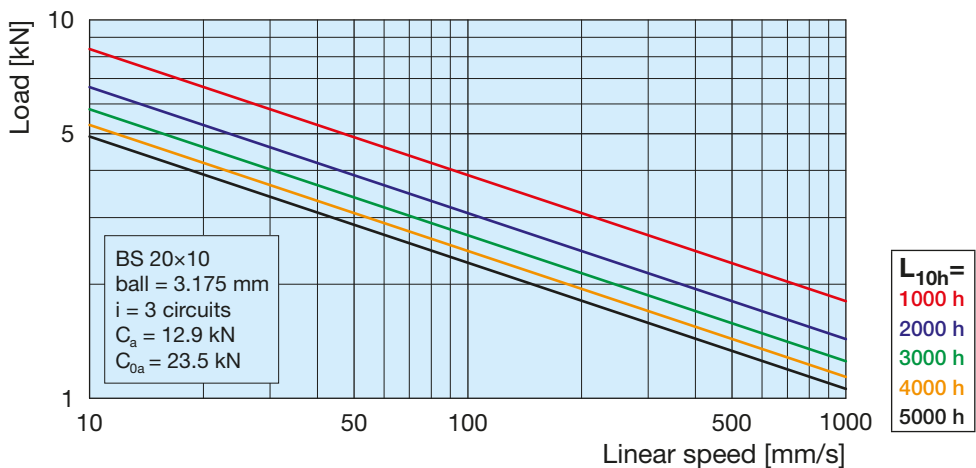
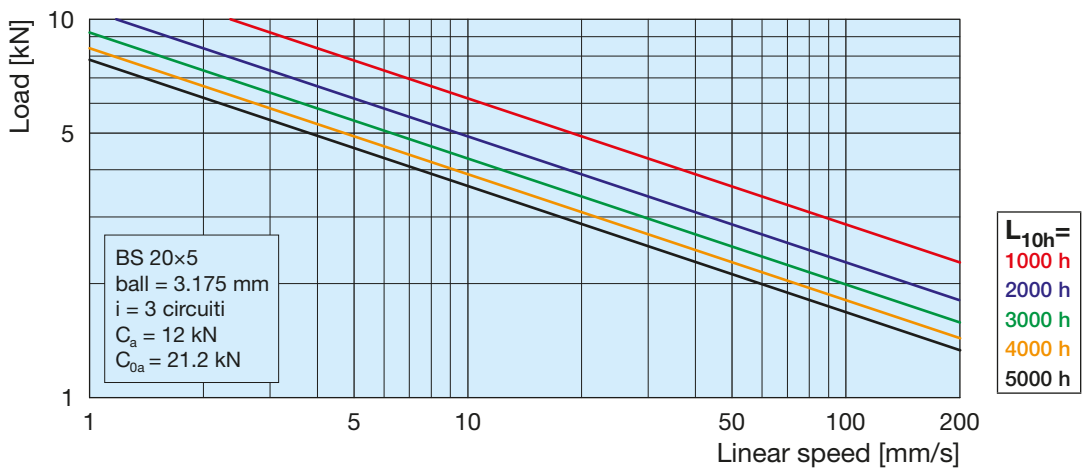
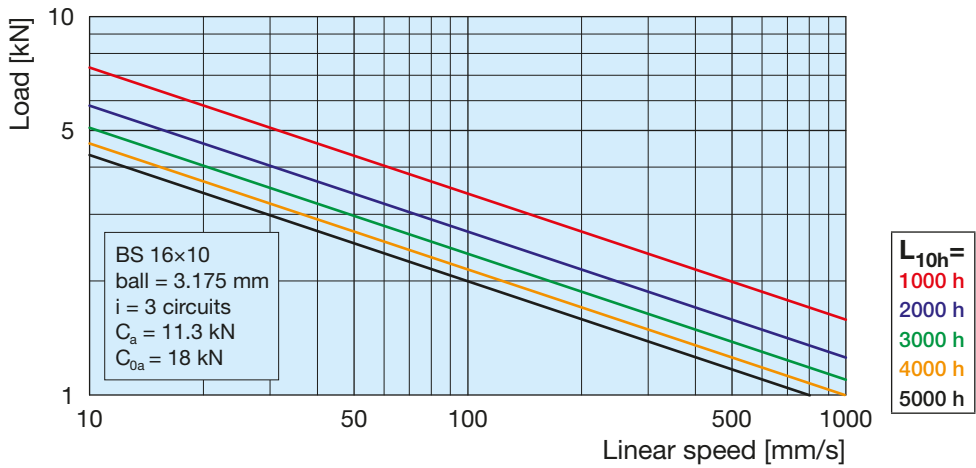

SERVOMECH Linear Actuators

1.7 Ball screw lifetime related to load and linear speed

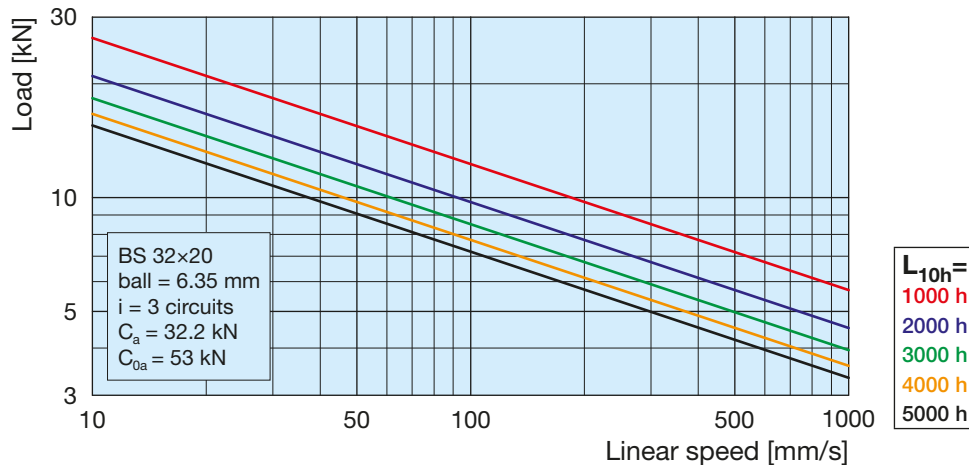
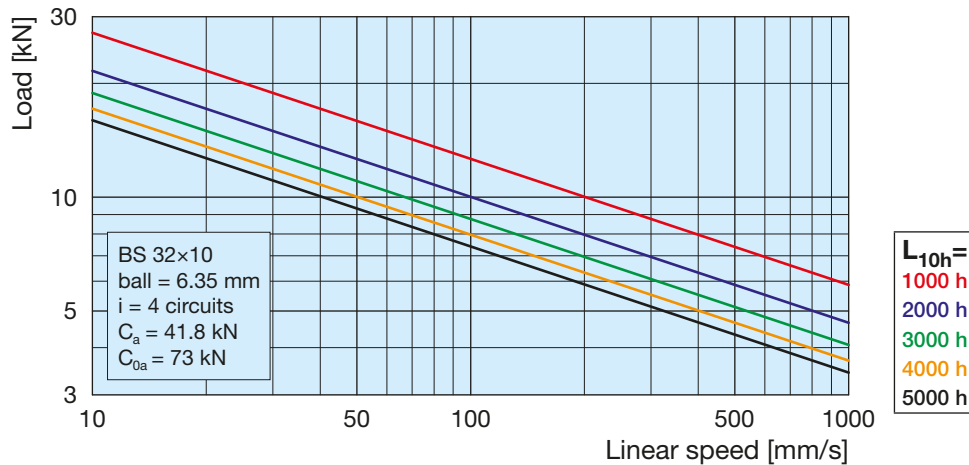
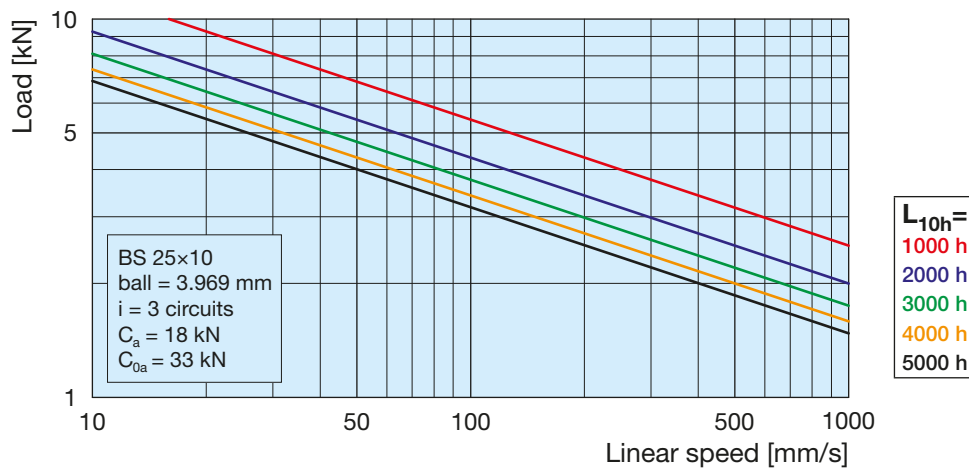
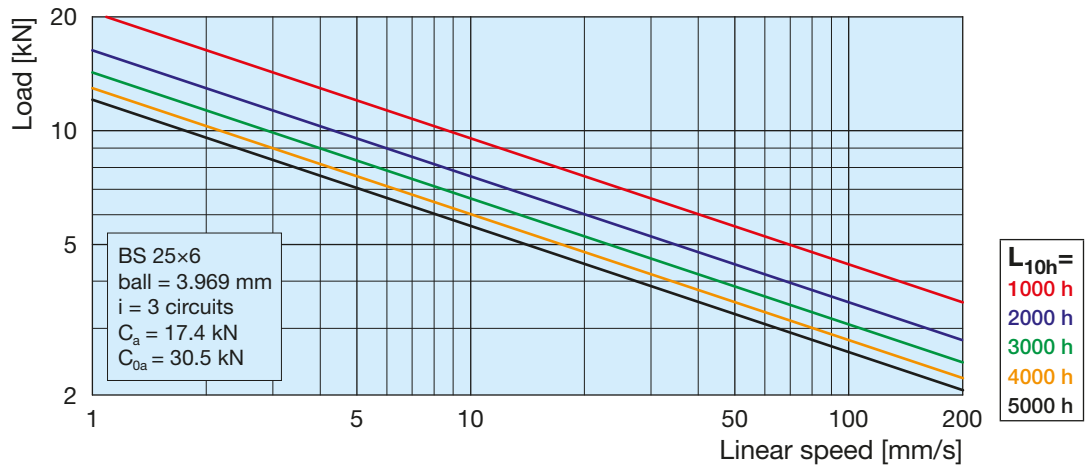

SERVOMECH Linear Actuators

1.7 Ball screw lifetime related to load and linear speed

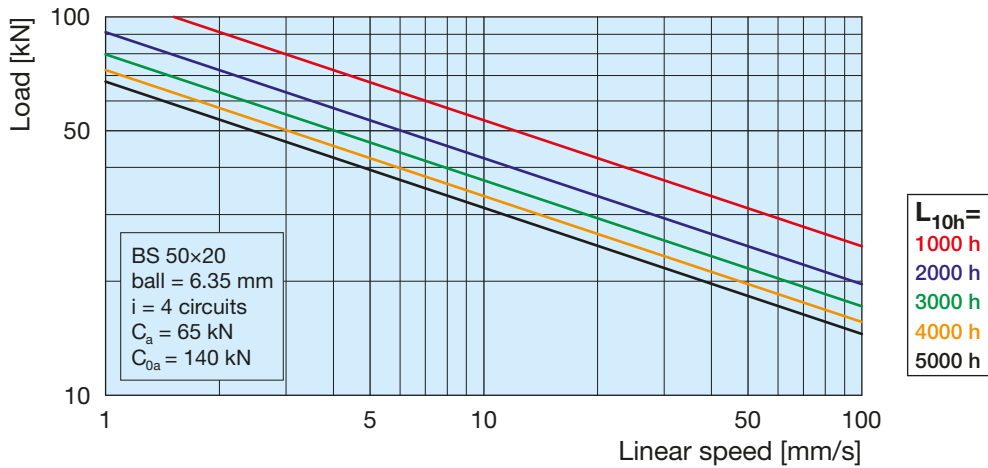
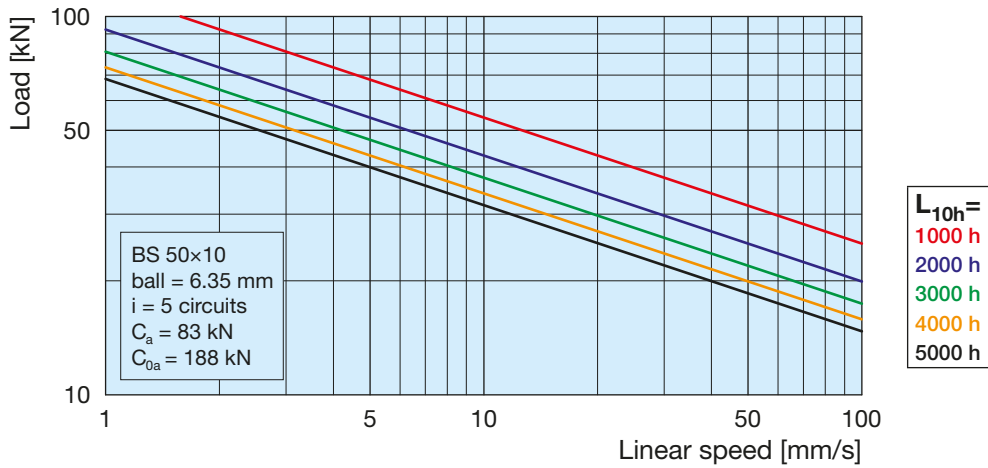
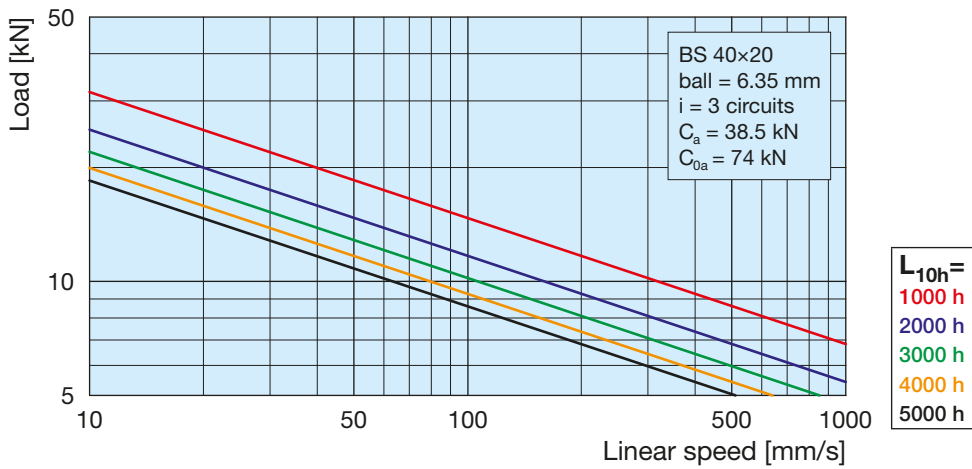
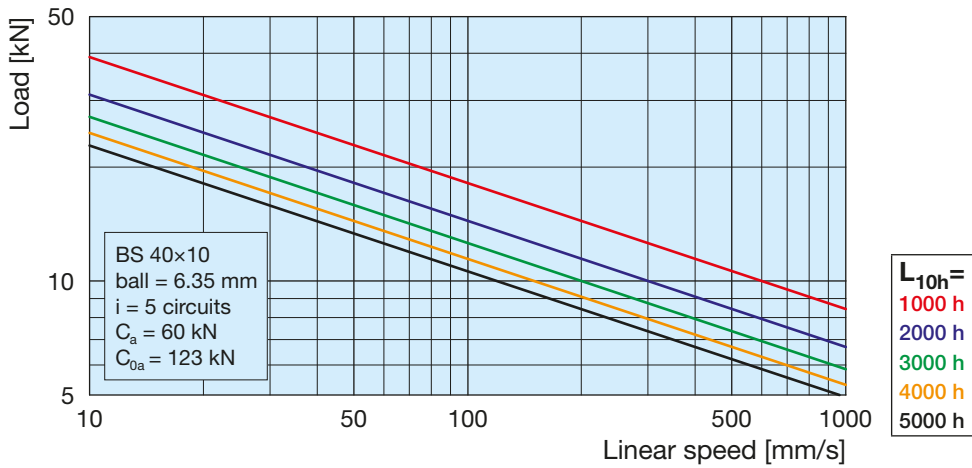

SERVOMECH Linear Actuators

1.7 Ball screw lifetime related to load and linear speed

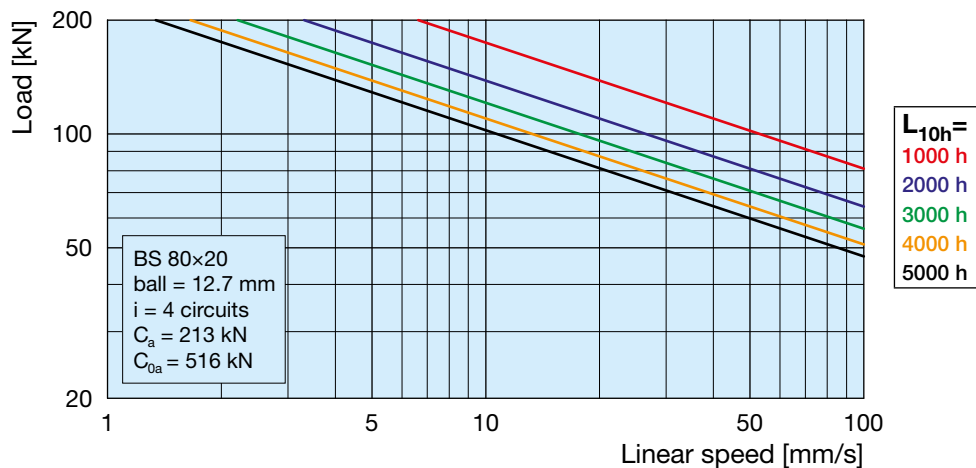
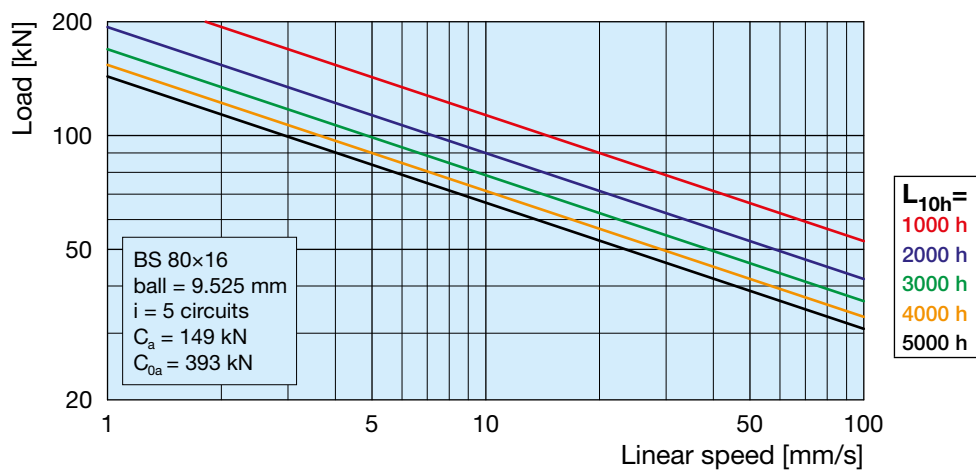
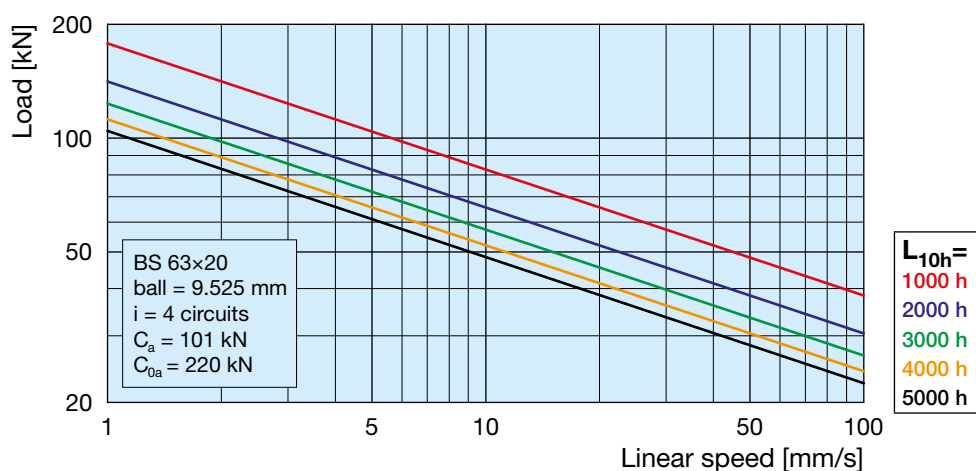
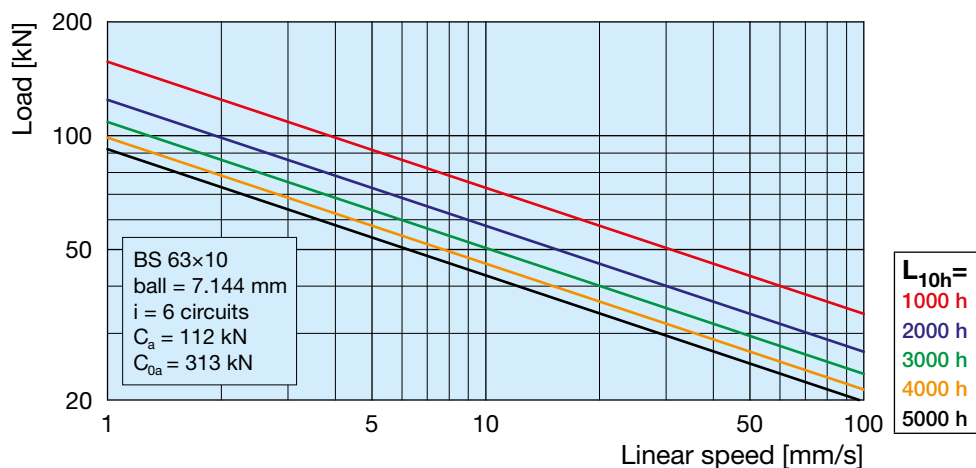

SERVOMECH Linear Actuators

1.7 Ball screw lifetime related to load and linear speed

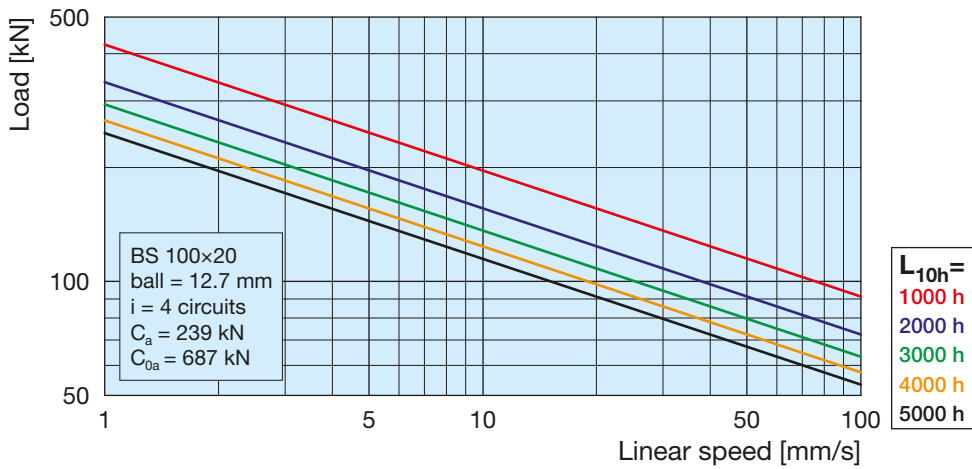
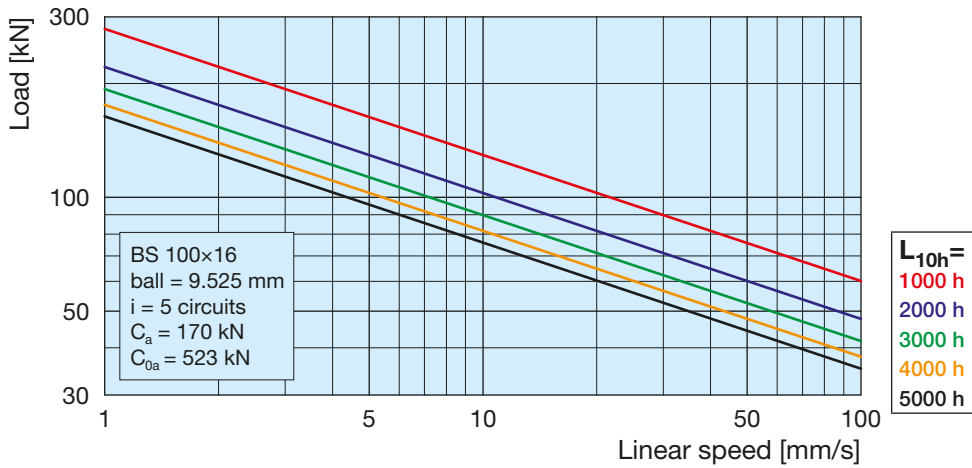

1.8 Actuator duty cycle permissible F_i related to dynamic load and speed

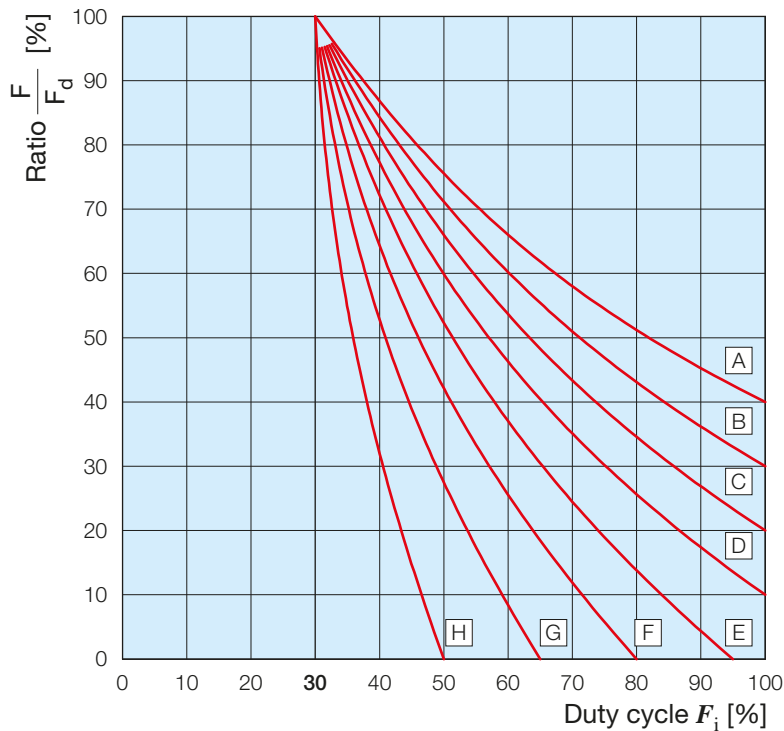

CURVE	Reference linear speed [mm/s]
A	5
B	10
C	25
D	50
E	75
F	100
G	200
H	400

F - dynamic load required by the application
 F_d - dynamic load stated in the actuator PERFORMANCE TABLE

SERVOMECH Linear Actuators

1.9 Self-locking conditions

A linear actuator is self-locking when:

- it is not running and, even when a push or pull load is applied on the push rod, it does not start running before the electric motor is switched on (statically self-locking);
- it is running and, after the electric motor is switched off it stops, even when a push or pull load is applied on the push rod (dynamically self-locking).

Self-locking or non self-locking conditions are defined for the following 4 different situations:

- 1) **Statically self-locking:** not running actuator, conditions without load vibrations; when applying a push or pull load (up to the maximum load permissible) the actuator does not start moving. This self-locking condition occurs whenever the self-locking coefficient¹⁾ is lower than 0.35.

- 2) **Dynamically self-locking:**
 - 2.1) Actuator in motion, the load direction is opposite to its running direction: by switching the motor off, the actuator stops (self-lock). This self-locking condition occurs whenever the self-locking coefficient¹⁾ is lower than 0.30.
 - 2.2) Actuator in motion, its running direction and the load applied has got the same direction: by switching the motor off, the actuator stop is not guaranteed. The actuator stops only if its self-locking coefficient¹⁾ is lower than 0.25 and in any case not always in the same position. In the above condition the use of a brake-motor is recommended to stop the actuator under load and to lock it on that position, avoiding an unexpected start in case of vibrations or load shocks.

- 3) **Uncertain locking:** with self-locking coefficient¹⁾ between 0.35 and 0.55, the actuators are in an uncertain locking condition. The self-locking condition depends on the load entity and on the system inertia. The use of a brake motor is recommended to ensure a self-locking condition. If necessary, contact SERVOMECH for a technical evaluation of the application.

- 4) **Non self-locking:** with self-locking coefficient¹⁾ higher than 0.55 the actuators are never self-locking. Note that even non self-locking actuators require a minimal push or pull force to start moving. The evaluation of this force value shall be done with SERVOMECH Engineering Dpt.

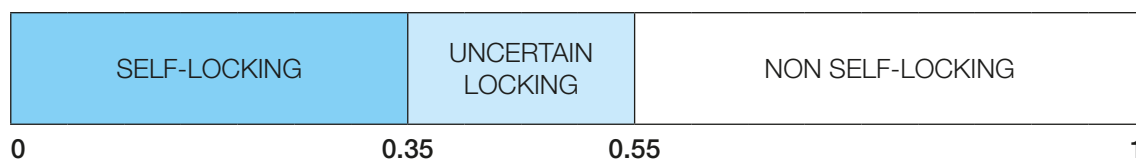

¹⁾ Values of the self-locking coefficient are stated in the relevant PERFORMANCES TABLES.

Linear actuators ATL Series and BSA Series

ATL - BSA Series, size 20 - 25 - 28 - 30 - 40

2

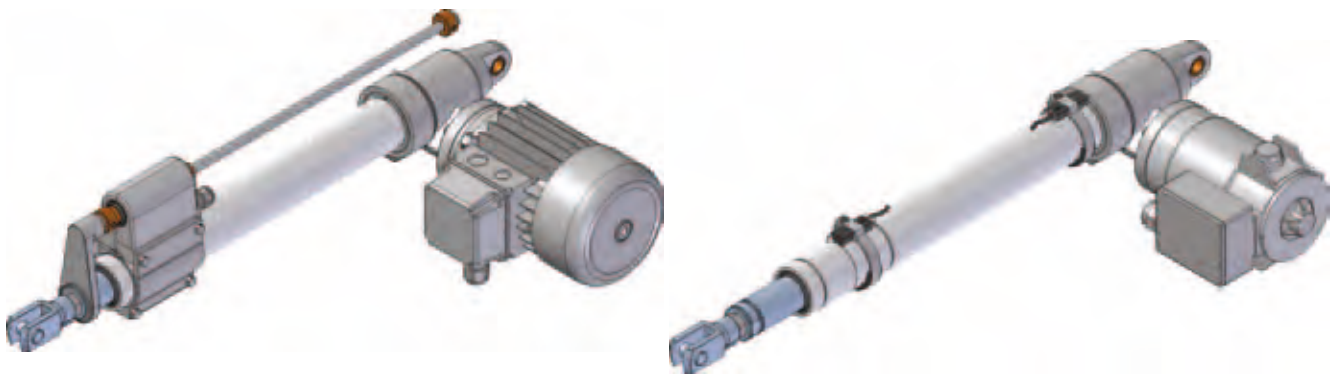

ATL - BSA Series, size 50 - 63 - 80

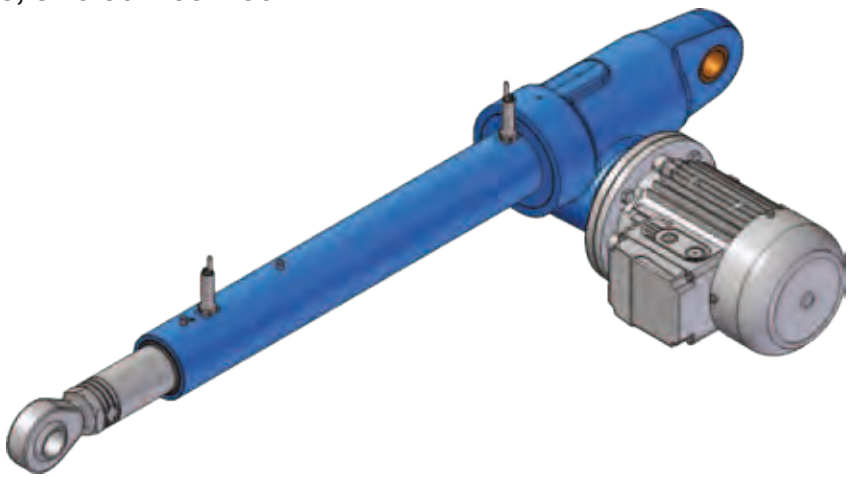

ATL - BSA Series, size 100 - 125

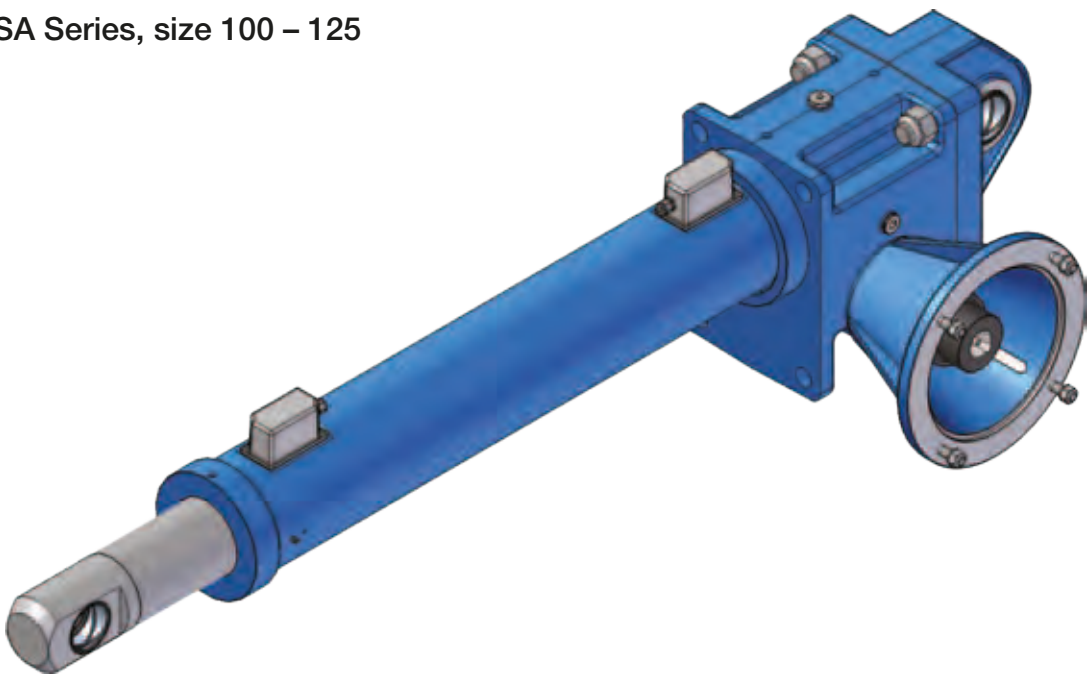

Linear actuators ATL Series and BSA Series

2.1 MANUFACTURING FEATURES

Input drive: worm gear - precision helical wheel, geometric design for high performance, involute profile ZI (UNI 4760 : Part 4), low angular backlash. Worm in case hardened steel 20 MnCr 5 (UNI EN 10084), with thread and input shafts ground. Helical wormwheel in bronze EN 1982 – CuSn12-C.

Housing: designed and manufactured in monobloc form to obtain a compact body able to sustain heavy axial loads and high machining accuracy. High quality materials are used:

- castings in hardened aluminium alloy EN 1706 AC-AISI10Mg T6
- castings in spheroidal graphite cast iron EN-GJS-500-7 (UNI EN 1563).

Acme screw:

- ISO trapezoidal thread ISO 2901 ... ISO 2904
- material: steel C 43 (UNI 7847)
- rolled or whirled
- subjected to straightening, to ensure accurate alignment in operation
- max. pitch error ± 0.05 mm over 300 mm length

Bronze nut:

- ISO trapezoidal thread ISO 2901 ... ISO 2904
- material: bronze EN 1982 – CuAl9-C (1-start thread)
- material: bronze EN 1982 – CuSn12-C (multiple start thread)
- max. axial backlash for new nut (0.10 ... 0.12) mm

Outer tube:

- material: aluminium alloy EN AW-6060 thick cold-drawn tube anodized ARC 20 (UNI 4522/66) inner diameter tolerance ISO H9
- steel St 52.2 (DIN 2391) cold-drawn tube inner diameter tolerance ISO H10 ... H11

Bearings:

- on motor axis: radial ball bearings or taper roller bearings
- on actuator axis: angular contact ball bearings or taper roller bearings, to avoid axial backlash and to assure high push-pull load capacity

Front attachment:

- standard – with threaded hollow bore, in stainless steel AISI 303 or steel C 43 (UNI 7847)

Rear bracket:

- in aluminium alloy for ATL-BSA 20, 25, 28, 30, 40
- in spheroidal graphite cast iron for ATL-BSA 50, 63, 80
- pin in stainless steel AISI 303

Electric stroke length limit device FCE:

- electric micro-switches activated by a shaped sleeve, for ATL-BSA 20, 25, 28, 30, 40, 50, 63, 80

Magnetic stroke end switches FCM:

- magnetic switches activated by a magnetic ring, for ATL-BSA 20, 25, 28, 30, 40

Proximity stroke end switches FCP:

- proximity switches activated by the nut, for ATL-BSA 50, 63, 80 and on request for ATL-BSA 100, 125

Electric stroke end switches FC:

- cam-operated electric switches for ATL-BSA 100, 125

Ball screw:

- designed and manufactured by SERVOMECH
- rolled and hardened material: steel 42 CrMo 4 (UNI EN 10083) accuracy grade: ISO IT 7
- hardened and machined material: steel 42 CrMo 4 (UNI EN 10083) accuracy grade: ISO IT 5

Ball nut:

- designed and manufactured by SERVOMECH
- material: steel 18 NiCrMo 5 (UNI EN 10084), case hardened
- max. axial backlash (0.07 ... 0.08) mm
- on request, ball nut with ZERO backlash or pre-loaded using selected diameter balls

Push rod:

- material: steel St 52 (DIN 2391) thick tube chrome-plated, min. chrome thickness 5/100 mm inner diameter tolerance ISO f7
- push rod in stainless steel INOX AISI 304 or special stainless steel on request

Linear actuators ATL Series

2.2 TECHNICAL DATA - acme screw linear actuators ATL Series

SIZE		ATL 20	ATL 25	ATL 28	ATL 30	ATL 40	
Push rod diameter	[mm]	25	30	30	35	40	
Outer tube diameter	[mm]	36	45	45	55	60	
Front attachment diameter	[mm]	10	12	12	14	20	
Rear attachment diameter	[mm]	12	12	12	14	20	
Input solid shaft diameter	[mm]	9	9	9	10	14	
Attachment for IEC standard motor (flange and hollow shaft)		56 B14	56 B14	63 B14	63 B14	71 B14	
Attachment for IEC standard motor (flange adapter + coupling)		—	—	—	—	—	
Max. dynamic load	[N]	4 000	6 000	8 000	10 000	12 000	
Max. static load	pull [N]	4 000	6 000	8 000	10 000	12 000	
	push [N]	6 000	8 000	10 000	12 000	15 000	
Ratio	RH	1 : 4 (5 : 20)	1 : 4 (5 : 20)	1 : 4 (5 : 20)	—	—	
	RV	1 : 6.25 (4 : 25)	1 : 6.25 (4 : 25)	1 : 6.25 (4 : 25)	1 : 4 (4 : 16)	1 : 5 (4 : 20)	
	RN	1 : 12.5 (2 : 25)	1 : 12.5 (2 : 25)	1 : 12.5 (2 : 25)	1 : 16 (2 : 32)	1 : 20	
	RL	1 : 25	1 : 25	1 : 25	1 : 24	1 : 25	
	RXL	1 : 50	1 : 50	1 : 50	1 : 34	1 : 55	
1-start acme screw		Tr 13.5×3	Tr 16×4	Tr 16×4	Tr 18×4	Tr 22×5	
Linear travel [mm] for 1 input shaft revolution	Ratio	RH1	0.75	1	1	—	—
		RV1	0.48	0.64	0.64	1	1
		RN1	0.24	0.32	0.32	0.25	0.25
		RL1	0.12	0.16	0.16	0.17	0.2
		RXL1	0.06	0.08	0.08	0.12	0.09
2-start acme screw		Tr 14×8 (P4)	Tr 16×8 (P4)	Tr 16×8 (P4)	Tr 18×8 (P4)	Tr 22×10 (P5)	
Linear travel [mm] for 1 input shaft revolution	Ratio	RH2	2	2	2	—	—
		RV2	1.28	1.28	1.28	2	2
		RN2	0.64	0.64	0.64	0.5	0.5
		RL2	0.32	0.32	0.32	0.33	0.4
		RXL2	0.16	0.16	0.16	0.24	0.18
Mass (actuator 100 mm stroke length, without motor, with lubricant)	[kg]	2.2	2.5	2.5	3.8	6.5	
Extra-mass for each additional 100 mm stroke length	[kg]	0.3	0.5	0.5	0.8	0.8	

Linear actuators ATL Series

2.2 TECHNICAL DATA - acme screw linear actuators ATL Series

2

ATL 50	ATL 63	ATL 80	ATL 100	ATL 125	SIZE	
50	60	90	100	150	Push rod diameter	[mm]
70	90	115	150	200	Outer tube diameter	[mm]
30	35	40	60	80	Front attachment diameter	[mm]
30	35	40	60	80	Rear attachment diameter	[mm]
19	24	28	32	38	Input solid shaft diameter	[mm]
63 B5 - 71 B5	80 B5	80 B5 - 90 B5	100 - 112 B5	—	Attachment for IEC standard motor (flange and hollow shaft)	
80 B5 - 90 B5 80 B14 - 90 B14	90 B5 - 100 B5 90 B14 - 100 B14	100 - 112 B5 100 - 112 B14	132 B5	132 B5 160 B5	Attachment for IEC standard motor (flange adapter + coupling)	
25 000	50 000	80 000	200 000	350 000	Max. dynamic load	[N]
25 000	50 000	80 000	200 000	350 000	pull	Max. static load [N]
25 000	50 000	100 000	200 000	350 000	push	
—	—	—	—	—	RH	Ratio
1 : 6 (4 : 24)	1 : 7 (4 : 28)	1 : 8 (4 : 32)	1 : 8 (4 : 32)	3 : 32	RV	
1 : 18 (2 : 36)	1 : 14 (2 : 28)	1 : 24	1 : 24	1 : 16 (2 : 32)	RN	
1 : 24	1 : 28	1 : 32	1 : 32	1 : 32	RL	
1 : 44	1 : 40	—	—	—	RXL	
Tr 30×6	Tr 40×7	Tr 60×12	Tr 70×12	Tr 100×12	1-start acme screw	
—	—	—	—	—	RH1	Linear travel [mm] for 1 input shaft revolution
1	1	1.5	1.5	1.12	RV1	
0.33	0.5	0.5	0.5	0.75	RN1	
0.25	0.25	0.38	0.38	0.38	RL1	
0.14	0.18	—	—	—	RXL1	
Tr 30×12 (P6)	Tr 40×14 (P7)	Tr 60×24 (P12)	Tr 70×24 (P12)	Tr 100×24 (P12)	2-start acme screw	
—	—	—	—	—	RH2	Linear travel [mm] for 1 input shaft revolution
2	2	3	3	2.25	RV2	
0.67	1	1	1	1.5	RN2	
0.5	0.5	0.75	0.75	0.75	RL2	
0.27	0.35	—	—	—	RXL2	
30	50	95	200	400	Mass (actuator 100 mm stroke length, without motor, with lubricant)	[kg]
2	3	5.5	10.5	18.5	Extra-mass for each additional 100 mm stroke length	[kg]

Linear actuators BSA Series

2.2 TECHNICAL DATA - ball screw linear actuators BSA Series

SIZE		BSA 20	BSA 25	BSA 28	BSA 30	BSA 40	
Push rod diameter	[mm]	25	30	30	35	40	
Outer tube diameter	[mm]	36	45	45	55	60	
Front attachment diameter	[mm]	10	12	12	14	20	
Rear attachment diameter	[mm]	12	12	12	14	20	
Input solid shaft diameter	[mm]	9	9	9	10	14	
Attachment for IEC standard motor (flange and hollow shaft)		56 B14	56 B14	63 B14	63 B14	71 B14	
Attachment for IEC standard motor (flange adapter + coupling)		—	—	—	—	—	
Max. dynamic load	[N]	4 000	6 000	7 500	9 000	12 000	
Max. static load	pull [N]	4 000	6 000	8 000	10 000	12 000	
	push [N]	6 000	8 000	10 000	12 000	15 000	
Ratio	RH	1 : 4 (5 : 20)	1 : 4 (5 : 20)	1 : 4 (5 : 20)	—	—	
	RV	1 : 6.25 (4 : 25)	1 : 6.25 (4 : 25)	1 : 6.25 (4 : 25)	1 : 4 (4 : 16)	1 : 5 (4 : 20)	
	RN	1 : 12.5 (2 : 25)	1 : 12.5 (2 : 25)	1 : 12.5 (2 : 25)	1 : 16 (2 : 32)	1 : 20	
	RL	1 : 25	1 : 25	1 : 25	1 : 24	1 : 25	
	RXL	1 : 50	1 : 50	1 : 50	1 : 34	1 : 55	
Ball screw (STANDARD)	Diameter × Lead	14×5	16×5	16×5	20×5	25×6	
	Ball [mm]	3.175 (1/8 ")	3.175 (1/8 ")	3.175 (1/8 ")	3.175 (1/8 ")	3.969 (5/32 ")	
	N° of circuits	2	3	4	3	3	
	Dynamic load C _a [N]	6 600	10 400	13 400	12 000	17 400	
	Static load C _{0a} [N]	8 600	15 600	20 900	21 200	30 500	
Linear travel [mm] for 1 input shaft revolution (STANDARD ball screw)	Ratio	RH1	1.25	1.25	1.25	—	—
		RV1	0.8	0.8	0.8	1.25	1.2
		RN1	0.4	0.4	0.4	0.31	0.3
		RL1	0.2	0.2	0.2	0.21	0.24
		RXL1	0.1	0.1	0.1	0.15	0.11
Mass (actuator 100 mm stroke length, without motor, with lubricant)	[kg]	2.2	2.5	2.5	3.8	6.5	
Extra-mass for each additional 100 mm stroke length	[kg]	0.3	0.5	0.5	0.8	0.9	

ON REQUEST

Ball screw (Diameter × Lead)		14×10	16×10	16×10	20×10	25×10
Ball [mm]		3.175 (1/8 ")	3.175 (1/8 ")	3.175 (1/8 ")	3.175 (1/8 ")	3.969 (5/32 ")
N° of circuits		2	3	3	3	3
Dynamic load C _a [N]		6 900	11 300	11 300	12 900	18 000
Static load C _{0a} [N]		9 300	18 000	18 000	23 500	33 000

NOTE: When these ball screws are used, the actuator length will be increased.
Please, contact SERVOMECH to get information about the exact length.

Linear actuators BSA Series

2.2 TECHNICAL DATA - ball screw linear actuators BSA Series

2

BSA 50	BSA 63	BSA 80	BSA 100	BSA 125	SIZE	
50	60	90	110	150	Push rod diameter	[mm]
70	90	115	160	200	Outer tube diameter	[mm]
30	35	40	60	80	Front attachment diameter	[mm]
30	35	40	60	80	Rear attachment diameter	[mm]
19	24	28	32	38	Input solid shaft diameter	[mm]
63 B5 - 71 B5	80 B5	80 B5 - 90 B5	100 - 112 B5	—	Attachment for IEC standard motor (flange and hollow shaft)	
80 B5 - 90 B5 80 B14 - 90 B14	90 B5 - 100 B5 90 B14 - 100 B14	100 - 112 B5 100 - 112 B14	132 B5	132 B5 160 B5	Attachment for IEC standard motor (flange adapter + coupling)	
25 000	50 000	80 000	108 000	123 000	Max. dynamic load	[N]
25 000	50 000	80 000	200 000	350 000	pull	Max. static load [N]
25 000	50 000	100 000	200 000	350 000	push	
—	—	—	—	—	RH	
1 : 6 (4 : 24)	1 : 7 (4 : 28)	1 : 8 (4 : 32)	1 : 8 (4 : 32)	3 : 32	RV	Ratio
1 : 18 (2 : 36)	1 : 14 (2 : 28)	1 : 24	1 : 24	1 : 16 (2 : 32)	RN	
1 : 24	1 : 28	1 : 32	1 : 32	1 : 32	RL	
1 : 44	1 : 40	—	—	—	RXL	
32×10	40×10	63×10	80×16	100×16	Diameter × Lead	
6.35 (1/4 ")	6.35 (1/4 ")	7.144 (9/32 ")	9.525 (3/8 ")	9.525 (3/8 ")	[mm] Ball	Ball screw (STANDARD)
4	5	6	5	5	N° of circuits	
41 800	60 000	112 000	149 000	170 000	[N] Dynamic load C _a	
73 000	123 000	313 000	393 000	523 000	[N] Static load C _{0a}	
—	—	—	—	—	RH1	Linear travel [mm] for 1 input shaft revolution (STANDARD ball screw)
1.67	1.43	1.25	2	1.5	RV1	
0.56	0.71	0.42	0.67	1	RN1	
0.42	0.36	0.31	0.5	0.5	RL1	
0.23	0.25	—	—	—	RXL1	
30	50	95	200	400	Mass (actuator 100 mm stroke length, without motor, with lubricant)	[kg]
2	3	5.5	12.5	19	Extra-mass for each additional 100 mm stroke length	[kg]

ON REQUEST

32×20	40×20	63×20	80×20	100×20	Ball screw (Diameter × Lead)
6.35 (1/4 ")	6.35 (1/4 ")	9.525 (3/8 ")	12.7 (1/2 ")	12.7 (1/2 ")	[mm] Ball
3	3	4	4	4	N° of circuits
32 200	38 500	101 000	213 000	239 000	[N] Dynamic load C _a
53 000	74 000	220 000	516 000	687 000	[N] Static load C _{0a}

NOTE: When these ball screws are used, the actuator length will be increased.
Please, contact SERVOMECH to get information about the exact length.

Linear actuators ATL Series

ACME SCREW LINEAR ACTUATORS ATL Series with AC 3-PHASE MOTOR
 PERFORMANCE with: Duty Cycle $F_d = 30\%$ over 10 min at ambient temperature 25 °C

LINEAR SPEED [mm/s]	DYNAMIC LOAD [N]	RATIO	MOTOR: POWER [kW] – N° of POLES SPEED [rpm]	SELF-LOCKING COEFFICIENT
ATL 20				
93	600 ¹⁾	RH2	0.12 kW 2-pole 2800	0.40
60	1000 ¹⁾	RV2	0.12 kW 2-pole 2800	0.41
46	850 ¹⁾	RH2	0.09 kW 4-pole 1400	0.40
35	1100 ¹⁾	RH1	0.12 kW 2-pole 2800	0.25
30	1750 ¹⁾	RN2	0.12 kW 2-pole 2800	0.35
22	1500 ¹⁾	RV1	0.12 kW 2-pole 2800	0.25
15	3000 ¹⁾	RL2	0.12 kW 2-pole 2800	0.27
11	4000 ¹⁾²⁾	RN1	0.12 kW 2-pole 2800	0.22
7.5	4000 ²⁾	RL2	0.09 kW 4-pole 1400	0.27
5.5	4000 ²⁾	RL1	0.12 kW 2-pole 2800	0.16
2.8	4000 ²⁾	RL1	0.09 kW 4-pole 1400	0.16
1.4	4000 ²⁾	RXL1	0.09 kW 4-pole 1400	0.11
ATL 25				
93	830 ¹⁾	RH2	0.12 kW 2-pole 2800	0.38
60	1250 ¹⁾	RV2	0.12 kW 2-pole 2800	0.38
46	1300 ¹⁾	RH1	0.12 kW 2-pole 2800	0.27
30	2200 ¹⁾	RN2	0.12 kW 2-pole 2800	0.33
23	1650 ¹⁾	RH1	0.09 kW 4-pole 1400	0.27
15	3750 ¹⁾	RL2	0.12 kW 2-pole 2800	0.25
7.5	5550 ¹⁾	RL1	0.12 kW 2-pole 2800	0.18
3.5	6000 ²⁾	RL1	0.09 kW 4-pole 1400	0.18
1.9	6000 ²⁾	RXL1	0.09 kW 4-pole 1400	0.12
ATL 28				
93	1250 ¹⁾	RH2	0.25 kW 2-pole 2800	0.38
60	1850 ¹⁾	RV2	0.25 kW 2-pole 2800	0.38
46	1950 ¹⁾	RH1	0.25 kW 2-pole 2800	0.27
30	3300 ¹⁾	RN2	0.25 kW 2-pole 2800	0.33
23	2500 ¹⁾	RH1	0.18 kW 4-pole 1400	0.27
15	5600 ¹⁾	RL2	0.25 kW 2-pole 2800	0.25
7.5	8000 ²⁾	RL1	0.25 kW 2-pole 2800	0.18
3.5	8000 ²⁾	RL1	0.18 kW 4-pole 1400	0.18
1.9	8000 ²⁾	RXL1	0.18 kW 4-pole 1400	0.12
ATL 30				
93	1650 ¹⁾	RV2	0.25 kW 2-pole 2800	0.37
46	2550 ¹⁾	RV1	0.25 kW 2-pole 2800	0.25
23	5200 ¹⁾	RN2	0.25 kW 2-pole 2800	0.28
15	6850 ¹⁾	RL2	0.25 kW 2-pole 2800	0.22
11	8500 ¹⁾	RXL2	0.25 kW 2-pole 2800	0.18
7.5	10000 ¹⁾²⁾	RL1	0.25 kW 2-pole 2800	0.16
5.5	10000 ²⁾	RXL1	0.25 kW 2-pole 2800	0.13
4	10000 ²⁾	RL1	0.18 kW 4-pole 1400	0.16
2.7	10000 ²⁾	RXL1	0.18 kW 4-pole 1400	0.13
ATL 40				
93	3500 ¹⁾	RV2	0.55 kW 2-pole 2800	0.37
46	5400 ¹⁾	RV1	0.55 kW 2-pole 2800	0.26
23	10500 ¹⁾	RN2	0.55 kW 2-pole 2800	0.25
18	12000 ²⁾	RL2	0.55 kW 2-pole 2800	0.24
11	12000 ²⁾	RN1	0.55 kW 2-pole 2800	0.18
8.5	12000 ²⁾	RXL2	0.55 kW 2-pole 2800	0.12
5.5	12000 ²⁾	RN1	0.37 kW 4-pole 1400	0.18
4.5	12000 ²⁾	RL1	0.37 kW 4-pole 1400	0.17
2.1	12000 ²⁾	RXL1	0.37 kW 4-pole 1400	0.08

Linear actuators ATL Series

ACME SCREW LINEAR ACTUATORS ATL Series with AC 3-PHASE MOTOR
PERFORMANCE with: Duty Cycle $F_i = 30\%$ over 10 min at ambient temperature 25 °C

LINEAR SPEED [mm/s]	DYNAMIC LOAD [kN]	RATIO	MOTOR: POWER [kW] – N° of POLES SPEED [rpm]	SELF-LOCKING COEFFICIENT
ATL 50				
93	13.7 ¹⁾	RV2	2.2 kW 2-pole 2800	0.34
46	17 ¹⁾	RV2	1.5 kW 4-pole 1400	0.34
30	25 ²⁾	RN2	2.2 kW 2-pole 2800	0.26
23	25 ²⁾	RV1	1.5 kW 4-pole 1400	0.24
15	25 ²⁾	RN2	1.5 kW 4-pole 1400	0.26
11	25 ²⁾	RL2	0.75 kW 4-pole 1400	0.23
7.5	25 ²⁾	RN1	0.75 kW 4-pole 1400	0.18
5.5	25 ²⁾	RL1	0.75 kW 4-pole 1400	0.15
3.2	25 ²⁾	RXL1	0.37 kW 4-pole 1400	0.12
ATL 63				
93	18 ¹⁾	RV2	3 kW 2-pole 2800	0.32
46	33 ¹⁾	RV2	3 kW 4-pole 1400	0.32
23	45 ¹⁾	RV1	3 kW 4-pole 1400	0.21
11	40 ¹⁾	RN1	1.5 kW 4-pole 1400	0.18
5.5	50 ²⁾	RL1	1.5 kW 4-pole 1400	0.13
4.1	50 ²⁾	RXL1	1.1 kW 4-pole 1400	0.12
ATL 80				
140	17 ¹⁾	RV2	4 kW 2-pole 2800	0.34
70	31 ¹⁾	RV2	4 kW 4-pole 1400	0.34
46	41 ¹⁾	RN2	4 kW 2-pole 2800	0.24
35	48 ¹⁾	RV1	4 kW 4-pole 1400	0.23
23	73 ¹⁾	RN2	4 kW 4-pole 1400	0.24
17	80 ²⁾	RL2	4 kW 4-pole 1400	0.22
11	80 ²⁾	RN1	4 kW 4-pole 1400	0.16
8.5	80 ²⁾	RL1	3 kW 4-pole 1400	0.15
ATL 100				
140	31 ¹⁾	RV2	7.5 kW 2-pole 2800	0.31
70	57 ¹⁾	RV2	7.5 kW 4-pole 1400	0.31
47	75 ¹⁾	RN2	7.5 kW 2-pole 2800	0.22
35	95 ¹⁾	RL2	7.5 kW 2-pole 2800	0.20
23	137 ¹⁾	RN2	7.5 kW 4-pole 1400	0.22
18	167 ¹⁾	RL2	7.5 kW 4-pole 1400	0.20
12	194 ¹⁾	RN1	7.5 kW 4-pole 1400	0.15
9	200 ²⁾	RL1	7.5 kW 4-pole 1400	0.13
ATL 125				
105	74 ¹⁾	RV2	15 kW 2-pole 2800	0.24
70	102 ¹⁾	RN2	15 kW 2-pole 2800	0.22
53	131 ¹⁾	RV2	15 kW 4-pole 1400	0.24
35	180 ¹⁾	RN2	15 kW 4-pole 1400	0.22
26	183 ¹⁾	RV1	15 kW 4-pole 1400	0.15
18	302 ¹⁾	RL2	15 kW 4-pole 1400	0.17
9	350 ²⁾	RL1	15 kW 4-pole 1400	0.10

1) value limited by electric motor power

The total dynamic efficiency (η) of ATL Series actuators, used to determine the DYNAMIC LOAD is calculated as follows:

$$\eta = \eta_1 \times \eta_2 \times \eta_3$$

where:

η_1 – wormgear dynamic efficiency, calculated according to BS 721 : Part 2 : 1983

η_2 – acme screw-bronze nut dynamic efficiency, calculated with reference to the speed

$\eta_3 = 0.9$ – bearings and sealing elements “efficiency”

2) limit value of linear actuator dynamic load capacity (see pages 42 ... 43)

Linear actuators ATL Series

ACME SCREW LINEAR ACTUATORS ATL Series with AC 1-PHASE MOTOR
 PERFORMANCE with: Duty Cycle $F_d = 30\%$ over 10 min at ambient temperature 25 °C

LINEAR SPEED [mm/s]	DYNAMIC LOAD [N]	RATIO	MOTOR: POWER [kW] – N° of POLES SPEED [rpm]	SELF-LOCKING COEFFICIENT
ATL 20				
93	600 ¹⁾	RH2	0.12 kW 2-pole 2800	0.40
60	1000 ¹⁾	RV2	0.12 kW 2-pole 2800	0.41
46	850 ¹⁾	RH2	0.09 kW 4-pole 1400	0.40
35	1100 ¹⁾	RH1	0.12 kW 2-pole 2800	0.25
30	1750 ¹⁾	RN2	0.12 kW 2-pole 2800	0.35
22	1500 ¹⁾	RV1	0.12 kW 2-pole 2800	0.25
15	3000 ¹⁾	RL2	0.12 kW 2-pole 2800	0.27
11	3750 ¹⁾	RN1	0.12 kW 2-pole 2800	0.22
7.5	4000 ¹⁾²⁾	RL2	0.09 kW 4-pole 1400	0.27
5.5	4000 ²⁾	RL1	0.12 kW 2-pole 2800	0.16
2.8	4000 ²⁾	RL1	0.09 kW 4-pole 1400	0.16
1.4	4000 ²⁾	RXL1	0.09 kW 4-pole 1400	0.11
ATL 25				
93	770 ¹⁾	RH2	0.12 kW 2-pole 2800	0.38
60	1100 ¹⁾	RV2	0.12 kW 2-pole 2800	0.38
46	1200 ¹⁾	RH1	0.12 kW 2-pole 2800	0.27
28	2050 ¹⁾	RN2	0.12 kW 2-pole 2800	0.33
23	1600 ¹⁾	RH1	0.09 kW 4-pole 1400	0.27
14	3450 ¹⁾	RL2	0.12 kW 2-pole 2800	0.25
7	5100 ¹⁾	RL1	0.12 kW 2-pole 2800	0.18
3.5	6000 ²⁾	RL1	0.09 kW 4-pole 1400	0.18
1.9	6000 ²⁾	RXL1	0.09 kW 4-pole 1400	0.12
ATL 28				
93	1250 ¹⁾	RH2	0.25 kW 2-pole 2800	0.38
60	1850 ¹⁾	RV2	0.25 kW 2-pole 2800	0.38
46	1950 ¹⁾	RH1	0.25 kW 2-pole 2800	0.27
30	3300 ¹⁾	RN2	0.25 kW 2-pole 2800	0.33
23	2500 ¹⁾	RH1	0.18 kW 4-pole 1400	0.27
15	5600 ¹⁾	RL2	0.25 kW 2-pole 2800	0.25
7.5	8000 ²⁾	RL1	0.25 kW 2-pole 2800	0.18
3.5	8000 ²⁾	RL1	0.18 kW 4-pole 1400	0.18
1.9	8000 ²⁾	RXL1	0.18 kW 4-pole 1400	0.12
ATL 30				
93	1500 ¹⁾	RV2	0.25 kW 2-pole 2800	0.37
46	2350 ¹⁾	RV1	0.25 kW 2-pole 2800	0.25
23	4800 ¹⁾	RN2	0.25 kW 2-pole 2800	0.28
15	6300 ¹⁾	RL2	0.25 kW 2-pole 2800	0.22
11	8000 ¹⁾	RXL2	0.25 kW 2-pole 2800	0.18
7.5	9200 ¹⁾	RL1	0.25 kW 2-pole 2800	0.16
5.5	10000 ²⁾	RXL1	0.25 kW 2-pole 2800	0.13
4	10000 ²⁾	RL1	0.18 kW 4-pole 1400	0.16
2.7	10000 ²⁾	RXL1	0.18 kW 4-pole 1400	0.13
ATL 40				
93	3400 ¹⁾	RV2	0.55 kW 2-pole 2800	0.37
46	5400 ¹⁾	RV1	0.55 kW 2-pole 2800	0.26
23	10000 ¹⁾	RN2	0.55 kW 2-pole 2800	0.25
18	12000 ²⁾	RL2	0.55 kW 2-pole 2800	0.24
11	12000 ²⁾	RN1	0.55 kW 2-pole 2800	0.18
8.5	12000 ²⁾	RXL2	0.55 kW 2-pole 2800	0.12
5.5	12000 ²⁾	RN1	0.37 kW 4-pole 1400	0.18
4.5	12000 ²⁾	RL1	0.37 kW 4-pole 1400	0.17
2.1	12000 ²⁾	RXL1	0.37 kW 4-pole 1400	0.08

Linear actuators ATL Series

ACME SCREW LINEAR ACTUATORS ATL Series with DC MOTOR

PERFORMANCE with: Duty Cycle $F_i = 30\%$ over 10 min at ambient temperature 25 °C

LINEAR SPEED [mm/s]	DYNAMIC LOAD [N]	RATIO	CURRENT [A]	SELF-LOCKING COEFFICIENT
ATL 20 with DC motor 24 V 3000 rpm 100 W 5.5 A				
100	600 ¹⁾	RH2	10	0.40
64	920 ¹⁾	RV2	9.5	0.41
37	1150 ¹⁾	RH1	9	0.25
32	1650 ¹⁾	RN2	9	0.35
24	1700 ¹⁾	RV1	8.5	0.25
16	2800 ¹⁾	RL2	8.5	0.27
12	2900 ¹⁾	RN1	8	0.22
8	4000 ²⁾	RXL2	6.5	0.18
6	4000 ²⁾	RL1	6	0.16
3	4000 ²⁾	RXL1	3	0.11
ATL 25 with DC motor 24 V 3000 rpm 150 W 8.4 A				
100	900 ¹⁾	RH2	14.5	0.38
64	1330 ¹⁾	RV2	13.5	0.38
50	1450 ¹⁾	RH1	15	0.27
32	2100 ¹⁾	RV1	14	0.27
16	4000 ¹⁾	RL2	12	0.25
8	6000 ²⁾	RL1	11.5	0.18
4	6000 ²⁾	RXL1	5.5	0.12
ATL 30 with DC motor 24 V 3000 rpm 300 W 15.6 A				
100	1750 ¹⁾	RV2	26	0.37
50	2750 ¹⁾	RV1	27	0.25
25	5600 ¹⁾	RN2	23	0.28
16	7500 ¹⁾	RL2	21	0.22
12	8400 ¹⁾	RN1	22	0.20
8	10000 ²⁾	RL1	18	0.16
6	10000 ²⁾	RXL1	15	0.13
ATL 40 with DC motor 24 V 3000 rpm 500 W 25 A				
100	3000 ¹⁾	RV2	43	0.37
50	4700 ¹⁾	RV1	44	0.26
25	9200 ¹⁾	RN2	38	0.25
20	11000 ¹⁾	RL2	36	0.24
12	12000 ²⁾	RN1	31	0.18
10	12000 ²⁾	RL1	26	0.17
4.5	12000 ²⁾	RXL1	17	0.08

1) value limited by electric motor power

The total dynamic efficiency (η) of ATL Series actuators, used to determine the DYNAMIC LOAD is calculated as follows:

$$\eta = \eta_1 \times \eta_2 \times \eta_3$$

where:

η_1 – wormgear dynamic efficiency, calculated according to BS 721 : Part 2 : 1983

η_2 – acme screw-bronze nut dynamic efficiency, calculated with reference to the speed

$\eta_3 = 0.9$ – bearings and sealing elements "efficiency"

2) limit value of linear actuator dynamic load capacity (see page 42)

Linear actuators BSA Series

BALL SCREW LINEAR ACTUATORS BSA Series with AC 3-PHASE MOTOR
PERFORMANCE with: Duty Cycle $F_i = 100\%$ at ambient temperature $25\text{ }^\circ\text{C}$

LINEAR SPEED [mm/s]	DYNAMIC LOAD [N]	RATIO	MOTOR: POWER [kW] — N° of POLES SPEED [rpm]	SELF-LOCKING COEFFICIENT
BSA 20				
60	1650 ¹⁾	RH1	0.12 kW 2-pole 2800	0.56
37	2200 ²⁾	RV1	0.12 kW 2-pole 2800	0.57
30	2250 ¹⁾	RH1	0.09 kW 4-pole 1400	0.56
20	2800 ²⁾	RN1	0.12 kW 2-pole 2800	0.49
9	3500 ²⁾	RN1	0.09 kW 4-pole 1400	0.49
4.5	4000 ³⁾	RL1	0.09 kW 4-pole 1400	0.37
2.3	4000 ³⁾	RXL1	0.09 kW 4-pole 1400	0.25
BSA 25				
60	1650 ¹⁾	RH1	0.12 kW 2-pole 2800	0.56
37	2550 ¹⁾	RV1	0.12 kW 2-pole 2800	0.56
30	2250 ¹⁾	RH1	0.09 kW 4-pole 1400	0.56
20	4400 ²⁾	RN1	0.12 kW 2-pole 2800	0.48
9	5500 ²⁾	RN1	0.09 kW 4-pole 1400	0.48
4.5	6000 ³⁾	RL1	0.09 kW 4-pole 1400	0.37
2.3	6000 ³⁾	RXL1	0.09 kW 4-pole 1400	0.25
BSA 28				
60	3300 ¹⁾	RH1	0.25 kW 2-pole 2800	0.56
37	4500 ²⁾	RV1	0.25 kW 2-pole 2800	0.56
30	4500 ¹⁾	RH1	0.18 kW 4-pole 1400	0.56
20	5650 ²⁾	RN1	0.25 kW 2-pole 2800	0.48
9	7100 ²⁾	RN1	0.18 kW 4-pole 1400	0.48
4.5	7500 ³⁾	RL1	0.18 kW 4-pole 1400	0.37
2.3	7500 ³⁾	RXL1	0.18 kW 4-pole 1400	0.25
BSA 30				
60	3350 ¹⁾	RV1	0.25 kW 2-pole 2800	0.56
30	4350 ²⁾	RV1	0.18 kW 4-pole 1400	0.56
15	5500 ²⁾	RN1	0.25 kW 2-pole 2800	0.43
10	6300 ²⁾	RL1	0.25 kW 2-pole 2800	0.34
7	7000 ²⁾	RN1	0.18 kW 4-pole 1400	0.43
5	7900 ²⁾	RL1	0.18 kW 4-pole 1400	0.34
3.5	9000 ²⁾	RXL1	0.18 kW 4-pole 1400	0.30
BSA 40				
56	5400 ²⁾	RV1	0.55 kW 2-pole 2800	0.56
28	6800 ²⁾	RV1	0.37 kW 4-pole 1400	0.56
14	8600 ²⁾	RN1	0.55 kW 2-pole 2800	0.38
11	9250 ²⁾	RL1	0.55 kW 2-pole 2800	0.36
7	10800 ²⁾	RN1	0.37 kW 4-pole 1400	0.38
5.5	11600 ²⁾	RL1	0.37 kW 4-pole 1400	0.36
2.5	12000 ³⁾	RXL1	0.37 kW 4-pole 1400	0.20

¹⁾ value limited by electric motor power; ball screw lifetime $L_{10h} > 1000$ hours (see diagrams on pages 33 ... 35)

The total dynamic efficiency (η) of BSA Series actuators, used to determine the DYNAMIC LOAD is calculated as follows:

$$\eta = \eta_1 \times \eta_2 \times \eta_3$$

where:

η_1 – wormgear dynamic efficiency, calculated according to BS 721 : Part 2 : 1983

$\eta_2 = 0.9$ – ball screw - nut efficiency

$\eta_3 = 0.9$ – bearings and sealing elements "efficiency"

²⁾ value related to the ball screw lifetime $L_{10h} = 1000$ h, with constant load, without load vibrations nor shocks; for different lifetime refer to diagrams on pages 33 ... 35

³⁾ limit value of linear actuator dynamic load capacity (see page 44)

Linear actuators BSA Series

BALL SCREW LINEAR ACTUATORS BSA Series with AC 3-PHASE MOTOR
PERFORMANCE with: Duty Cycle $F_i = 100\%$ at ambient temperature $25\text{ }^\circ\text{C}$

LINEAR SPEED [mm/s]	DYNAMIC LOAD [kN]	RATIO	MOTOR: POWER [kW] – N° of POLES SPEED [rpm]	SELF-LOCKING COEFFICIENT
BSA 50				
78	14 ²⁾	RV1	1.5 kW 2-pole 2800	0.56
40	17 ²⁾	RV1	1.1 kW 4-pole 1400	0.56
25	20 ²⁾	RN1	1.1 kW 2-pole 2800	0.43
20	22 ²⁾	RL1	1.1 kW 2-pole 2800	0.37
13	25 ^{2) 3)}	RN1	0.75 kW 4-pole 1400	0.43
10	25 ³⁾	RL1	0.75 kW 4-pole 1400	0.37
5.3	25 ³⁾	RXL1	0.37 kW 4-pole 1400	0.31
BSA 63				
66	21 ²⁾	RV1	2.2 kW 2-pole 2800	0.56
33	25 ¹⁾	RV1	1.5 kW 4-pole 1400	0.56
17	31 ¹⁾	RN1	0.75 kW 4-pole 1400	0.46
8	41 ²⁾	RL1	0.75 kW 4-pole 1400	0.35
5.8	47 ²⁾	RXL1	0.75 kW 4-pole 1400	0.34
BSA 80				
58	39 ¹⁾	RV1	3 kW 2-pole 2800	0.56
29	51 ²⁾	RV1	2.2 kW 4-pole 1400	0.56
19	59 ²⁾	RN1	2.2 kW 2-pole 2800	0.38
15	65 ²⁾	RL1	1.5 kW 2-pole 2800	0.35
10	73 ¹⁾	RN1	1.1 kW 4-pole 1400	0.38
7	81 ²⁾	RL1	1.1 kW 4-pole 1400	0.35
BSA 100				
93	54 ²⁾	RV1	7.5 kW 2-pole 2800	0.60
47	68 ²⁾	RV1	5.2 kW 4-pole 1400	0.60
31	78 ²⁾	RN1	4 kW 2-pole 2800	0.42
23	86 ^{2) 3)}	RL1	3 kW 2-pole 2800	0.39
16	98 ²⁾	RN1	3 kW 4-pole 1400	0.42
12	108 ²⁾	RL1	2.2 kW 4-pole 1400	0.39
BSA 125				
70	68 ²⁾	RV1	7.5 kW 2-pole 2800	0.58
47	78 ²⁾	RN1	5.5 kW 2-pole 2800	0.52
35	85 ²⁾	RV1	4 kW 4-pole 1400	0.58
23	98 ²⁾	RN1	5.5 kW 4-pole 1400	0.52
12	123 ²⁾	RL1	5.5 kW 4-pole 1400	0.40

1) value limited by electric motor power; ball screw lifetime $L_{10h} > 1000$ hours (see diagrams on pages 35 ... 38)

The total dynamic efficiency (η) of BSA Series actuators, used to determine the DYNAMIC LOAD is calculated as follows:

$$\eta = \eta_1 \times \eta_2 \times \eta_3$$

where:

η_1 – wormgear dynamic efficiency, calculated according to BS 721 : Part 2 : 1983

$\eta_2 = 0.9$ – ball screw - nut efficiency

$\eta_3 = 0.9$ – bearings and sealing elements "efficiency"

2) value related to the ball screw lifetime $L_{10h} = 1000$ h, with constant load, without load vibrations nor shocks; for different lifetime refer to diagrams on pages 35 ... 38

3) limit value of linear actuator dynamic load capacity (see page 45)

Linear actuators BSA Series

BALL SCREW LINEAR ACTUATORS BSA Series with AC 1-PHASE MOTOR
PERFORMANCE with: Duty Cycle $F_i = 100\%$ at ambient temperature $25\text{ }^\circ\text{C}$

LINEAR SPEED [mm/s]	DYNAMIC LOAD [N]	RATIO	MOTOR: POWER [kW] – N° of POLES SPEED [rpm]	SELF-LOCKING COEFFICIENT
BSA 20				
60	1550 ¹⁾	RH1	0.12 kW 2-pole 2800	0.56
37	2200 ²⁾	RV1	0.12 kW 2-pole 2800	0.57
30	2250 ¹⁾	RH1	0.09 kW 4-pole 1400	0.56
20	2800 ²⁾	RN1	0.12 kW 2-pole 2800	0.49
9	3500 ²⁾	RN1	0.09 kW 4-pole 1400	0.49
4.5	4000 ³⁾	RL1	0.09 kW 4-pole 1400	0.37
2.3	4000 ³⁾	RXL1	0.09 kW 4-pole 1400	0.25
BSA 25				
60	1550 ¹⁾	RH1	0.12 kW 2-pole 2800	0.56
37	2450 ¹⁾	RV1	0.12 kW 2-pole 2800	0.56
30	2200 ¹⁾	RH1	0.09 kW 4-pole 1400	0.56
20	4400 ²⁾	RN1	0.12 kW 2-pole 2800	0.48
9	5500 ²⁾	RN1	0.09 kW 4-pole 1400	0.48
4.5	6000 ³⁾	RL1	0.09 kW 4-pole 1400	0.37
2.3	6000 ³⁾	RXL1	0.09 kW 4-pole 1400	0.25
BSA 28				
60	3200 ¹⁾	RH1	0.25 kW 2-pole 2800	0.56
37	4500 ²⁾	RV1	0.25 kW 2-pole 2800	0.56
30	4450 ¹⁾	RH1	0.18 kW 4-pole 1400	0.56
20	5650 ²⁾	RN1	0.25 kW 2-pole 2800	0.48
9	7100 ²⁾	RN1	0.18 kW 4-pole 1400	0.48
4.5	7500 ³⁾	RL1	0.18 kW 4-pole 1400	0.37
2.3	7500 ³⁾	RXL1	0.18 kW 4-pole 1400	0.25
BSA 30				
60	3300 ¹⁾	RV1	0.25 kW 2-pole 2800	0.56
30	4350 ²⁾	RV1	0.18 kW 4-pole 1400	0.56
15	5500 ²⁾	RN1	0.25 kW 2-pole 2800	0.43
10	6300 ²⁾	RL1	0.25 kW 2-pole 2800	0.34
7	7000 ²⁾	RN1	0.18 kW 4-pole 1400	0.43
5	7900 ²⁾	RL1	0.18 kW 4-pole 1400	0.34
3.5	9000 ²⁾	RXL1	0.18 kW 4-pole 1400	0.30
BSA 40				
56	5400 ²⁾	RV1	0.55 kW 2-pole 2800	0.56
28	6800 ²⁾	RV1	0.37 kW 4-pole 1400	0.56
14	8600 ²⁾	RN1	0.55 kW 2-pole 2800	0.38
11	9250 ²⁾	RL1	0.55 kW 2-pole 2800	0.36
7	10800 ²⁾	RN1	0.37 kW 4-pole 1400	0.38
5.5	11600 ²⁾	RL1	0.37 kW 4-pole 1400	0.36
2.5	12000 ³⁾	RXL1	0.37 kW 4-pole 1400	0.20

1) value limited by electric motor power; ball screw lifetime $L_{10h} > 1000$ hours (see diagrams on pages 33 ... 35)

The total dynamic efficiency (η) of BSA Series actuators, used to determine the DYNAMIC LOAD is calculated as follows:

$$\eta = \eta_1 \times \eta_2 \times \eta_3$$

where:

η_1 – wormgear dynamic efficiency, calculated according to BS 721 : Part 2 : 1983

$\eta_2 = 0.9$ – ball screw - nut efficiency

$\eta_3 = 0.9$ – bearings and sealing elements "efficiency"

- 2) value related to the ball screw lifetime $L_{10h} = 1000$ h, with constant load, without load vibrations nor shocks; for different lifetime refer to diagrams on pages 33 ... 35
- 3) limit value of linear actuator dynamic load capacity (see page 44)

Linear actuators BSA Series

BALL SCREW LINEAR ACTUATORS BSA Series with DC MOTOR
PERFORMANCE with: Duty Cycle $F_i = 100\%$ at ambient temperature $25\text{ }^\circ\text{C}$

LINEAR SPEED [mm/s]	DYNAMIC LOAD [N]	RATIO	CURRENT [A]	SELF-LOCKING COEFFICIENT
BSA 20 with DC motor 24 V 3000 g/min 100 W 5.5 A				
62	1200 ¹⁾	RH1	6.5	0.56
40	1850 ¹⁾	RV1	6.5	0.57
20	2750 ²⁾	RN1	5.5	0.49
10	3500 ²⁾	RL1	3.5	0.37
5	4000 ³⁾	RXL1	2.5	0.25
BSA 25 with DC motor 24 V 3000 g/min 150 W 8.4 A				
62	1800 ¹⁾	RH1	9.5	0.56
40	2800 ¹⁾	RV1	9.5	0.57
20	4300 ²⁾	RN1	7	0.48
10	5400 ²⁾	RL1	5	0.37
5	6000 ³⁾	RXL1	3	0.25
BSA 30 with DC motor 24 V 3000 g/min 300 W 15.6 A				
62	3400 ²⁾	RV1	16	0.56
15	5350 ²⁾	RN1	7	0.43
10	6150 ²⁾	RL1	6	0.34
7.5	7000 ²⁾	RXL1	5	0.30
BSA 40 with DC motor 24 V 3000 g/min 500 W 25 A				
60	5300 ²⁾	RV1	25	0.56
15	8400 ²⁾	RN1	12	0.38
12	9000 ²⁾	RL1	10	0.36
5.5	12000 ^{2) 3)}	RXL1	8	0.20

1) value limited by electric motor power; ball screw lifetime $L_{10h} > 1000$ hours (see diagrams on pages 33 ... 35)

The total dynamic efficiency (η) of BSA Series actuators, used to determine the DYNAMIC LOAD is calculated as follows:

$$\eta = \eta_1 \times \eta_2 \times \eta_3$$

where:

η_1 – wormgear dynamic efficiency, calculated according to BS 721 : Part 2 : 1983

$\eta_2 = 0.9$ – ball screw - nut efficiency

$\eta_3 = 0.9$ – bearings and sealing elements "efficiency"

- 2) value related to the ball screw lifetime $L_{10h} = 1000$ h, with constant load, without load vibrations nor shocks; for different lifetime refer to diagrams on pages 33 ... 35
- 3) limit value of linear actuator dynamic load capacity (see page 44)

Linear actuators ATL Series

ACME SCREW LINEAR ACTUATORS ATL Series, size 20 – 25 – 28 – 30 – 40
AC 3-phase or 1-phase MOTOR – with Electric Stroke Limit Device FCE

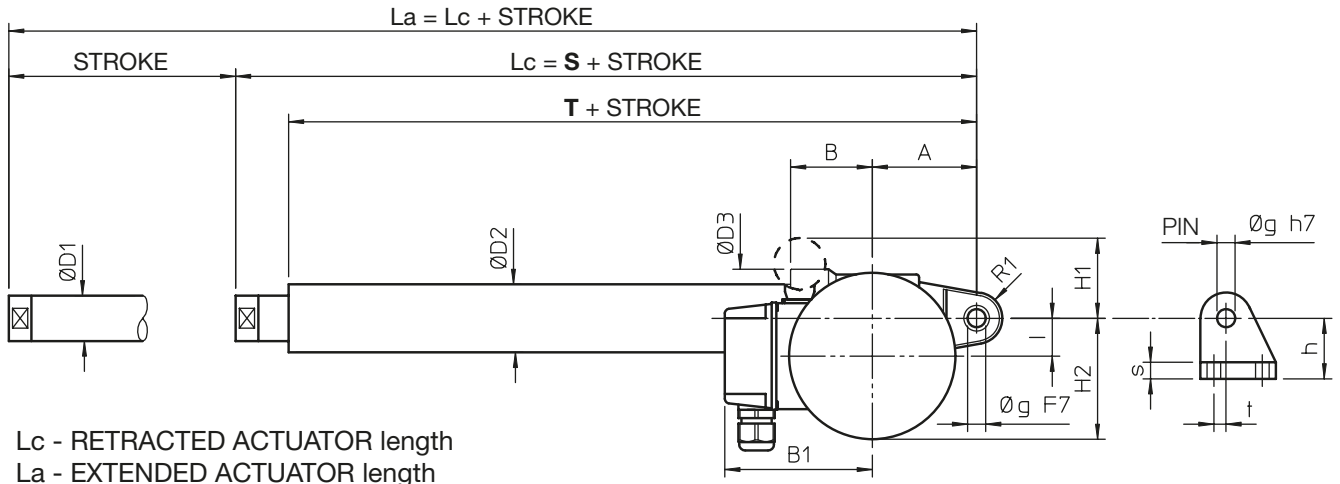

Lc - RETRACTED ACTUATOR length
 La - EXTENDED ACTUATOR length

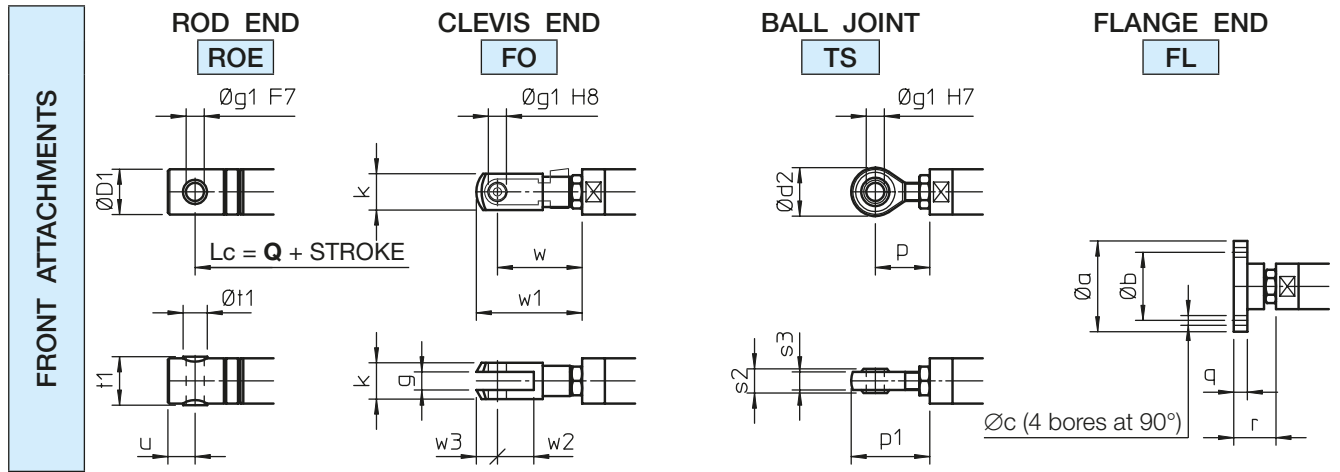
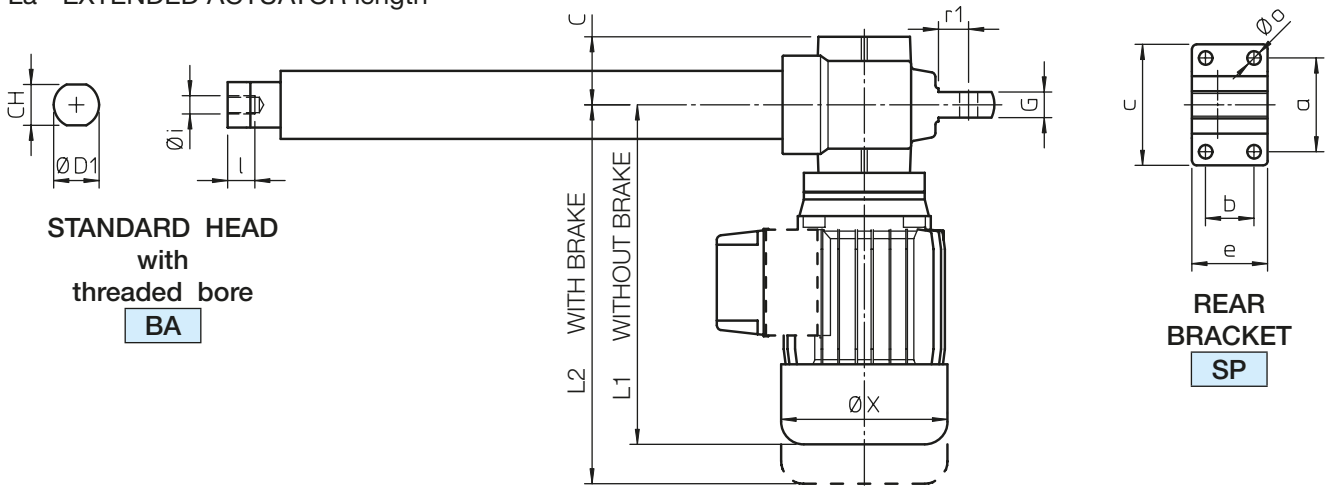

ELECTRIC STROKE LIMIT DEVICE FCE

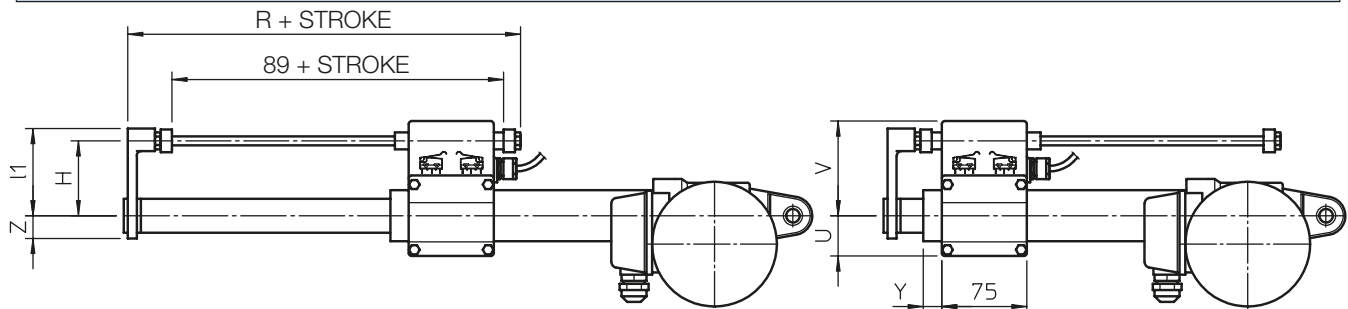

Linear actuators ATL Series

ACME SCREW LINEAR ACTUATORS ATL Series, size 20 – 25 – 28 – 30 – 40
AC 3-phase or 1-phase MOTOR – with Electric Stroke Limit Device FCE

STANDARD STROKE LENGTHS

	STROKE CODE	C100	C200	C300	C400	C500	C600	C700	C800	S	T	Q
ATL 20	STROKE [mm]	100	200	300	400	500	600	700	800	183	152	198
ATL 25										190	155	207
ATL 28										190	155	207
ATL 30										218	180	238
ATL 40										275	225	300

NOTE: Different stroke lengths available on request. $L_a = L_c + \text{STROKE}$

For stroke lengths longer than 800 mm it is necessary to increase the guided length between push rod and outer tube to avoid axial backlash. Dimensions **S**, **T** and **Q** shall be considered increased by 200 mm for stroke lengths up to 1500 mm.

For stroke lengths longer than 1500 mm, please, contact SERVOMECH.

	A	B	B1	C	CH	∅ D1	∅ D2	∅ D3	G	H1	H2	I	L1	L2
ATL 20	69	54	110	45	22	25	36	65	17	50	80	25	225	251
ATL 25	69	54	110	45	27	30	45	65	17	50	80	25	225	251
ATL 28	69	54	115	45	27	30	45	65	17	60	87	25	251	287
ATL 30	76	62	115	50	30	35	55	78	20	60	92	30	255	291
ATL 40	104	78	124	57	36	40	60	92	24	50	115	40	284	373

	R1	∅ X	a	b	c	e	∅ g	h	∅ i	l	∅ o	r1	s	t
ATL 20	17	110	62	32	80	50	12	40	M10×1.5	17	9	20	11	8
ATL 25	17	110	62	32	80	50	12	40	M12×1.75	18	9	20	11	8
ATL 28	17	123	62	32	80	50	12	40	M12×1.75	18	9	20	11	8
ATL 30	18	123	72	38	90	58	14	45	M14×2	24	9	20	12	8
ATL 40	28	150	85	55	110	81	20	58	M20×1.5	27	11	32	15	15

FRONT ATTACHMENT Dimensions

	∅ a	∅ b	∅ c	∅ D1	∅ d2	g	∅ g1	k	p	p1
ATL 20	55	40	5.5	25	28	10	10	20	31	45
ATL 25	60	45	6.5	30	32	12	12	24	36	52
ATL 28	60	45	6.5	30	32	12	12	24	36	52
ATL 30	65	50	6.5	35	36	14	14	27	36	54
ATL 40	80	60	8.5	40	50	20	20	40	53	78

	q	r	s2	s3	t1	∅ t1	u	w	w1	w2	w3
ATL 20	8	27	14	11	26	14	15	49	61	20	12
ATL 25	9	28	16	12	32	16	18	56	70	24	14
ATL 28	9	28	16	12	32	16	18	56	70	24	14
ATL 30	9	32	19	14	36	18	21	65	81	28	16
ATL 40	10	42	25	18	42	25	27	90	115	40	25

ELECTRIC STROKE LIMIT DEVICE FCE Dimensions

	H	R	U	V	Y	Z	l1
ATL 20	62	144	30	80	20	18	72
ATL 25	67	146	35	85	16	20	77
ATL 28	67	146	35	85	16	20	77
ATL 30	71	147	38	90	15	23	82
ATL 40	75	163	43	93	17	25	85

Linear actuators ATL Series

ACME SCREW LINEAR ACTUATORS ATL Series, size 20 – 25 – 28 – 30 – 40
AC 3-phase or 1-phase MOTOR – with Magnetic Stroke Limit Switches FCM

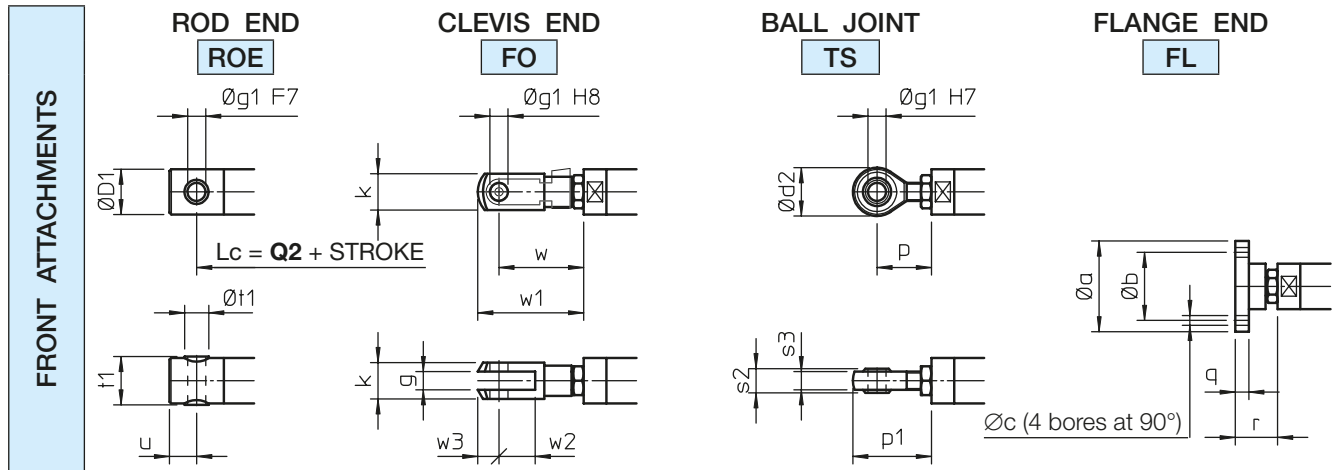
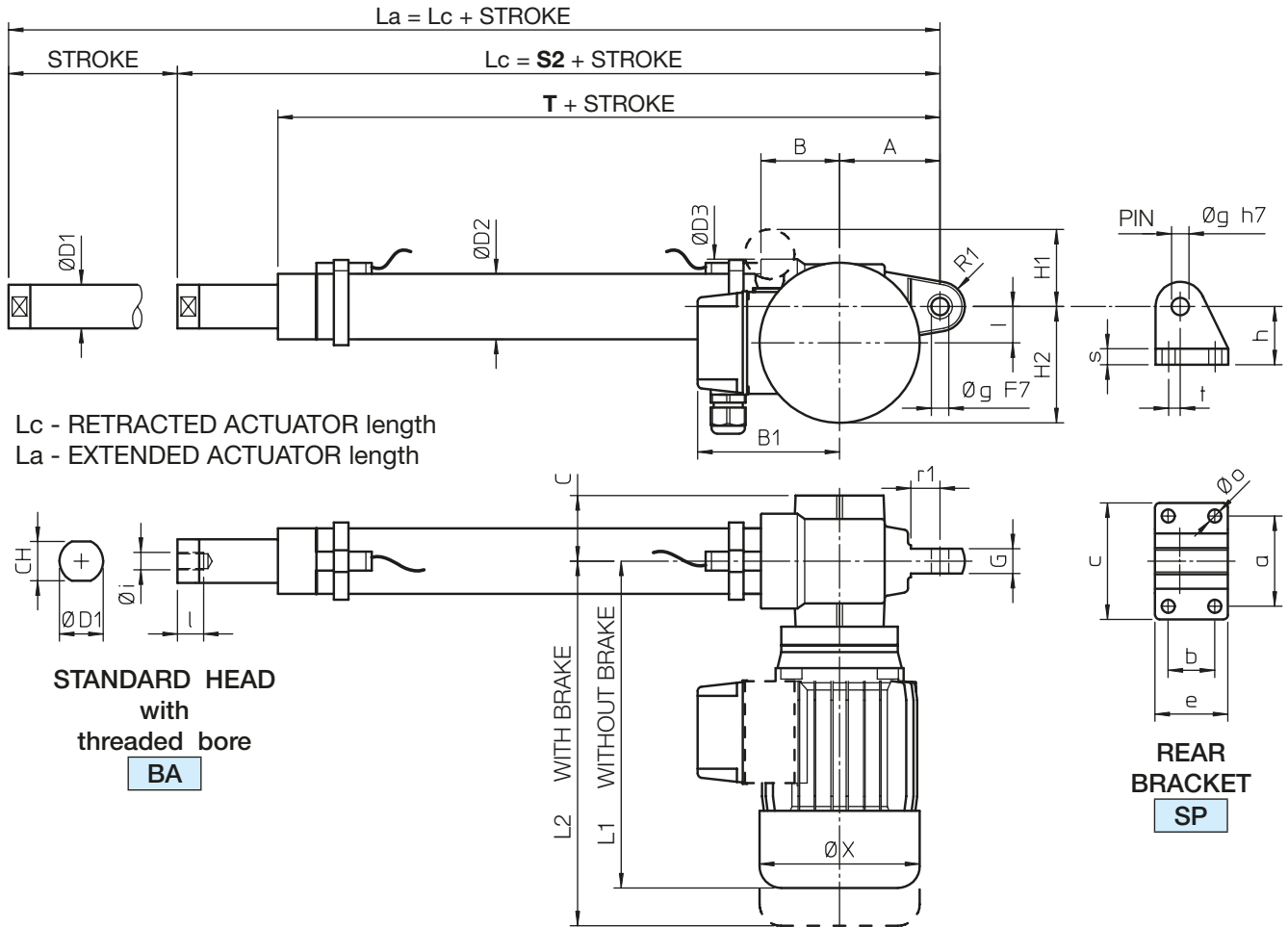

MAGNETIC STROKE LIMIT SWITCHES FCM Dimensions

	L	
	REED CONTACT NC or (NC+NO)	NO
ATL 20	18.5	23.5
ATL 25	26.5	31.5
ATL 28	26.5	31.5
ATL 30	29	34
ATL 40	35	40

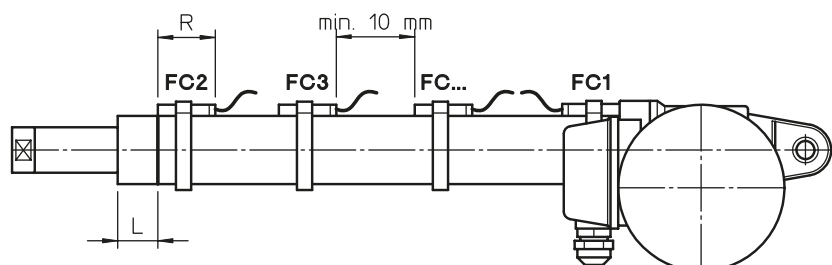

Linear actuators ATL Series

ACME SCREW LINEAR ACTUATORS ATL Series, size 20 – 25 – 28 – 30 – 40
AC 3-phase or 1-phase MOTOR – with Magnetic Stroke Limit Switches FCM

STANDARD STROKE LENGTHS

	STROKE CODE	C100	C200	C300	C400	C500	C600	C700	C800	S2	T	Q2
ATL 20	STROKE [mm]	72	172	272	372	472	572	672	772	235	180	235
ATL 25		66	166	266	366	466	566	666	766	252	189	255
ATL 28		66	166	266	366	466	566	666	766	252	189	255
ATL 30		68	168	268	368	468	568	668	768	276	212	282
ATL 40		63	163	263	363	463	563	663	763	339	262	351

NOTE: Different stroke lengths available on request. $L_a = L_c + \text{STROKE}$

For stroke lengths longer than 800 mm it is necessary to increase the guided length between push rod and outer tube to avoid axial backlash. Dimensions **S2**, **T** and **Q2** shall be considered increased by 200 mm for stroke lengths up to 1500 mm.

For stroke lengths longer than 1500 mm, please, contact SERVOMECH.

	A	B	B1	C	CH	∅ D1	∅ D2	∅ D3	G	H1	H2	I	L1	L2
ATL 20	69	54	110	45	22	25	36	65	17	50	80	25	225	251
ATL 25	69	54	110	45	27	30	45	65	17	50	80	25	225	251
ATL 28	69	54	115	45	27	30	45	65	17	60	87	25	251	287
ATL 30	76	62	115	50	30	35	55	78	20	60	92	30	255	291
ATL 40	104	78	124	57	36	40	60	92	24	50	115	40	284	373

	R1	∅ X	a	b	c	e	∅ g	h	∅ i	l	∅ o	r1	s	t
ATL 20	17	110	62	32	80	50	12	40	M10×1.5	17	9	20	11	8
ATL 25	17	110	62	32	80	50	12	40	M12×1.75	18	9	20	11	8
ATL 28	17	123	62	32	80	50	12	40	M12×1.75	18	9	20	11	8
ATL 30	18	123	72	38	90	58	14	45	M14×2	24	9	20	12	8
ATL 40	28	150	85	55	110	81	20	58	M20×1.5	27	11	32	15	15

FRONT ATTACHMENT Dimensions

	∅ a	∅ b	∅ c	∅ D1	∅ d2	g	∅ g1	k	p	p1
ATL 20	55	40	5.5	25	28	10	10	20	31	45
ATL 25	60	45	6.5	30	32	12	12	24	36	52
ATL 28	60	45	6.5	30	32	12	12	24	36	52
ATL 30	65	50	6.5	35	36	14	14	27	36	54
ATL 40	80	60	8.5	40	50	20	20	40	53	78

	q	r	s2	s3	t1	∅ t1	u	w	w1	w2	w3
ATL 20	8	27	14	11	26	14	15	49	61	20	12
ATL 25	9	28	16	12	32	16	18	56	70	24	14
ATL 28	9	28	16	12	32	16	18	56	70	24	14
ATL 30	9	32	19	14	36	18	21	65	81	28	16
ATL 40	10	42	25	18	42	25	27	90	115	40	25

MAGNETIC STROKE LIMIT SWITCHES FCM Technical features and dimensions

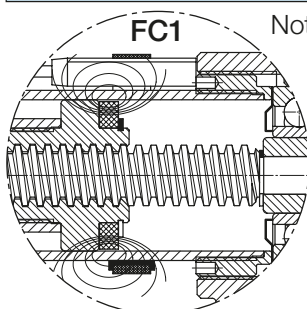

Note: - The travel length performed by an actuator with FCM is reduced if compared to the travel length of an actuator without FCM, because the REED SWITCH FC1 gives the stopping signal to the motor before the actuator reaches its minimum retracted length.

Therefore the actuator in retracted position is longer.

- Additional extra magnetic REED SWITCHES are available for intermediate positions.
- The minimum distance between the REED SWITCHES must be of at least 10 mm.
- REED SWITCH Normally Closed (NC) R = 39 mm
- REED SWITCH Change-over (NC+NO) R = 39 mm
- REED SWITCH Normally Open (NO) R = 29 mm

Linear actuators ATL Series

ACME SCREW LINEAR ACTUATORS ATL Series, size 20 – 25 – 30 – 40
 DC MOTOR – without stroke limit switches or with Electric Stroke Limit Device FCE

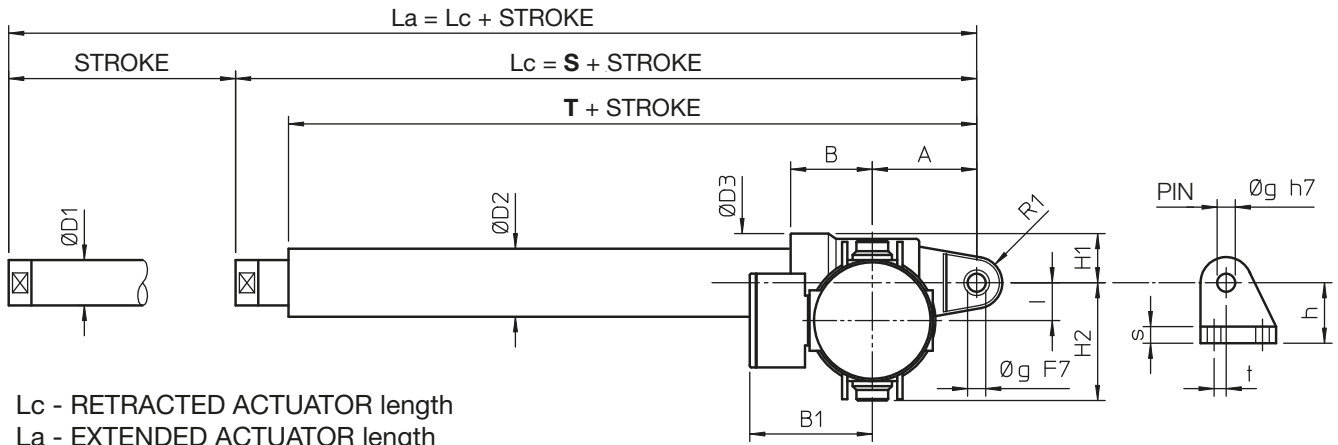

Lc - RETRACTED ACTUATOR length
 La - EXTENDED ACTUATOR length

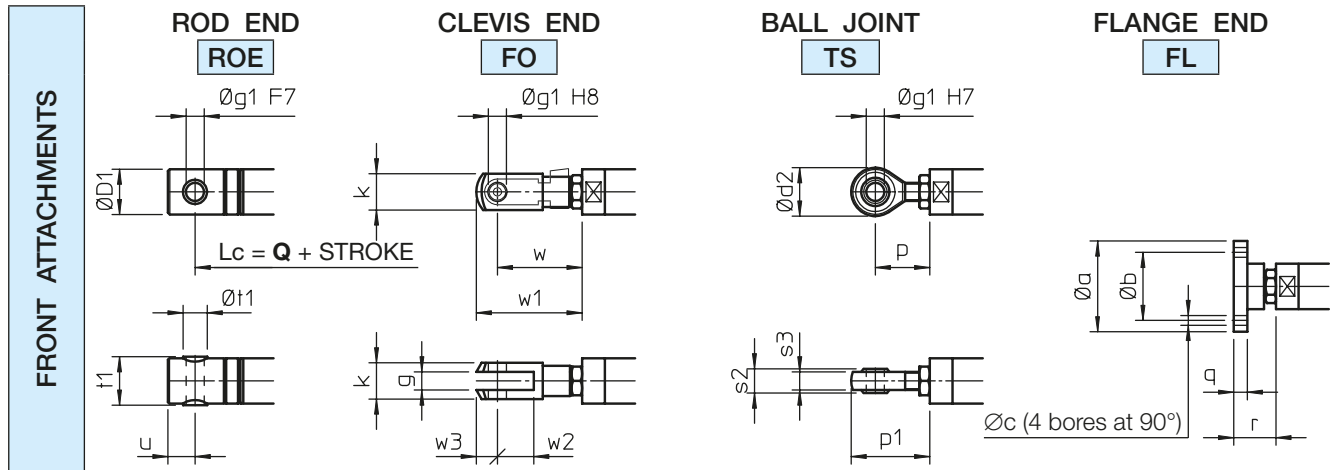
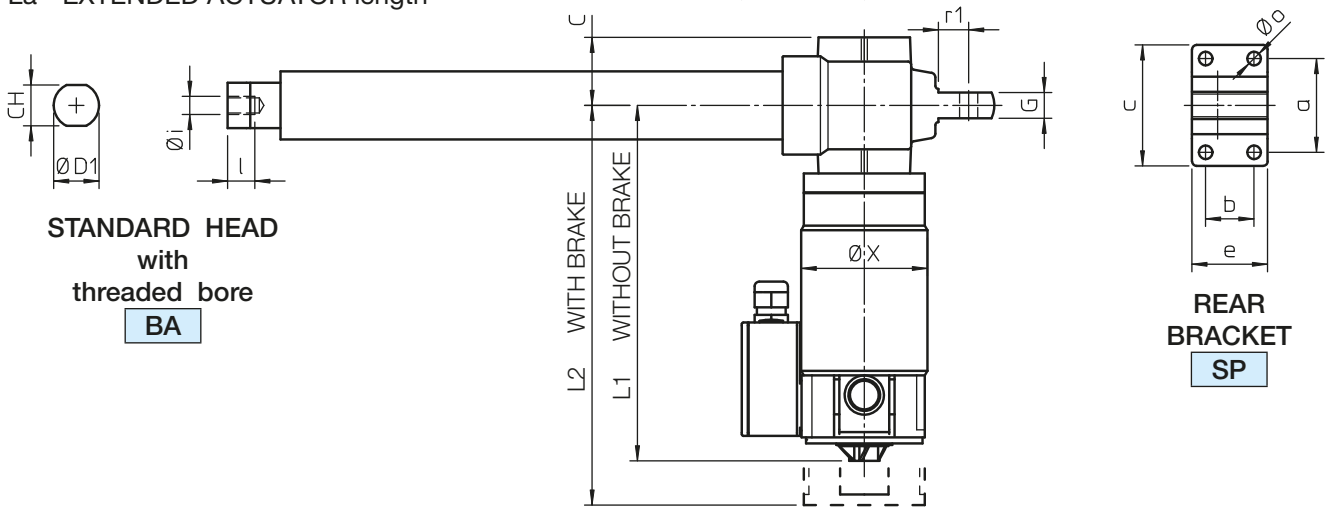

ELECTRIC STROKE LIMIT DEVICE FCE

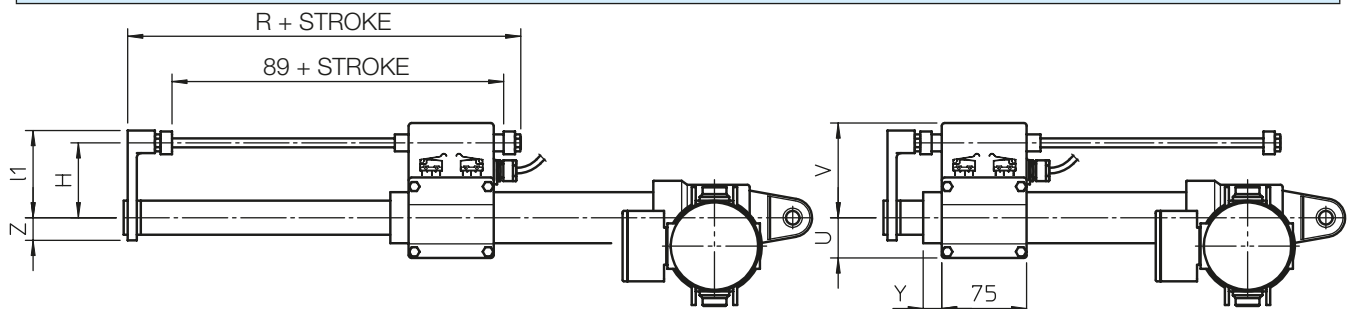

Linear actuators ATL Series

ACME SCREW LINEAR ACTUATORS ATL Series, size 20 – 25 – 30 – 40
DC MOTOR – without stroke limit switches or with Electric Stroke Limit Device FCE

STANDARD STROKE LENGTHS

	STROKE CODE	C100	C200	C300	C400	C500	C600	C700	C800	S	T	Q
ATL 20	STROKE [mm]	100	200	300	400	500	600	700	800	183	152	198
ATL 25										190	155	207
ATL 30										218	180	238
ATL 40										275	225	300

NOTE: Different stroke lengths available on request. $L_a = L_c + \text{STROKE}$

For stroke lengths longer than 800 mm it is necessary to increase the guided length between push rod and outer tube to avoid axial backlash. Dimensions **S**, **T** and **Q** shall be considered increased by 200 mm for stroke lengths up to 1500 mm.

For stroke lengths longer than 1500 mm, please, contact SERVOMECH.

	A	B	B1	C	CH	∅ D1	∅ D2	∅ D3	G	H1	H2	I	L1	L2
ATL 20	69	54	80	45	22	25	36	65	17	33	80	25	202	243
ATL 25	69	54	80	45	27	30	45	65	17	33	80	25	235	276
ATL 30	76	62	80	50	30	35	55	78	20	39	92	30	291	332
ATL 40	104	78	80	57	36	40	60	92	24	46	115	40	391	432

	R1	∅ X	a	b	c	e	∅ g	h	∅ i	l	∅ o	r1	s	t
ATL 20	17	107	62	32	80	50	12	40	M10×1.5	17	9	20	11	8
ATL 25	17	107	62	32	80	50	12	40	M12×1.75	18	9	20	11	8
ATL 30	18	107	72	38	90	58	14	45	M14×2	24	9	20	12	8
ATL 40	28	107	85	55	110	81	20	58	M20×1.5	27	11	32	15	15

FRONT ATTACHMENT Dimensions

	∅ a	∅ b	∅ c	∅ D1	∅ d2	g	∅ g1	k	p	p1
ATL 20	55	40	5.5	25	28	10	10	20	31	45
ATL 25	60	45	6.5	30	32	12	12	24	36	52
ATL 30	65	50	6.5	35	36	14	14	27	36	54
ATL 40	80	60	8.5	40	50	20	20	40	53	78

	q	r	s2	s3	t1	∅ t1	u	w	w1	w2	w3
ATL 20	8	27	14	11	26	14	15	49	61	20	12
ATL 25	9	28	16	12	32	16	18	56	70	24	14
ATL 30	9	32	19	14	36	18	21	65	81	28	16
ATL 40	10	42	25	18	42	25	27	90	115	40	25

ELECTRIC STROKE LIMIT DEVICE FCE Dimensions

	H	R	U	V	Y	Z	l1
ATL 20	62	144	30	80	20	18	72
ATL 25	67	146	35	85	16	20	77
ATL 30	71	147	38	90	15	23	82
ATL 40	75	163	43	93	17	25	85

Linear actuators ATL Series

ACME SCREW LINEAR ACTUATORS ATL Series, size 20 – 25 – 30 – 40
DC MOTOR – with Magnetic Stroke Limit Switches FCM

$$L_a = L_c + \text{STROKE}$$

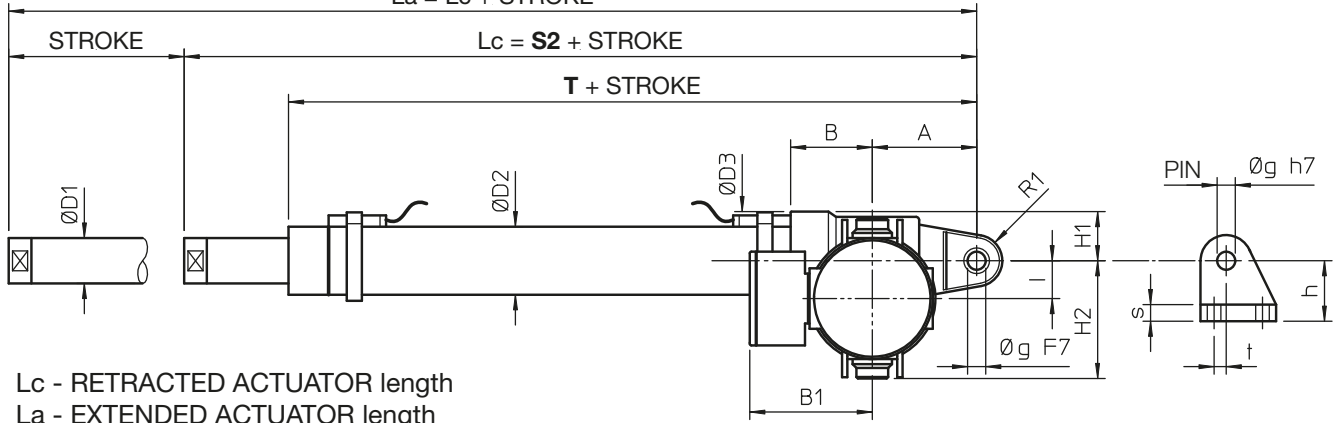

L_c - RETRACTED ACTUATOR length
 L_a - EXTENDED ACTUATOR length

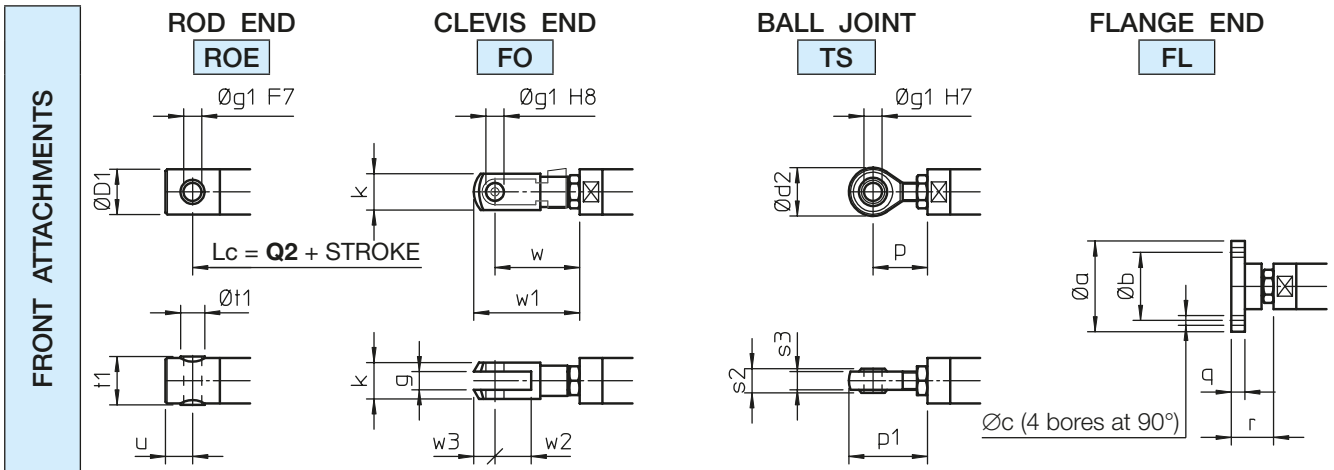
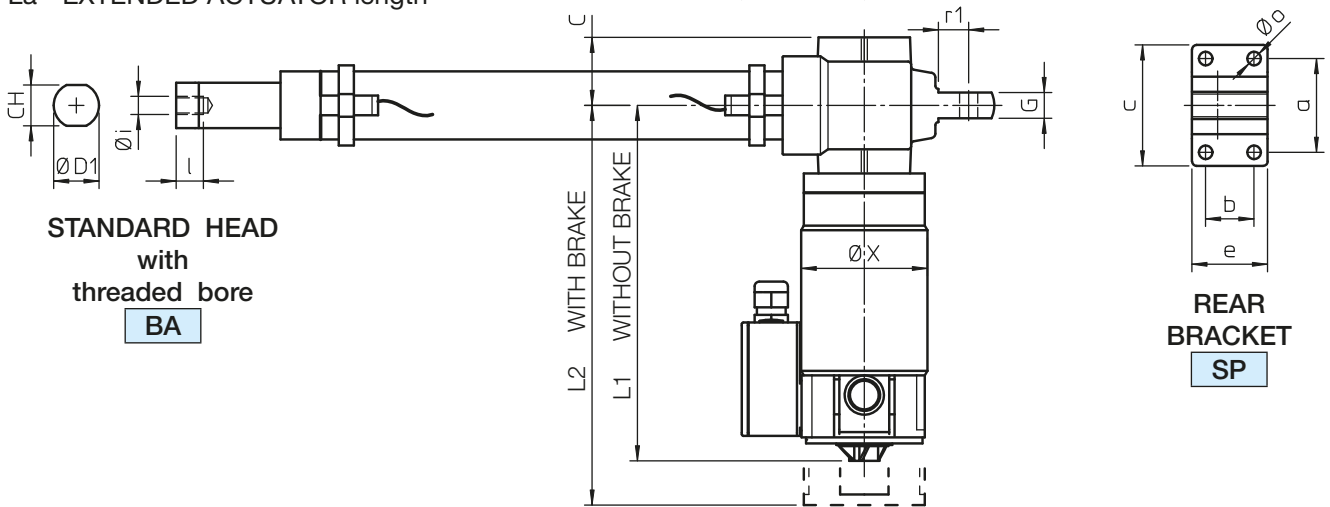

MAGNETIC STROKE LIMIT SWITCHES FCM Dimensions

	L	
	REED CONTACT NC or (NC+NO)	NO
ATL 20	18.5	23.5
ATL 25	26.5	31.5
ATL 28	26.5	31.5
ATL 30	29	34
ATL 40	35	40

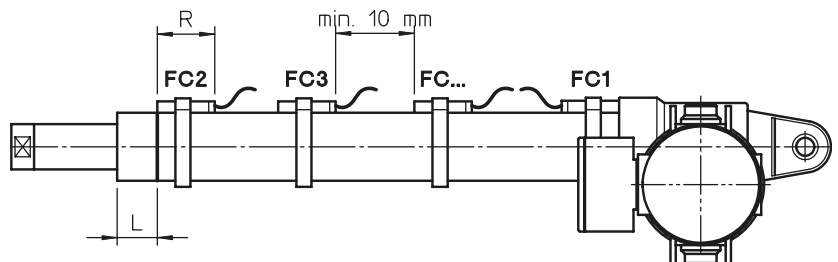

Linear actuators ATL Series

**ACME SCREW LINEAR ACTUATORS ATL Series, size 20 – 25 – 30 – 40
DC MOTOR – with Magnetic Stroke Limit Switches FCM**

STANDARD STROKE LENGTHS

	STROKE CODE	C100	C200	C300	C400	C500	C600	C700	C800	S2	T	Q2
ATL 20	STROKE [mm]	72	172	272	372	472	572	672	772	235	180	235
ATL 25		66	166	266	366	466	566	666	766	252	189	255
ATL 30		68	168	268	368	468	568	668	768	276	212	282
ATL 40		63	163	263	363	463	563	663	763	339	262	351

NOTE: Different stroke lengths available on request. $L_a = L_c + \text{STROKE}$

For stroke lengths longer than 800 mm it is necessary to increase the guided length between push rod and outer tube to avoid axial backlash. Dimensions **S2**, **T** and **Q2** shall be considered increased by 200 mm for stroke lengths up to 1500 mm.

For stroke lengths longer than 1500 mm, please, contact SERVOMECH.

	A	B	B1	C	CH	∅ D1	∅ D2	∅ D3	G	H1	H2	I	L1	L2
ATL 20	69	54	80	45	22	25	36	65	17	33	80	25	202	243
ATL 25	69	54	80	45	27	30	45	65	17	33	80	25	235	276
ATL 30	76	62	80	50	30	35	55	78	20	39	92	30	291	332
ATL 40	104	78	80	57	36	40	60	92	24	46	115	40	391	432

	R1	∅ X	a	b	c	e	∅ g	h	∅ i	l	∅ o	r1	s	t
ATL 20	17	107	62	32	80	50	12	40	M10×1.5	17	9	20	11	8
ATL 25	17	107	62	32	80	50	12	40	M12×1.75	18	9	20	11	8
ATL 30	18	107	72	38	90	58	14	45	M14×2	24	9	20	12	8
ATL 40	28	107	85	55	110	81	20	58	M20×1.5	27	11	32	15	15

FRONT ATTACHMENT Dimensions

	∅ a	∅ b	∅ c	∅ D1	∅ d2	g	∅ g1	k	p	p1
ATL 20	55	40	5.5	25	28	10	10	20	31	45
ATL 25	60	45	6.5	30	32	12	12	24	36	52
ATL 30	65	50	6.5	35	36	14	14	27	36	54
ATL 40	80	60	8.5	40	50	20	20	40	53	78

	q	r	s2	s3	t1	∅ t1	u	w	w1	w2	w3
ATL 20	8	27	14	11	26	14	15	49	61	20	12
ATL 25	9	28	16	12	32	16	18	56	70	24	14
ATL 30	9	32	19	14	36	18	21	65	81	28	16
ATL 40	10	42	25	18	42	25	27	90	115	40	25

MAGNETIC STROKE LIMIT SWITCHES FCM Technical features and dimensions

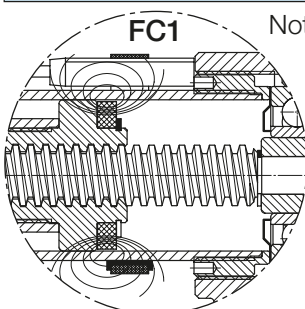

Note: - The travel length performed by an actuator with FCM is reduced if compared to the travel length of an actuator without FCM, because the REED SWITCH FC1 gives the stopping signal to the motor before the actuator reaches its minimum retracted length.

Therefore the actuator in retracted position is longer.

- Additional extra magnetic REED SWITCHES are available for intermediate positions.
- The minimum distance between the REED SWITCHES must be of at least 10 mm.
- REED SWITCH Normally Closed (NC) R = 39 mm
- REED SWITCH Change-over (NC+NO) R = 39 mm
- REED SWITCH Normally Open (NO) R = 29 mm

Linear actuators ATL Series

ACME SCREW LINEAR ACTUATORS ATL Series, size 50 – 63 – 80
AC 3-phase MOTOR – with Electric Stroke Limit Device FCE

2

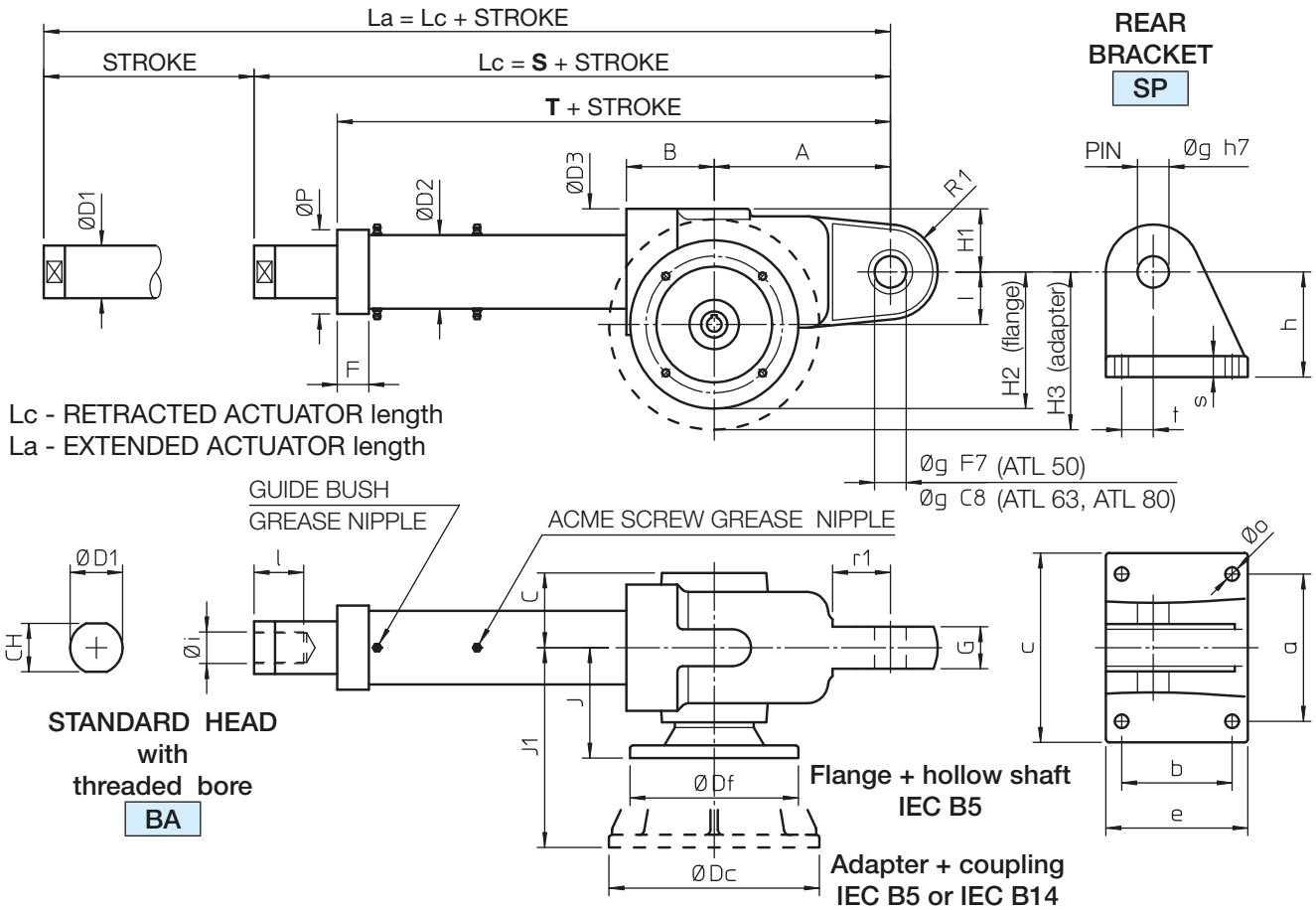

FRONT ATTACHMENTS

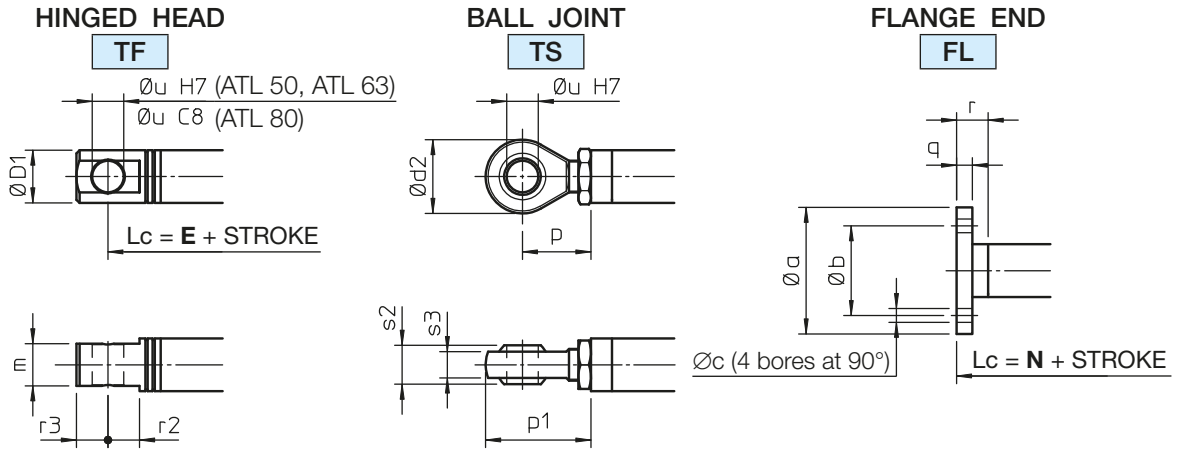

ELECTRIC STROKE LIMIT DEVICE FCE

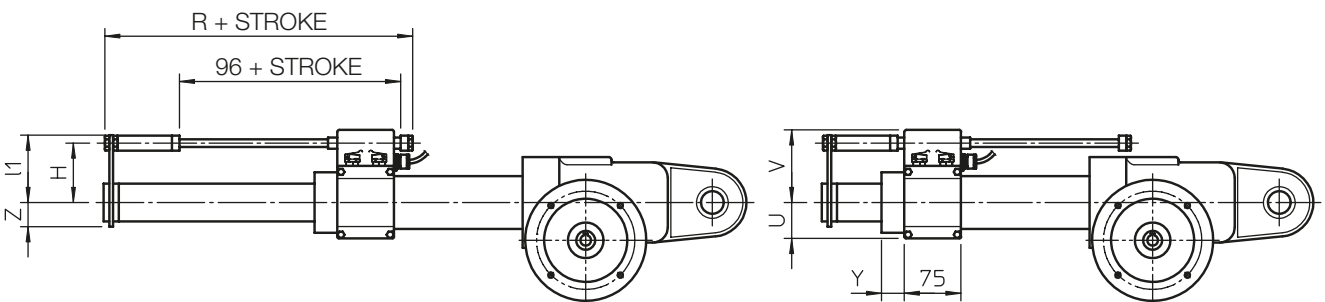

Linear actuators ATL Series

ACME SCREW LINEAR ACTUATORS ATL Series, size 50 – 63 – 80
AC 3-phase MOTOR – with Electric Stroke Limit Device FCE

STANDARD STROKE LENGTHS

	STROKE CODE	C100	C200	C300	C400	C500	C600	C700	C800	S	T	E	N
ATL 50	STROKE [mm]	100	200	300	400	500	600	700	800	405	326	435	415
ATL 63										516	419	546	526
ATL 80										603 (653)*	509 (569)*	638 (688)*	623 (673)*

* - value in brackets refers to ATL 80 with AR; ATL 80 with AR not available with FCE

NOTE: Different stroke lengths available on request. $L_a = L_c + \text{STROKE}$

For stroke lengths longer than 800 mm it is necessary to increase the guided length between push rod and outer tube to avoid axial backlash. Dimensions **S**, **T**, **E** and **N** shall be considered increased by 200 mm for stroke lengths up to 1500 mm.

For stroke lengths longer than 1500 mm, please, contact SERVOMECH.

	A	B	C	CH	∅ D1	∅ D2	∅ D3	F	G	H1	I	∅ P	R1
ATL 50	168	83	68	46	50	70	120	—	40	63	50	—	45
ATL 63	206	96	83	—	60	90	140	37	50	70	63	95	50
ATL 80	240	119	103	—	90	115 (150)*	160	40	60	90	80	125 (150)*	60

* - value in brackets refers to ATL 80 with AR; ATL 80 with AR not available with FCE

	a	b	c	e	∅ g	h	∅ i	l	∅ o	r1	s	t
ATL 50	140	105	185	143	30	100	M30×2	45	13	55	20	30
ATL 63	180	120	228	160	35	120	M36×2	55	17	58	30	30
ATL 80	210	122	278	180	40	130	M42×2	65	21	62	35	32

	Flange IEC	∅ Df	H2	J	Adapter IEC	∅ Dc	H3	J1
ATL 50	63 B5	140	120	102	80 B14 – 80 B5	120 – 200	110 – 150	176 – 182
	71 B5	160	130	102	90 B14 – 90 B5	140 – 200	120 – 150	182
ATL 63	80 B5	200	163	100	90 B14 – 90 B5	140 – 200	133 – 163	200
					100 B14 – 100 B5	160 – 250	143 – 188	220
ATL 80	80 B5; 90 B5	200	180	119	112 B14 – 112 B5	160 – 250	160 – 205	240

FRONT ATTACHMENT Dimensions

	∅ a	∅ b	∅ c	∅ D1	∅ d2	m	p	p1
ATL 50	120	85	13	50	70	40	65	100
ATL 63	140	100	17	60	80	50	86	126
ATL 80	170	130	21	90	90	50	85	130

	q	r	r2	r3	s2	s3	∅ u
ATL 50	15	30	30	30	37	25	30
ATL 63	15	30	30	35	43	28	35
ATL 80	20	40	35	45	49	33	40

ELECTRIC STROKE LIMIT DEVICE FCE Dimensions

	H	R	U	V	Y	Z	l1
ATL 50	79	188	50	97	5	32	89
ATL 63	89	237	60	107	37	37	100
ATL 80 *	101	237	73	119	40	55	113

* - ATL 80 with AR not available with FCE

Linear actuators ATL Series

ACME SCREW LINEAR ACTUATORS ATL Series, size 50 – 63 – 80
AC 3-phase MOTOR – Proximity Stroke Limit Switches FCP

2

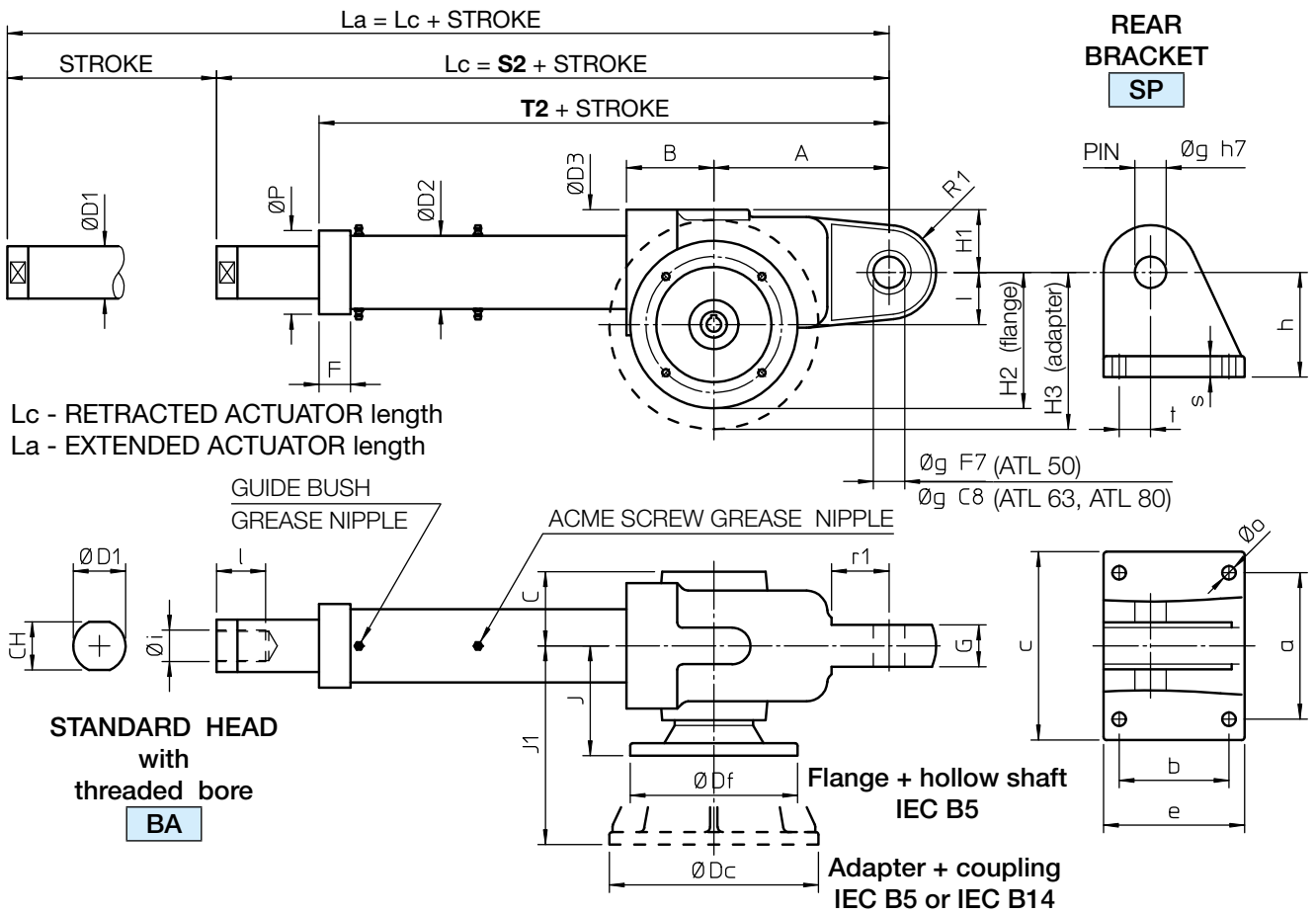

FRONT ATTACHMENTS

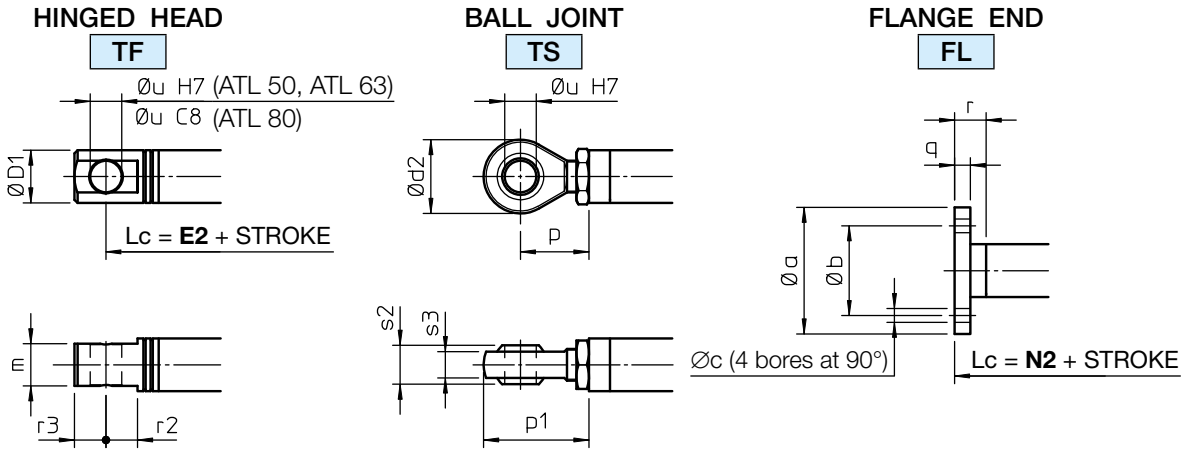

PROXIMITY STROKE LIMIT SWITCHES FCP Dimensions

	H	V	V1
ATL 50	79.5	263	15
ATL 63	86.5	314	40
ATL 80	99	371	40

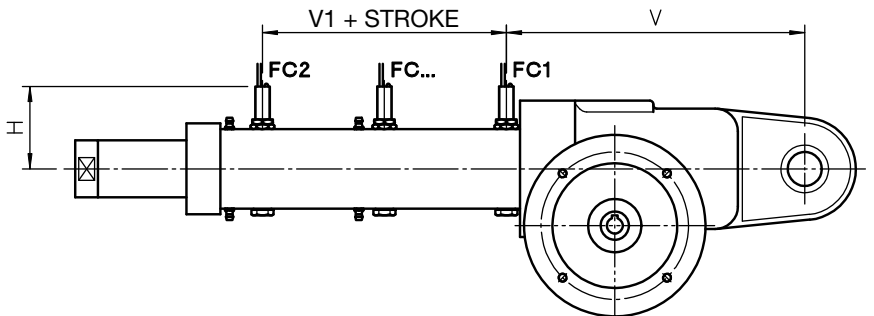

Linear actuators ATL Series

ACME SCREW LINEAR ACTUATORS ATL Series, size 50 – 63 – 80 AC 3-phase MOTOR – Proximity Stroke Limit Switches FCP STANDARD STROKE LENGTHS

	STROKE CODE	C100	C200	C300	C400	C500	C600	C700	C800	S2	T2	E2	N2
ATL 50	STROKE [mm]	100	200	300	400	500	600	700	800	443	345	473	453
ATL 63										554	438	584	564
ATL 80										647 (653)*	531 (569)*	682 (688)*	667 (673)*

* - value in brackets refers to ATL 80 with AR

NOTE: Different stroke lengths available on request. $L_a = L_c + \text{STROKE}$

For stroke lengths longer than 800 mm it is necessary to increase the guided length between push rod and outer tube to avoid axial backlash. Dimensions **S2**, **T2**, **E2** and **N2** shall be considered increased by 200 mm for stroke lengths up to 1500 mm.

For stroke lengths longer than 1500 mm, please, contact SERVOMECH.

	A	B	C	CH	∅ D1	∅ D2	∅ D3	F	G	H1	I	∅ P	R1
ATL 50	168	83	68	46	50	70	120	—	40	63	50	—	45
ATL 63	206	96	83	—	60	90	140	37	50	70	63	95	50
ATL 80	240	119	103	—	90	115 (150)*	160	40	60	90	80	125 (150)*	60

* - value in brackets refers to ATL 80 with AR

	a	b	c	e	∅ g	h	∅ i	l	∅ o	r1	s	t
ATL 50	140	105	185	143	30	100	M30×2	45	13	55	20	30
ATL 63	180	120	228	160	35	120	M36×2	55	17	58	30	30
ATL 80	210	122	278	180	40	130	M42×2	65	21	62	35	32

	Flange IEC	∅ Df	H2	J	Adapter IEC	∅ Dc	H3	J1
ATL 50	63 B5	140	120	102	80 B14 – 80 B5	120 – 200	110 – 150	176 – 182
	71 B5	160	130	102	90 B14 – 90 B5	140 – 200	120 – 150	182
ATL 63	80 B5	200	163	100	90 B14 – 90 B5	140 – 200	133 – 163	200
					100 B14 – 100 B5	160 – 250	143 – 188	220
ATL 80	80 B5; 90 B5	200	180	119	112 B14 – 112 B5	160 – 250	160 – 205	240

FRONT ATTACHMENT Dimensions

	∅ a	∅ b	∅ c	∅ D1	∅ d2	m	p	p1
ATL 50	120	85	13	50	70	40	65	100
ATL 63	140	100	17	60	80	50	86	126
ATL 80	170	130	21	90	90	50	85	130

	q	r	r2	r3	s2	s3	∅ u
ATL 50	15	30	30	30	37	25	30
ATL 63	15	30	30	35	43	28	35
ATL 80	20	40	35	45	49	33	40

PROXIMITY STROKE LIMIT SWITCHES FCP Technical features

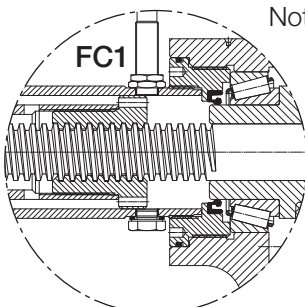

- Note: - The PROXIMITY SWITCH FC1, when activated, gives a signal to stop the motor by means of electric relays before the actuator reaches its minimal retracted length. The RETRACTED ACTUATOR LENGTH (L_c) and EXTENDED ACTUATOR LENGTH (L_a) of the actuator equipped with PROXIMITY SWITCHES FCP are longer than L_a and L_c of the actuator with electric stroke limit device FCE or without stroke end switches.
- Additional PROXIMITY SWITCHES are available for intermediate positions.
 - The minimum distance between the PROXIMITY SWITCHES must be of at least 25 mm.

Linear actuators ATL Series

ACME SCREW LINEAR ACTUATORS ATL Series, size 100 – 125
AC 3-phase MOTOR – with Electric Stroke End Switches FC

2

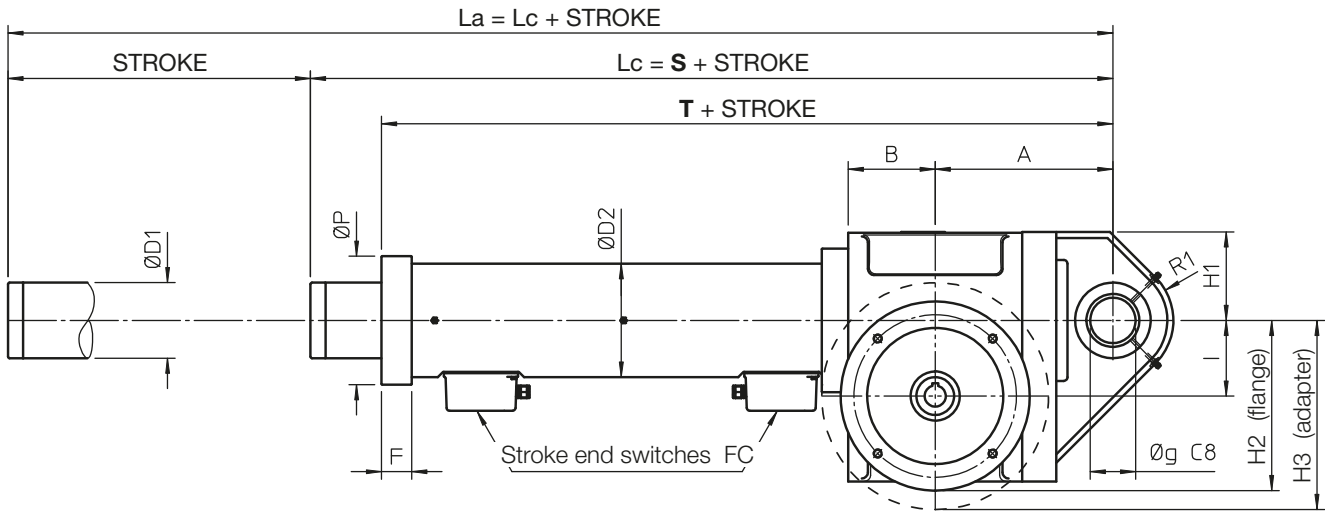

Lc - RETRACTED ACTUATOR length
La - EXTENDED ACTUATOR length

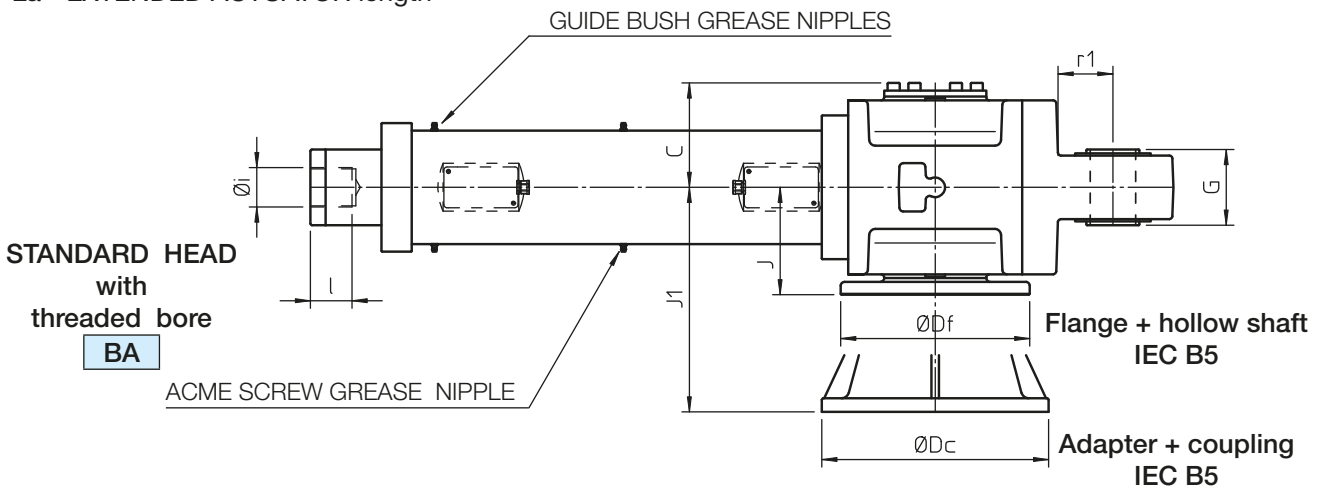

FRONT ATTACHMENTS

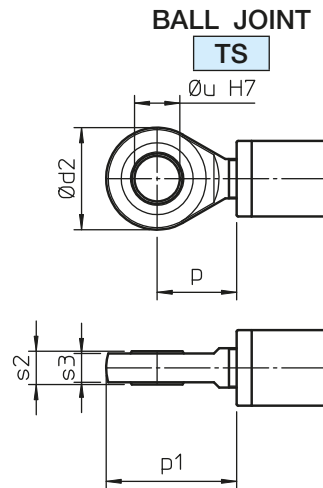
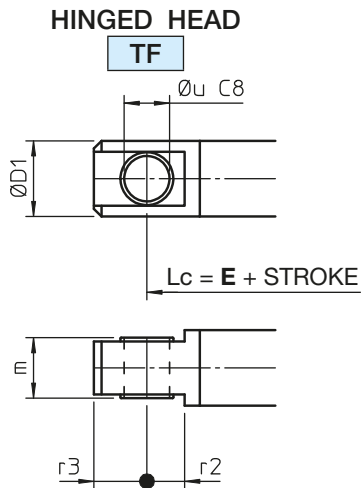

Linear actuators ATL Series

ACME SCREW LINEAR ACTUATORS ATL Series, size 100 – 125 AC 3-phase MOTOR – with Electric Stroke End Switches FC

	STROKE CODE	C...	S	T	E
ATL 100	STROKE [mm] = STROKE CODE	...	764	669	809
ATL 125			945	875	1030

NOTE: All stroke lengths are made on request.

For stroke lengths longer than 800 mm it is necessary to increase the guided length between push rod and outer tube to avoid axial backlash. Dimensions **S**, **T** and **E** shall be considered increased by 200 mm for stroke lengths up to 1500 mm.

For stroke lengths longer than 1500 mm please contact SERVOMECH.

	A	B	C	∅ D1	∅ D2	F	G	H1	I	∅ P	R1	∅ g	∅ i	l	r1
ATL 100	235	115	138	100	150	40	90	120	100	170	80	60	M60×4	60	72
ATL 125	320	140	173	150	200	—	100	335	125	—	90	80	M80×4	80	100

	Flange IEC	∅ Df	H2	J	Adapter IEC	∅ Dc	H3	J1
ATL 100	90 B5	200	225	142	132 B5	300	250	297
	100-112 B5	250	250	142				
ATL 125	—	—	—	—	132 B5	300	275	353
					160 B5	420	335	365

FRONT ATTACHMENT Dimensions

	∅ D1	∅ d2	m	p	p1	r2	r3	s2	s3	∅ u
ATL 100	100	135	70	95	163	50	70	44	38	60
ATL 125	150	180	100	130	220	80	80	55	47	80

Linear actuators BSA Series

BALL SCREW LINEAR ACTUATORS BSA Series, size 20 – 25 – 28 – 30 – 40
AC 3-phase or 1-phase MOTOR – with Electric Stroke Limit Device FCE

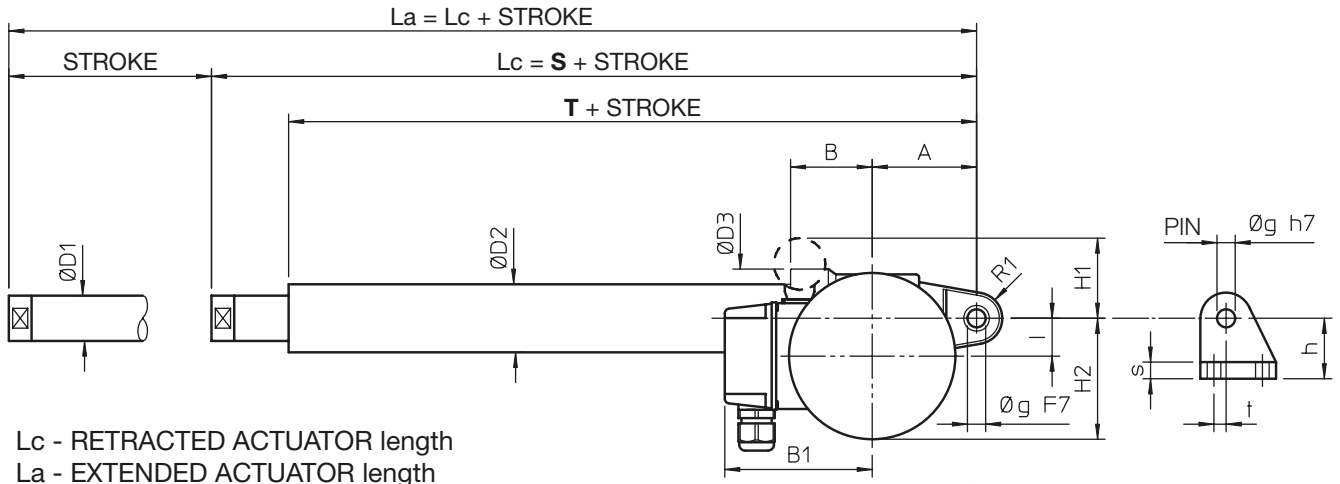

Lc - RETRACTED ACTUATOR length
La - EXTENDED ACTUATOR length

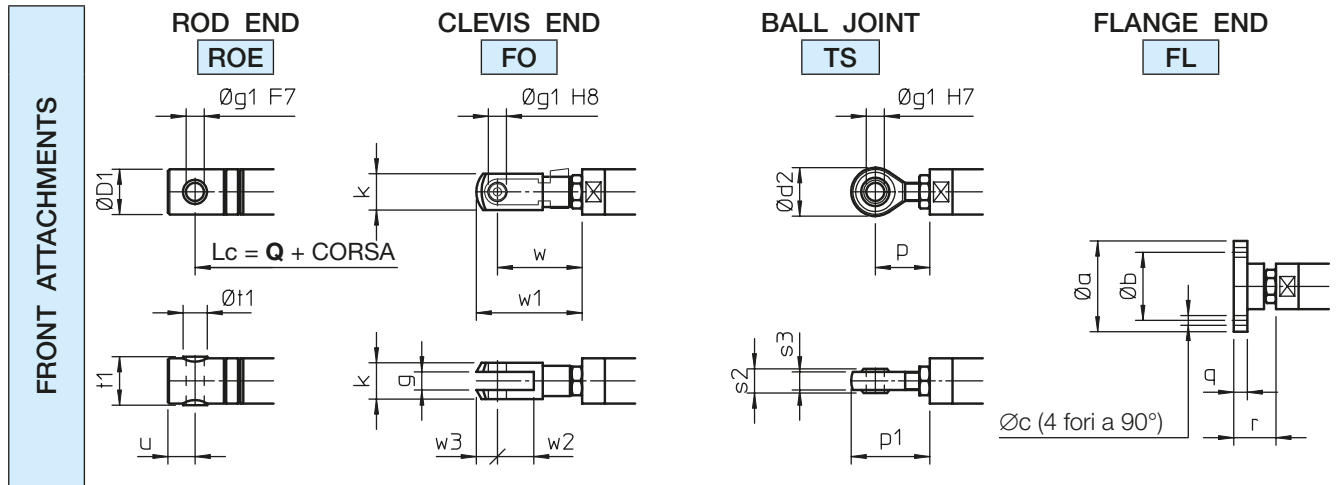
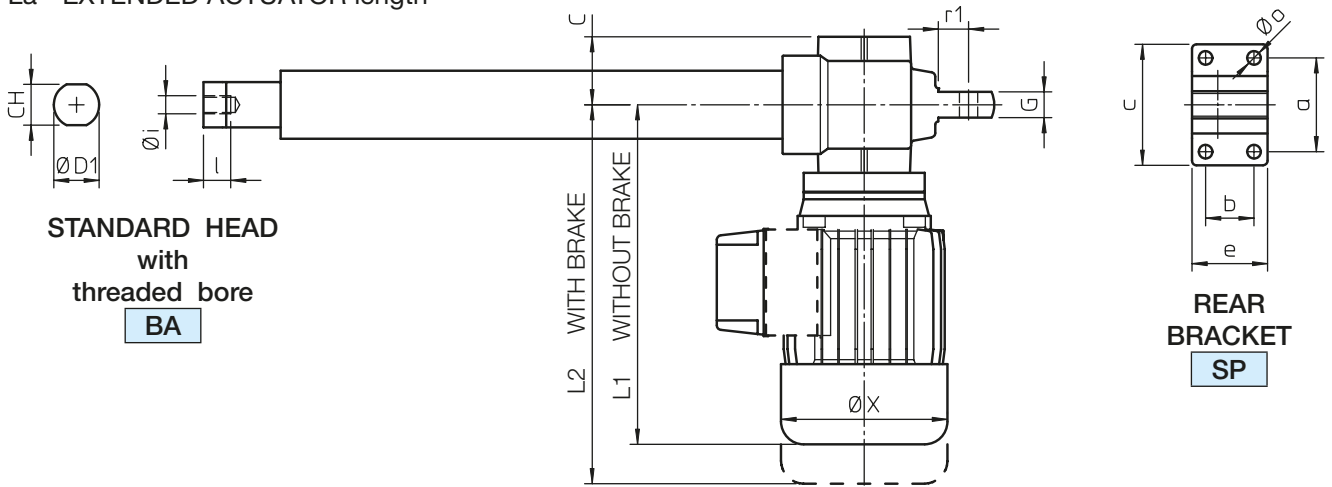

ELECTRIC STROKE LIMIT DEVICE FCE

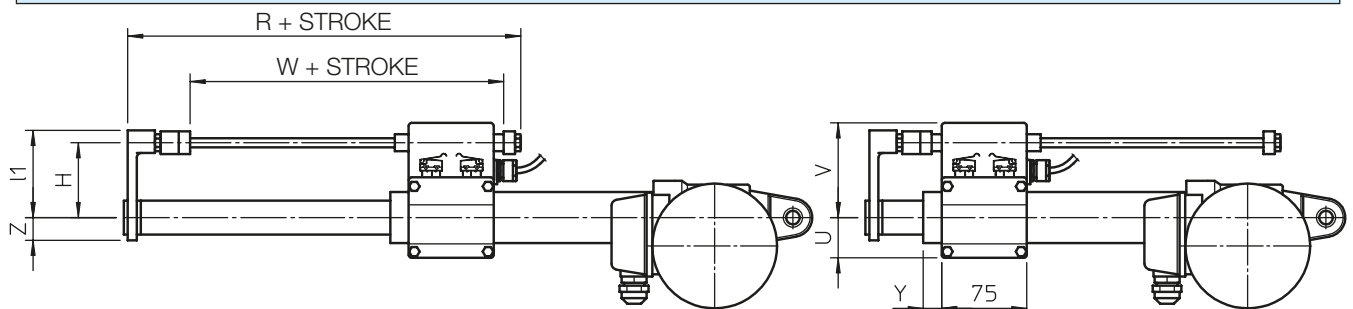

Linear actuators BSA Series

BALL SCREW LINEAR ACTUATORS BSA Series, size 20 – 25 – 28 – 30 – 40
AC 3-phase or 1-phase MOTOR – with Electric Stroke Limit Device FCE

STANDARD STROKE LENGTHS

	STROKE CODE	C100	C200	C300	C400	C500	C600	C700	C800	S	T	Q
BSA 20	STROKE [mm]	86	186	286	386	486	586	686	786	211	166	226
BSA 25		84	184	284	384	484	584	684	784	222	171	239
BSA 28		78	178	278	378	478	578	678	778	234	177	251
BSA 30		90	190	290	390	490	590	690	790	238	190	258
BSA 40		90	190	290	390	490	590	690	790	295	235	320

NOTE: Different stroke lengths available on request. $L_a = L_c + \text{STROKE}$

For stroke lengths longer than 800 mm it is necessary to increase the guided length between push rod and outer tube to avoid axial backlash. Dimensions **S**, **T** and **Q** shall be considered increased by 200 mm for stroke lengths up to 1500 mm.

For stroke lengths longer than 1500 mm, please, contact SERVOMECH.

	A	B	B1	C	CH	∅ D1	∅ D2	∅ D3	G	H1	H2	I	L1	L2
BSA 20	69	54	110	45	22	25	36	65	17	50	80	25	225	251
BSA 25	69	54	110	45	27	30	45	65	17	50	80	25	225	251
BSA 28	69	54	115	45	27	30	45	65	17	60	87	25	251	287
BSA 30	76	62	115	50	30	35	55	78	20	60	92	30	255	291
BSA 40	104	78	124	57	36	40	60	92	24	50	115	40	284	373

	R1	∅ X	a	b	c	e	∅ g	h	∅ i	l	∅ o	r1	s	t
BSA 20	17	110	62	32	80	50	12	40	M10×1.5	17	9	20	11	8
BSA 25	17	110	62	32	80	50	12	40	M12×1.75	18	9	20	11	8
BSA 28	17	123	62	32	80	50	12	40	M12×1.75	18	9	20	11	8
BSA 30	18	123	72	38	90	58	14	45	M14×2	24	9	20	12	8
BSA 40	28	150	85	55	110	81	20	58	M20×1.5	27	11	32	15	15

FRONT ATTACHMENT Dimensions

	∅ a	∅ b	∅ c	∅ D1	∅ d2	g	∅ g1	k	p	p1
BSA 20	55	40	5.5	25	28	10	10	20	31	45
BSA 25	60	45	6.5	30	32	12	12	24	36	52
BSA 28	60	45	6.5	30	32	12	12	24	36	52
BSA 30	65	50	6.5	35	36	14	14	27	36	54
BSA 40	80	60	8.5	40	50	20	20	40	53	78

	q	r	s2	s3	t1	∅ t1	u	w	w1	w2	w3
BSA 20	8	27	14	11	26	14	15	49	61	20	12
BSA 25	9	28	16	12	32	16	18	56	70	24	14
BSA 28	9	28	16	12	32	16	18	56	70	24	14
BSA 30	9	32	19	14	36	18	21	65	81	28	16
BSA 40	10	42	25	18	42	25	27	90	115	40	25

ELECTRIC STROKE LIMIT DEVICE FCE Dimensions

	H	R	U	V	W	Y	Z	l1
BSA 20	62	144	30	80	74	20	18	72
BSA 25	67	146	35	85	74	16	20	77
BSA 28	67	146	35	85	74	16	20	77
BSA 30	71	147	38	90	79	15	23	82
BSA 40	75	163	43	93	79	17	25	85

Linear actuators BSA Series

BALL SCREW LINEAR ACTUATORS BSA Series, size 20 – 25 – 28 – 30 – 40
AC 3-phase or 1-phase MOTOR – with Magnetic Stroke Limit Switches FCM

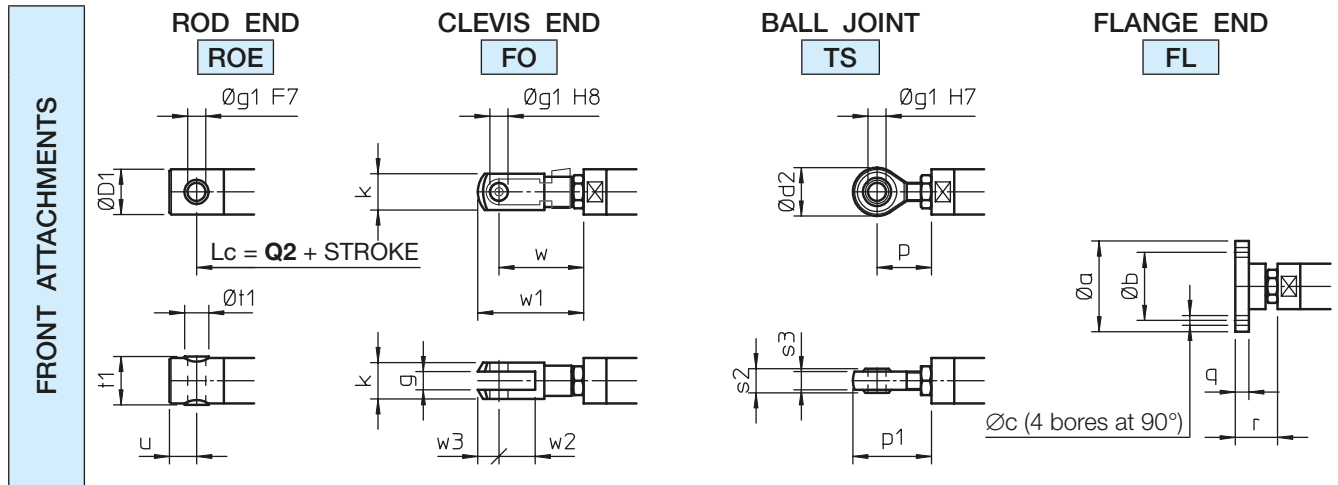
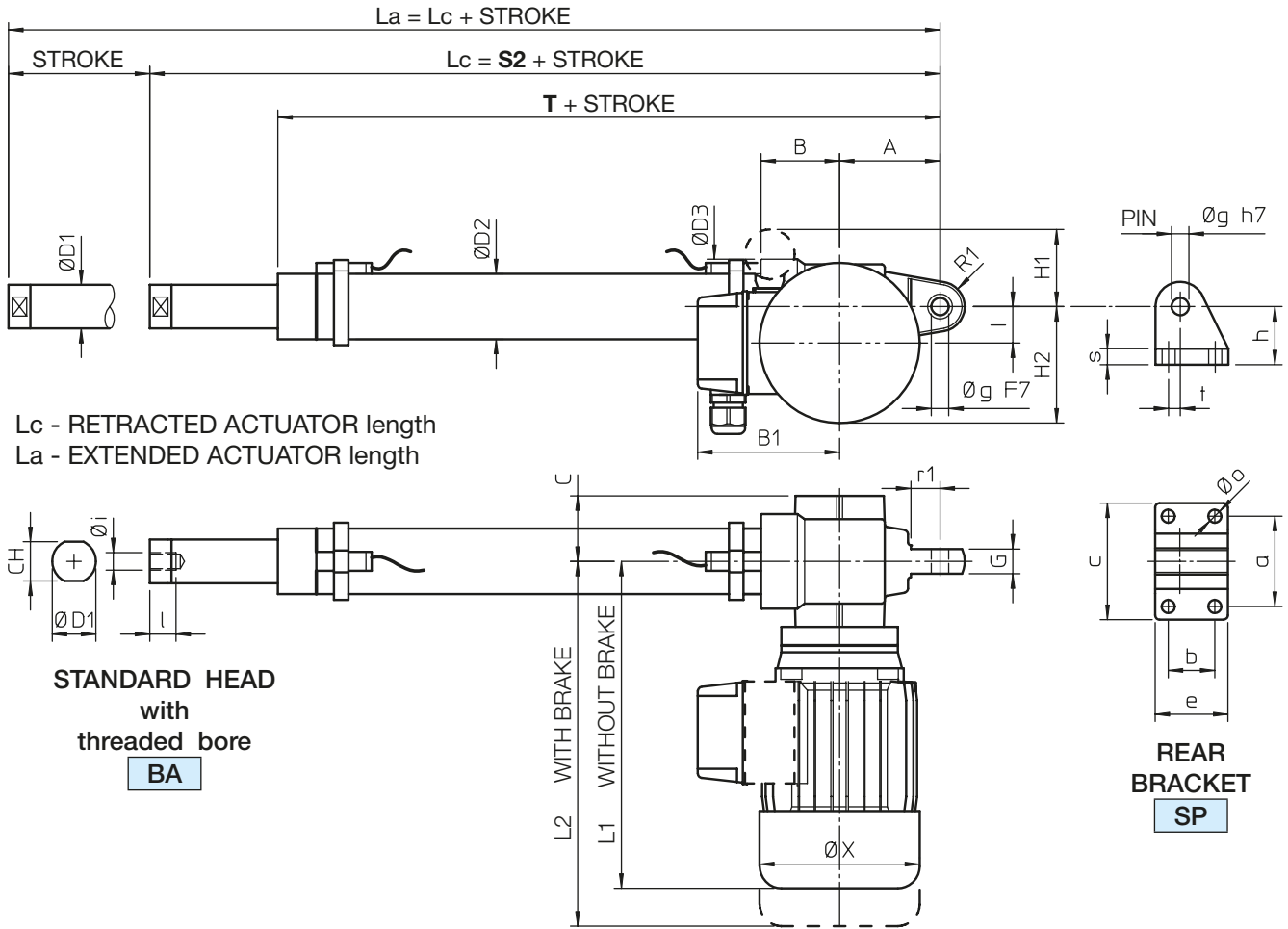

MAGNETIC STROKE LIMIT SWITCHES FCM Dimensions

	L	
	REED CONTACT NC or (NC+NO)	NO
BSA 20	18.5	23.5
BSA 25	26.5	31.5
BSA 28	26.5	31.5
BSA 30	29	34
BSA 40	35	40

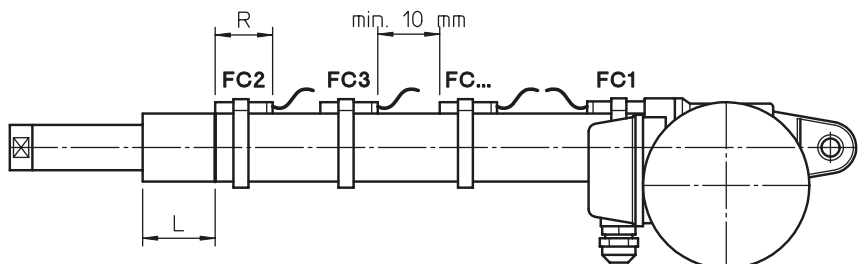

Linear actuators BSA Series

BALL SCREW LINEAR ACTUATORS BSA Series, size 20 – 25 – 28 – 30 – 40
AC 3-phase or 1-phase MOTOR – with Magnetic Stroke Limit Switches FCM

STANDARD STROKE LENGTHS

	STROKE CODE	C100	C200	C300	C400	C500	C600	C700	C800	S2	T	Q2
BSA 20	STROKE [mm]	54	154	254	354	454	554	654	754	275	198	275
BSA 25		47	147	247	347	447	547	647	747	296	208	299
BSA 28		41	141	241	341	441	541	641	741	308	214	311
BSA 30		46	146	246	346	446	546	646	746	326	234	332
BSA 40		37	137	237	337	437	537	637	737	401	288	413

NOTE: Different stroke lengths available on request. $L_a = L_c + \text{STROKE}$

For stroke lengths longer than 800 mm it is necessary to increase the guided length between push rod and outer tube to avoid axial backlash. Dimensions **S2**, **T** and **Q2** shall be considered increased by 200 mm for stroke lengths up to 1500 mm.

For stroke lengths longer than 1500 mm, please, contact SERVOMECH.

	A	B	B1	C	CH	Ø D1	Ø D2	Ø D3	G	H1	H2	I	L1	L2
BSA 20	69	54	110	45	22	25	36	65	17	50	80	25	225	251
BSA 25	69	54	110	45	27	30	45	65	17	50	80	25	225	251
BSA 28	69	54	115	45	27	30	45	65	17	60	87	25	251	287
BSA 30	76	62	115	50	30	35	55	78	20	60	92	30	255	291
BSA 40	104	78	124	57	36	40	60	92	24	50	115	40	284	373

	R1	Ø X	a	b	c	e	Ø g	h	Ø i	l	Ø o	r1	s	t
BSA 20	17	110	62	32	80	50	12	40	M10×1.5	17	9	20	11	8
BSA 25	17	110	62	32	80	50	12	40	M12×1.75	18	9	20	11	8
BSA 28	17	123	62	32	80	50	12	40	M12×1.75	18	9	20	11	8
BSA 30	18	123	72	38	90	58	14	45	M14×2	24	9	20	12	8
BSA 40	28	150	85	55	110	81	20	58	M20×1.5	27	11	32	15	15

FRONT ATTACHMENT Dimensions

	Ø a	Ø b	Ø c	Ø D1	Ø d2	g	Ø g1	k	p	p1
BSA 20	55	40	5.5	25	28	10	10	20	31	45
BSA 25	60	45	6.5	30	32	12	12	24	36	52
BSA 28	60	45	6.5	30	32	12	12	24	36	52
BSA 30	65	50	6.5	35	36	14	14	27	36	54
BSA 40	80	60	8.5	40	50	20	20	40	53	78

	q	r	s2	s3	t1	Ø t1	u	w	w1	w2	w3
BSA 20	8	27	14	11	26	14	15	49	61	20	12
BSA 25	9	28	16	12	32	16	18	56	70	24	14
BSA 28	9	28	16	12	32	16	18	56	70	24	14
BSA 30	9	32	19	14	36	18	21	65	81	28	16
BSA 40	10	42	25	18	42	25	27	90	115	40	25

FINECORSA MAGNETICI FCM - caratteristiche funzionali e dimensioni

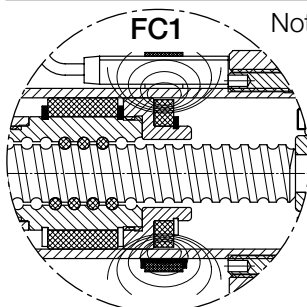

Note: - The travel length performed by an actuator with FCM is reduced if compared to the travel length of an actuator without FCM, because the REED SWITCH FC1 gives the stopping signal to the motor before the actuator reaches its minimum retracted length.

Therefore the actuator in retracted position is longer.

- Additional extra magnetic REED SWITCHES are available for intermediate positions.
- The minimum distance between the REED SWITCHES must be of at least 10 mm.
- REED SWITCH Normally Closed (NC) R = 39 mm
- REED SWITCH Change-over (NC+NO) R = 39 mm
- REED SWITCH Normally Open (NO) R = 29 mm

Linear actuators BSA Series

BALL SCREW LINEAR ACTUATORS BSA Series, size 20 – 25 – 30 – 40
 DC MOTOR – without stroke limit switches or with Electric Stroke Limit Device FCE

2

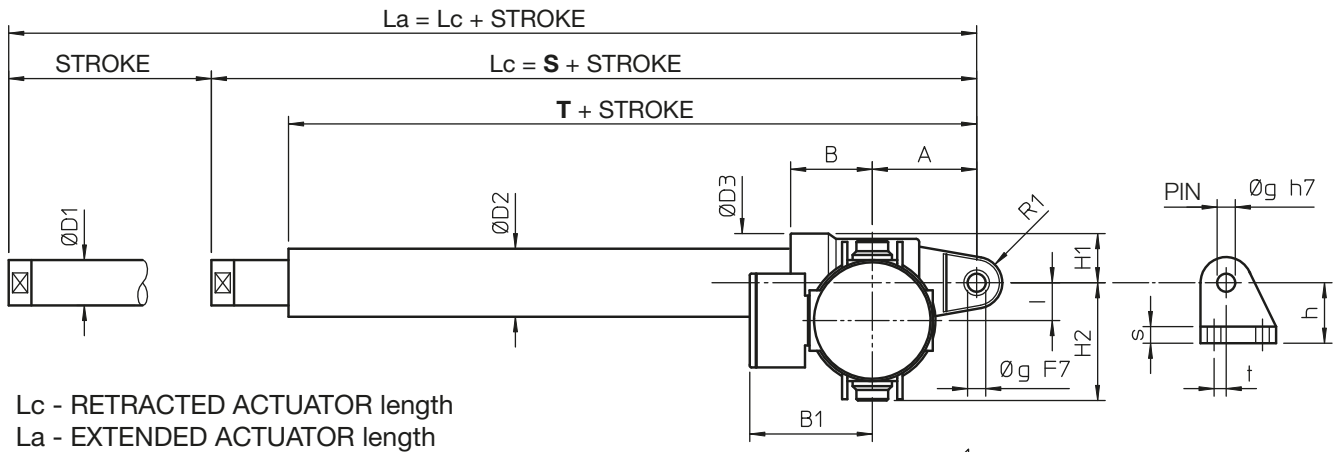

Lc - RETRACTED ACTUATOR length
 La - EXTENDED ACTUATOR length

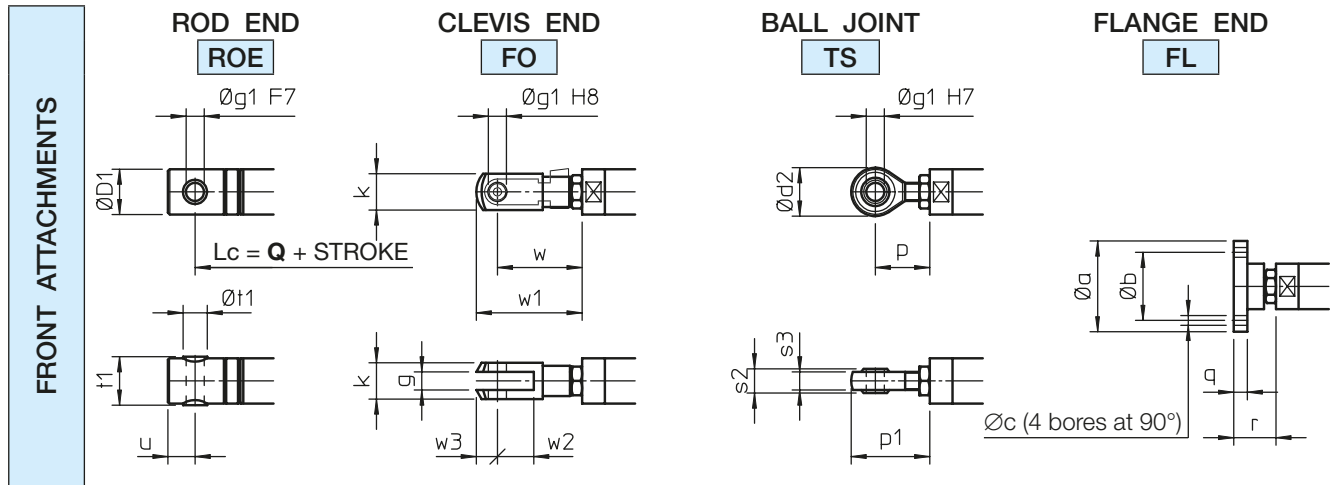
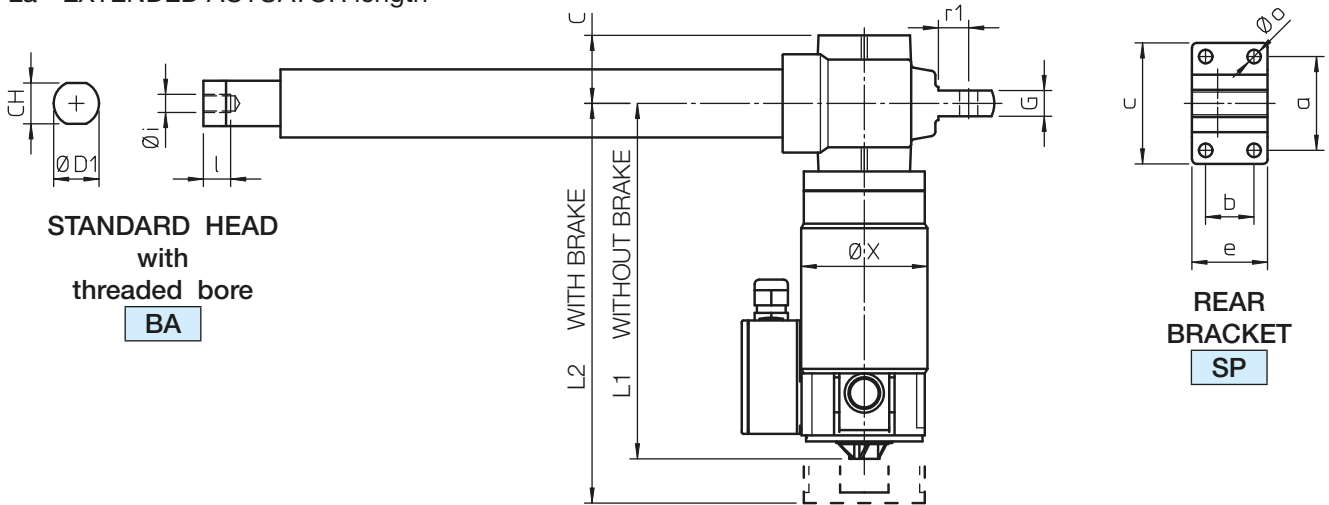

ELECTRIC STROKE LIMIT DEVICE FCE

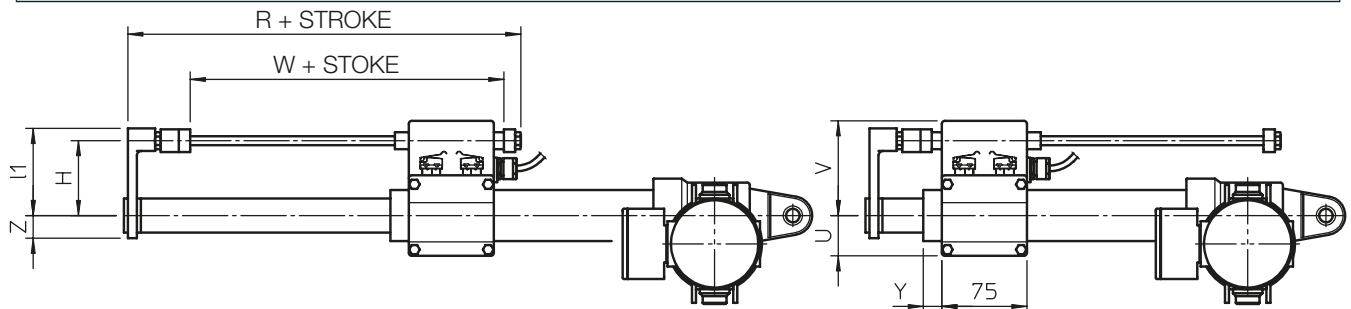

Linear actuators BSA Series

BALL SCREW LINEAR ACTUATORS BSA Series, size 20 – 25 – 30 – 40
DC MOTOR – without stroke limit switches or with Electric Stroke Limit Device FCE

STANDARD STROKE LENGTHS

	STROKE CODE	C100	C200	C300	C400	C500	C600	C700	C800		S	T	Q
BSA 20	STROKE [mm]	86	186	286	386	486	586	686	786		211	166	226
BSA 25		84	184	284	384	484	584	684	784		222	171	239
BSA 30		90	190	290	390	490	590	690	790		238	190	258
BSA 40		90	190	290	390	490	590	690	790		295	235	320

NOTE: Different stroke lengths available on request. $L_a = L_c + \text{STROKE}$

For stroke lengths longer than 800 mm it is necessary to increase the guided length between push rod and outer tube to avoid axial backlash. Dimensions **S**, **T** and **Q** shall be considered increased by 200 mm for stroke lengths up to 1500 mm.

For stroke lengths longer than 1500 mm, please, contact SERVOMECH.

	A	B	B1	C	CH	∅ D1	∅ D2	∅ D3	G	H1	H2	I	L1	L2
BSA 20	69	54	110	45	22	25	36	65	17	33	80	25	202	243
BSA 25	69	54	110	45	27	30	45	65	17	33	80	25	235	276
BSA 30	76	62	115	50	30	35	55	78	20	39	92	30	291	332
BSA 40	104	78	124	57	36	40	60	92	24	46	115	40	391	432

	R1	∅ X	a	b	c	e	∅ g	h	∅ i	l	∅ o	r1	s	t
BSA 20	17	110	62	32	80	50	12	40	M10×1.5	17	9	20	11	8
BSA 25	17	110	62	32	80	50	12	40	M12×1.75	18	9	20	11	8
BSA 30	18	123	72	38	90	58	14	45	M14×2	24	9	20	12	8
BSA 40	28	150	85	55	110	81	20	58	M20×1.5	27	11	32	15	15

FRONT ATTACHMENT Dimensions

	∅ a	∅ b	∅ c	∅ D1	∅ d2	g	∅ g1	k	p	p1
BSA 20	55	40	5.5	25	28	10	10	20	31	45
BSA 25	60	45	6.5	30	32	12	12	24	36	52
BSA 30	65	50	6.5	35	36	14	14	27	36	54
BSA 40	80	60	8.5	40	50	20	20	40	53	78

	q	r	s2	s3	t1	∅ t1	u	w	w1	w2	w3
BSA 20	8	27	14	11	26	14	15	49	61	20	12
BSA 25	9	28	16	12	32	16	18	56	70	24	14
BSA 30	9	32	19	14	36	18	21	65	81	28	16
BSA 40	10	42	25	18	42	25	27	90	115	40	25

ELECTRIC STROKE LIMIT DEVICE FCE Dimensions

	H	R	U	V	W	Y	Z	l1
BSA 20	62	144	30	80	74	20	18	72
BSA 25	67	146	35	85	74	16	20	77
BSA 30	71	147	38	90	79	15	23	82
BSA 40	75	163	43	93	79	17	25	85

Linear actuators BSA Series

BALL SCREW LINEAR ACTUATORS BSA Series, size 20 – 25 – 30 – 40
DC MOTOR – with Magnetic Stroke Limit Switches FCM

$$L_a = L_c + \text{STROKE}$$

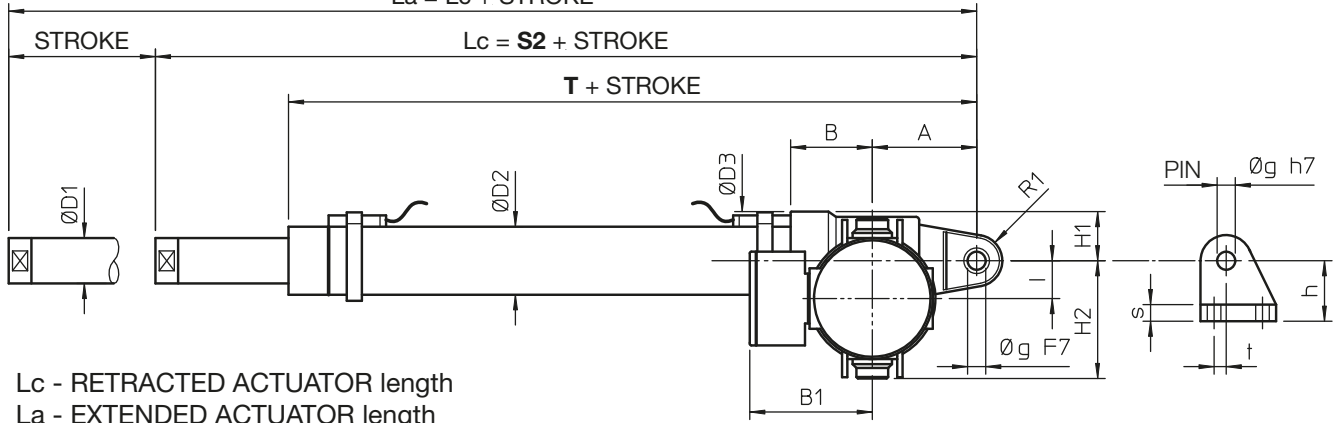

L_c - RETRACTED ACTUATOR length
 L_a - EXTENDED ACTUATOR length

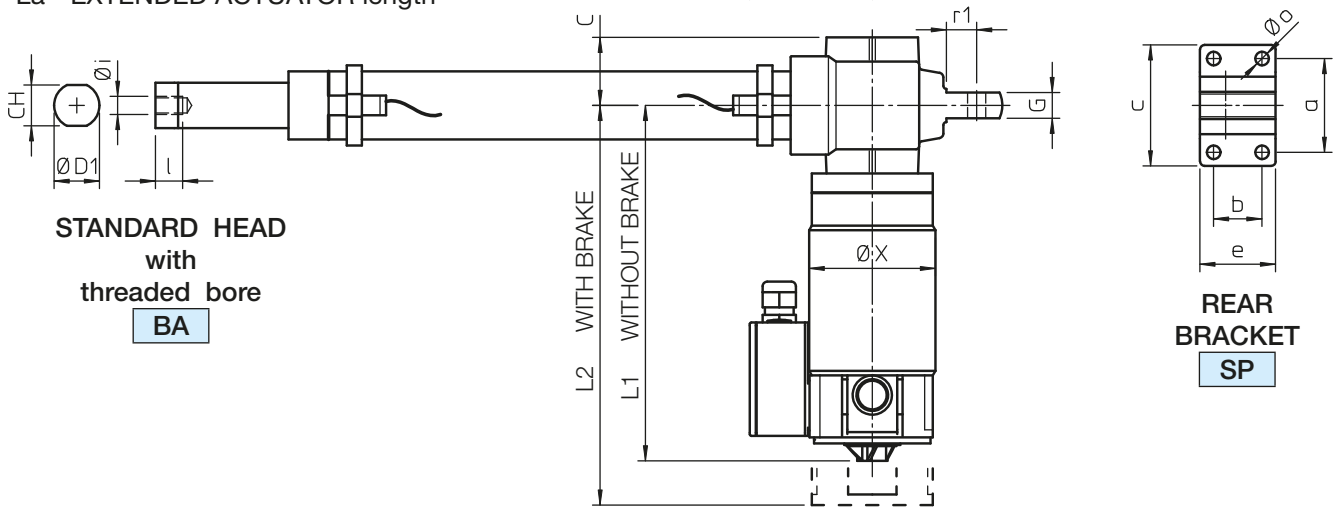

STANDARD HEAD
with
threaded bore

BA

REAR
BRACKET

SP

FRONT ATTACHMENTS

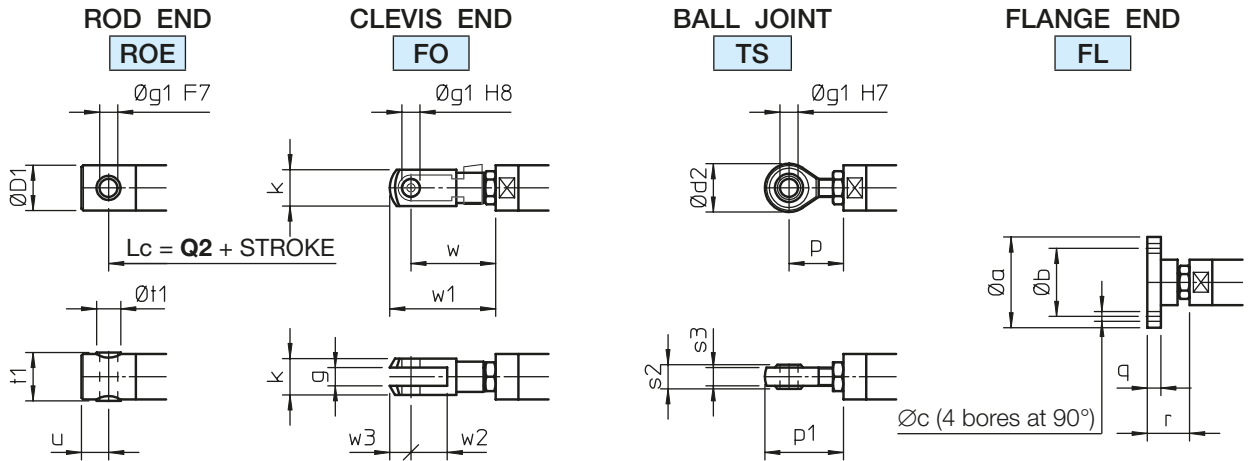

MAGNETIC STROKE LIMIT SWITCHES FCM Dimensions

	L	
	REED CONTACT NC or (NC+NO)	NO
BSA 20	18.5	23.5
BSA 25	26.5	31.5
BSA 28	26.5	31.5
BSA 30	29	34
BSA 40	35	40

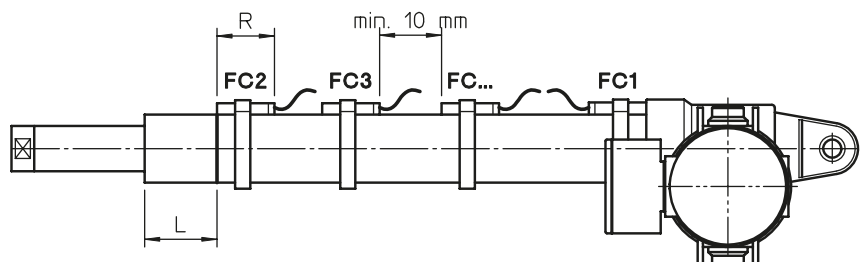

Linear actuators BSA Series

BALL SCREW LINEAR ACTUATORS BSA Series, size 20 – 25 – 30 – 40
DC MOTOR – with Magnetic Stroke Limit Switches FCM

STANDARD STROKE LENGTHS

	STROKE CODE	C100	C200	C300	C400	C500	C600	C700	C800	S2	T	Q2
BSA 20	STROKE [mm]	54	154	254	354	454	554	654	754	275	198	275
BSA 25		47	147	247	347	447	547	647	747	296	208	299
BSA 30		46	146	246	346	446	546	646	746	326	234	332
BSA 40		37	137	237	337	437	537	637	737	401	288	413

NOTE: Different stroke lengths available on request. $L_a = L_c + \text{STROKE}$

For stroke lengths longer than 800 mm it is necessary to increase the guided length between push rod and outer tube to avoid axial backlash. Dimensions **S2**, **T** and **Q2** shall be considered increased by 200 mm for stroke lengths up to 1500 mm.

For stroke lengths longer than 1500 mm, please, contact SERVOMECH.

	A	B	B1	C	CH	∅ D1	∅ D2	∅ D3	G	H1	H2	I	L1	L2
BSA 20	69	54	110	45	22	25	36	65	17	33	80	25	202	243
BSA 25	69	54	110	45	27	30	45	65	17	33	80	25	235	276
BSA 30	76	62	115	50	30	35	55	78	20	39	92	30	291	332
BSA 40	104	78	124	57	36	40	60	92	24	46	115	40	391	432

	R1	∅ X	a	b	c	e	∅ g	h	∅ i	l	∅ o	r1	s	t
BSA 20	17	110	62	32	80	50	12	40	M10×1.5	17	9	20	11	8
BSA 25	17	110	62	32	80	50	12	40	M12×1.75	18	9	20	11	8
BSA 30	18	123	72	38	90	58	14	45	M14×2	24	9	20	12	8
BSA 40	28	150	85	55	110	81	20	58	M20×1.5	27	11	32	15	15

FRONT ATTACHMENT Dimensions

	∅ a	∅ b	∅ c	∅ D1	∅ d2	g	∅ g1	k	p	p1
BSA 20	55	40	5.5	25	28	10	10	20	31	45
BSA 25	60	45	6.5	30	32	12	12	24	36	52
BSA 30	65	50	6.5	35	36	14	14	27	36	54
BSA 40	80	60	8.5	40	50	20	20	40	53	78

	q	r	s2	s3	t1	∅ t1	u	w	w1	w2	w3
BSA 20	8	27	14	11	26	14	15	49	61	20	12
BSA 25	9	28	16	12	32	16	18	56	70	24	14
BSA 30	9	32	19	14	36	18	21	65	81	28	16
BSA 40	10	42	25	18	42	25	27	90	115	40	25

MAGNETIC STROKE LIMIT SWITCHES FCM Technical features and dimensions

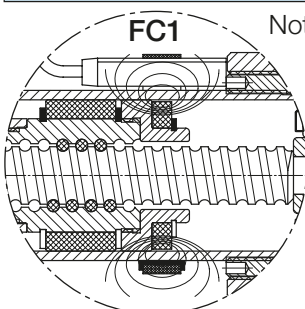

Note: - The travel length performed by an actuator with FCM is reduced if compared to the travel length of an actuator without FCM, because the REED SWITCH FC1 gives the stopping signal to the motor before the actuator reaches its minimum retracted length.

Therefore the actuator in retracted position is longer.

- Additional extra magnetic REED SWITCHES are available for intermediate positions.
- The minimum distance between the REED SWITCHES must be of at least 10 mm.
- REED SWITCH Normally Closed (NC) R = 39 mm
- REED SWITCH Change-over (NC+NO) R = 39 mm
- REED SWITCH Normally Open (NO) R = 29 mm

Linear actuators BSA Series

BALL SCREW LINEAR ACTUATORS BSA Series, size 50 – 63 – 80
AC 3-phase MOTOR – with Electric Stroke Limit Device FCE

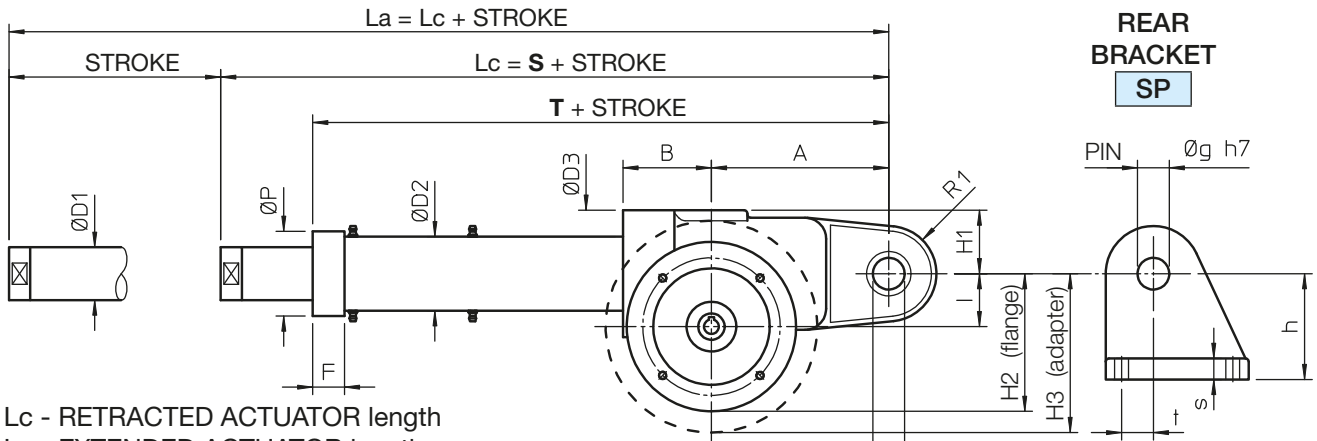

Lc - RETRACTED ACTUATOR length
 La - EXTENDED ACTUATOR length

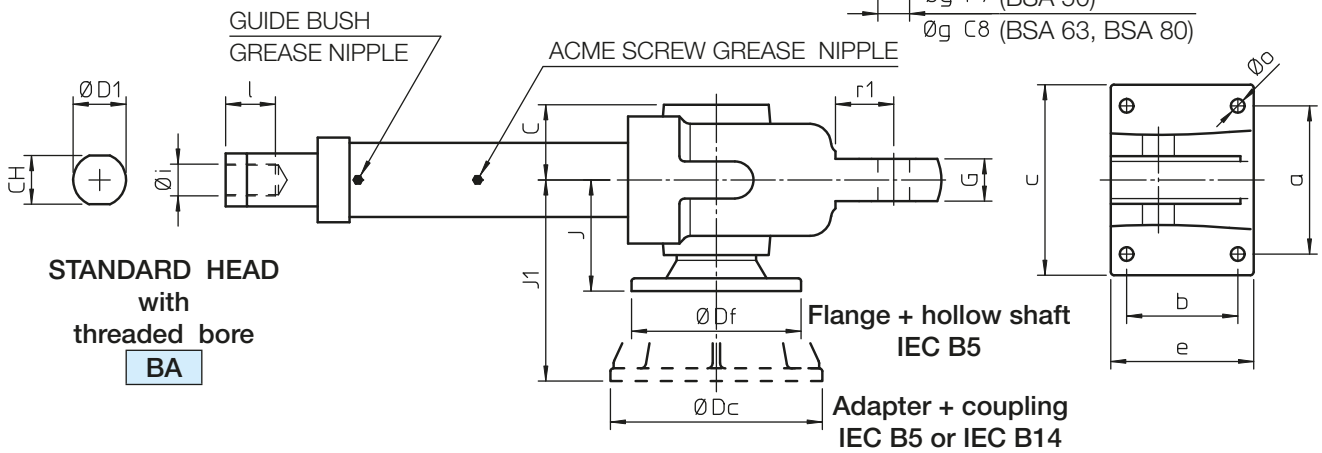

FRONT ATTACHMENTS

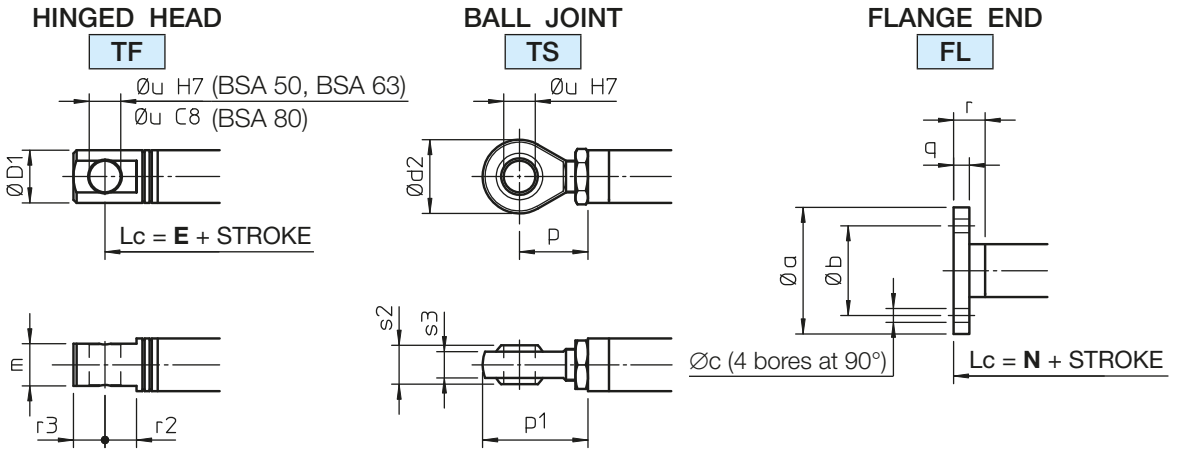

ELECTRIC STROKE LIMIT DEVICE FCE

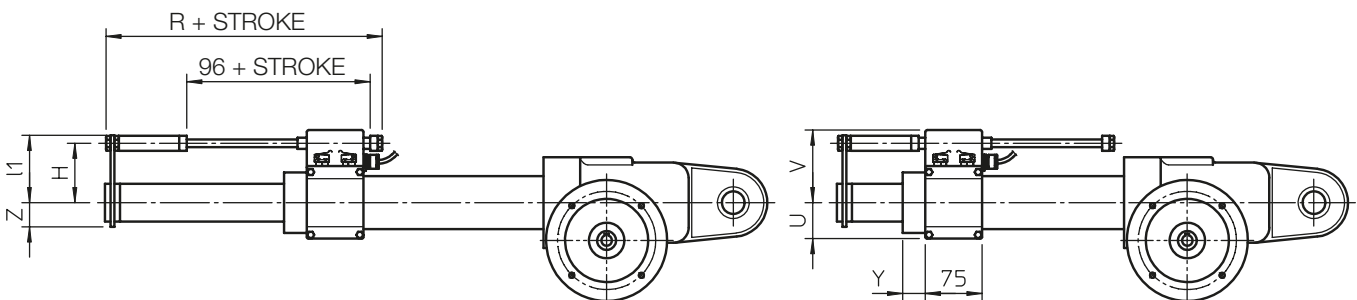

Linear actuators BSA Series

BALL SCREW LINEAR ACTUATORS BSA Series, size 50 – 63 – 80
AC 3-phase MOTOR – with Electric Stroke Limit Device FCE

STANDARD STROKE LENGTHS

	STROKE CODE	C100	C200	C300	C400	C500	C600	C700	C800	S	T	E	N
BSA 50										481	394	511	491
BSA 63	STROKE [mm]	100	200	300	400	500	600	700	800	571	467	601	581
BSA 80										673	576	708	693

NOTE: Different stroke lengths available on request. $L_a = L_c + \text{STROKE}$

For stroke lengths longer than 800 mm it is necessary to increase the guided length between push rod and outer tube to avoid axial backlash. Dimensions **S**, **T**, **E** and **N** shall be considered increased by 200 mm for stroke lengths up to 1500 mm.

For stroke lengths longer than 1500 mm, please, contact SERVOMECH.

	A	B	C	CH	∅ D1	∅ D2	∅ D3	F	G	H1	I	∅ P	R1
BSA 50	168	83	68	46	50	70	120	—	40	63	50	—	45
BSA 63	206	96	83	—	60	90	140	37	50	70	63	95	50
BSA 80	240	119	103	—	90	115	160	40	60	90	80	125	60

	a	b	c	e	∅ g	h	∅ i	l	∅ o	r1	s	t
BSA 50	140	105	185	143	30	100	M30×2	45	13	55	20	30
BSA 63	180	120	228	160	35	120	M36×2	55	17	58	30	30
BSA 80	210	122	278	180	40	130	M42×2	65	21	62	35	32

	Flange IEC	∅ Df	H2	J	Adapter IEC	∅ Dc	H3	J1
BSA 50	63 B5	140	120	102	80 B14 – 80 B5	120 – 200	110 – 150	176 – 182
	71 B5	160	130	102	90 B14 – 90 B5	140 – 200	120 – 150	182
BSA 63	80 B5	200	163	100	90 B14 – 90 B5	140 – 200	133 – 163	200
					100 B14 – 100 B5	160 – 250	143 – 188	220
BSA 80	80 B5; 90 B5	200	180	119	112 B14 – 112 B5	160 – 250	160 – 205	240

FRONT ATTACHMENT Dimensions

	∅ a	∅ b	∅ c	∅ D1	∅ d2	m	p
BSA 50	120	85	13	50	70	40	65
BSA 63	140	100	17	60	80	50	86
BSA 80	170	130	21	90	90	50	85

	p1	q	r	r2	r3	s2	s3	∅ u
BSA 50	100	15	30	30	30	37	25	30
BSA 63	126	15	30	30	35	43	28	35
BSA 80	130	20	40	35	45	49	33	40

ELECTRIC STROKE LIMIT DEVICE FCE Dimensions

	H	R	U	V	Y	Z	l1
BSA 50	79	188	50	97	5	32	89
BSA 63	89	237	60	107	37	37	100
BSA 80	101	237	73	119	40	55	113

Linear actuators BSA Series

BALL SCREW LINEAR ACTUATORS BSA Series, size 50 – 63 – 80
AC 3-phase MOTOR – Proximity Stroke Limit Switches FCP

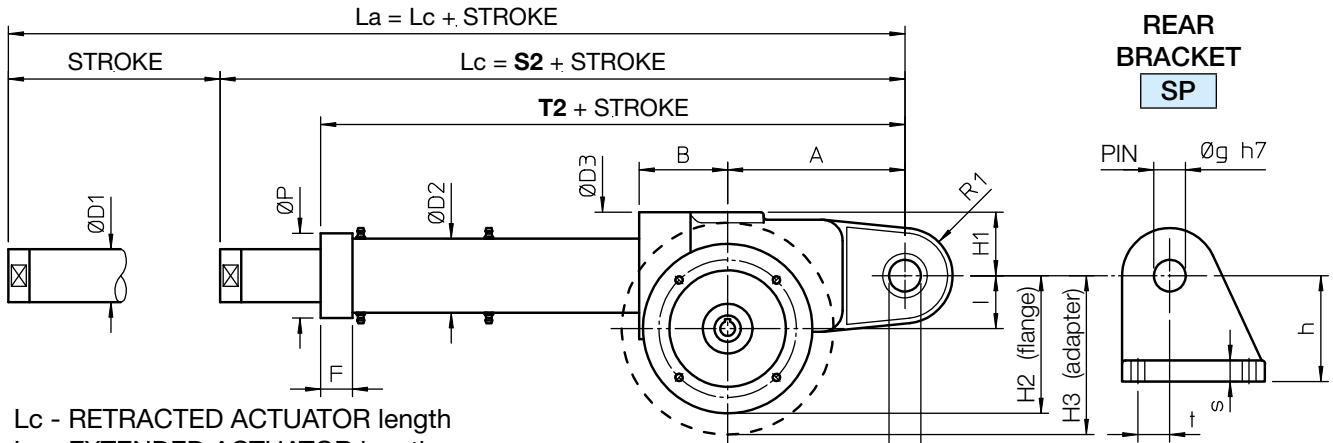

Lc - RETRACTED ACTUATOR length
La - EXTENDED ACTUATOR length

$\varnothing g$ F7 (BSA 50)
 $\varnothing g$ C8 (BSA 63, BSA 80)

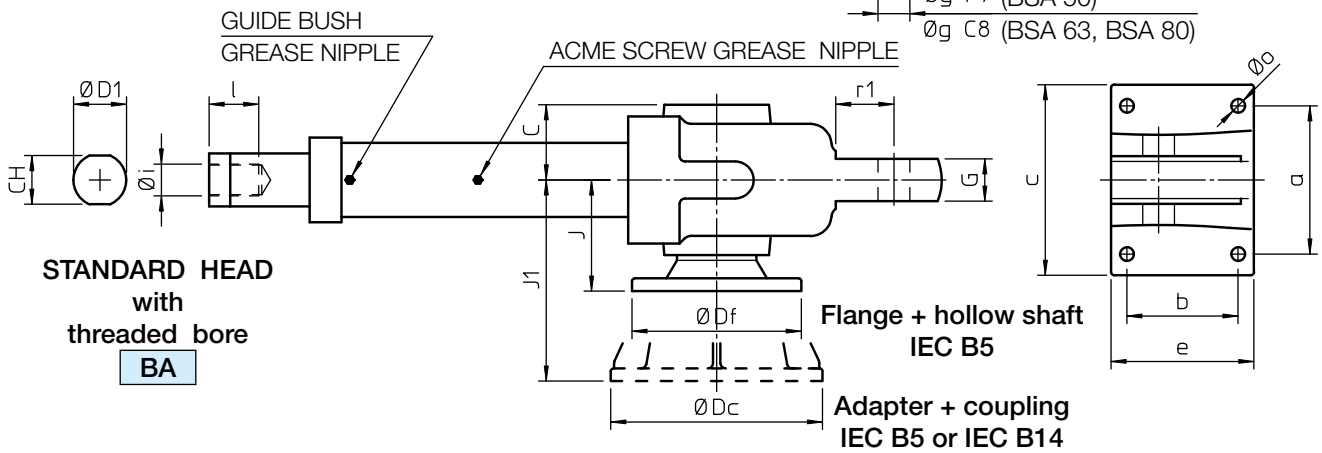

STANDARD HEAD with threaded bore
BA

FRONT ATTACHMENTS

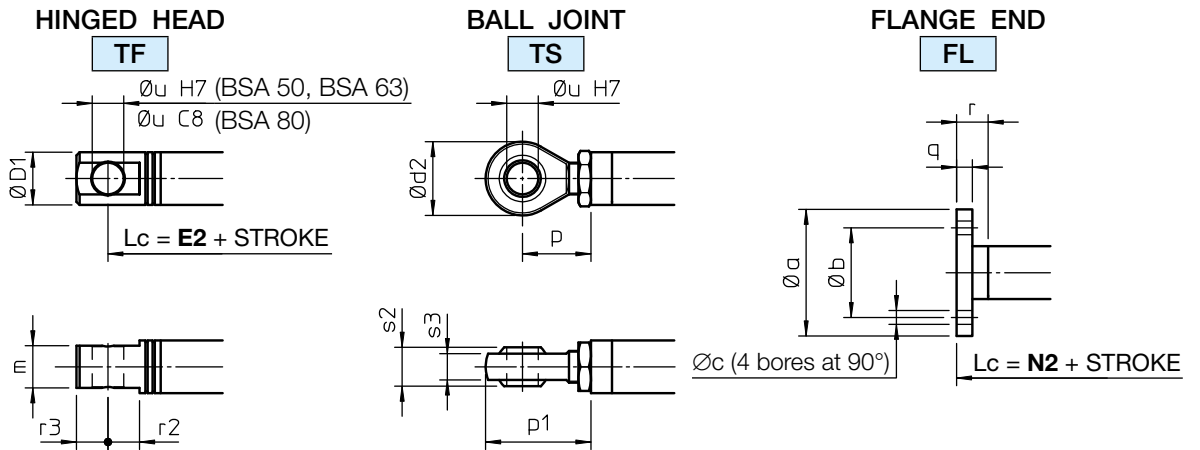

PROXIMITY STROKE LIMIT SWITCHES FCP Dimensions

	H	V	V1
BSA 50	79.5	263	70
BSA 63	86.5	314	71
BSA 80	99	371	10

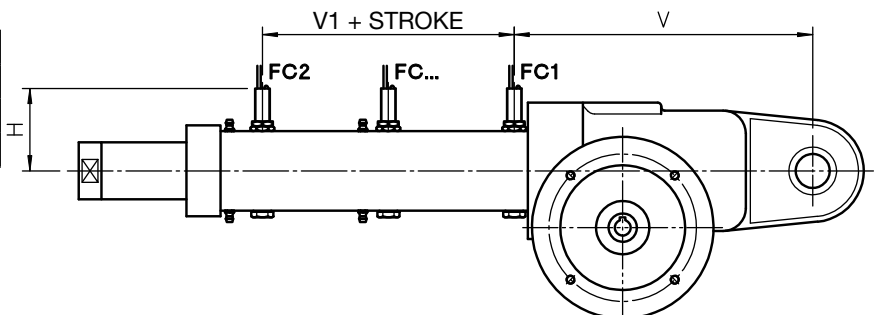

Linear actuators BSA Series

BALL SCREW LINEAR ACTUATORS BSA Series, size 50 – 63 – 80 AC 3-phase MOTOR – Proximity Stroke Limit Switches FCP STANDARD STROKE LENGTHS

	STROKE CODE	C100	C200	C300	C400	C500	C600	C700	C800	S2	T2	E2	N2
BSA 50										497	402	527	507
BSA 63	STROKE [mm]	100	200	300	400	500	600	700	800	579	471	609	589
BSA 80										673	576	708	693

NOTE: Different stroke lengths available on request. $L_a = L_c + \text{STROKE}$

For stroke lengths longer than 800 mm it is necessary to increase the guided length between push rod and outer tube to avoid axial backlash. Dimensions **S2**, **T2**, **E2** and **N2** shall be considered increased by 200 mm for stroke lengths up to 1500 mm.

For stroke lengths longer than 1500 mm, please, contact SERVOMECH.

	A	B	C	CH	∅ D1	∅ D2	∅ D3	F	G	H1	I	∅ P	R1
BSA 50	168	83	68	46	50	70	120	—	40	63	50	—	45
BSA 63	206	96	83	—	60	90	140	37	50	70	63	95	50
BSA 80	240	119	103	—	90	115	160	40	60	90	80	125	60

	a	b	c	e	∅ g	h	∅ i	l	∅ o	r1	s	t
BSA 50	140	105	185	143	30	100	M30×2	45	13	55	20	30
BSA 63	180	120	228	160	35	120	M36×2	55	17	58	30	30
BSA 80	210	122	278	180	40	130	M42×2	65	21	62	35	32

	Flange IEC	∅ Df	H2	J	Adapter IEC	∅ Dc	H3	J1
BSA 50	63 B5	140	120	102	80 B14 – 80 B5	120 – 200	110 – 150	176 – 182
	71 B5	160	130	102	90 B14 – 90 B5	140 – 200	120 – 150	182
BSA 63	80 B5	200	163	100	90 B14 – 90 B5	140 – 200	133 – 163	200
					100 B14 – 100 B5	160 – 250	143 – 188	220
BSA 80	80 B5; 90 B5	200	180	119	112 B14 – 112 B5	160 – 250	160 – 205	240

FRONT ATTACHMENT Dimensions

	∅ a	∅ b	∅ c	∅ D1	∅ d2	m	p
BSA 50	120	85	13	50	70	40	65
BSA 63	140	100	17	60	80	50	86
BSA 80	170	130	21	90	90	50	85

	p1	q	r	r2	r3	s2	s3	∅ u
BSA 50	100	15	30	30	30	37	25	30
BSA 63	126	15	30	30	35	43	28	35
BSA 80	130	20	40	35	45	49	33	40

PROXIMITY STROKE LIMIT SWITCHES FCP Technical features

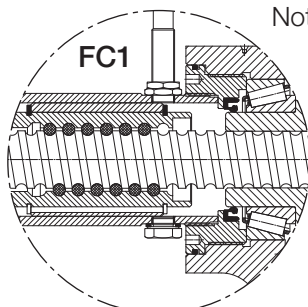

- Note: - The PROXIMITY SWITCH FC1, when activated, gives a signal to stop the motor by means of electric relays before the actuator reaches its minimal retracted length. The RETRACTED ACTUATOR LENGTH (L_c) and EXTENDED ACTUATOR LENGTH (L_a) of the actuator equipped with PROXIMITY SWITCHES FCP are longer than L_a and L_c of the actuator with electric stroke limit device FCE or without stroke end switches.
- Additional PROXIMITY SWITCHES are available for intermediate positions.
 - The minimum distance between the PROXIMITY SWITCHES must be of at least 25 mm.

Linear actuators BSA Series

BALL SCREW LINEAR ACTUATORS BSA Series, size 100 – 125
AC 3-phase MOTOR – with Electric Stroke End Switches FC

2

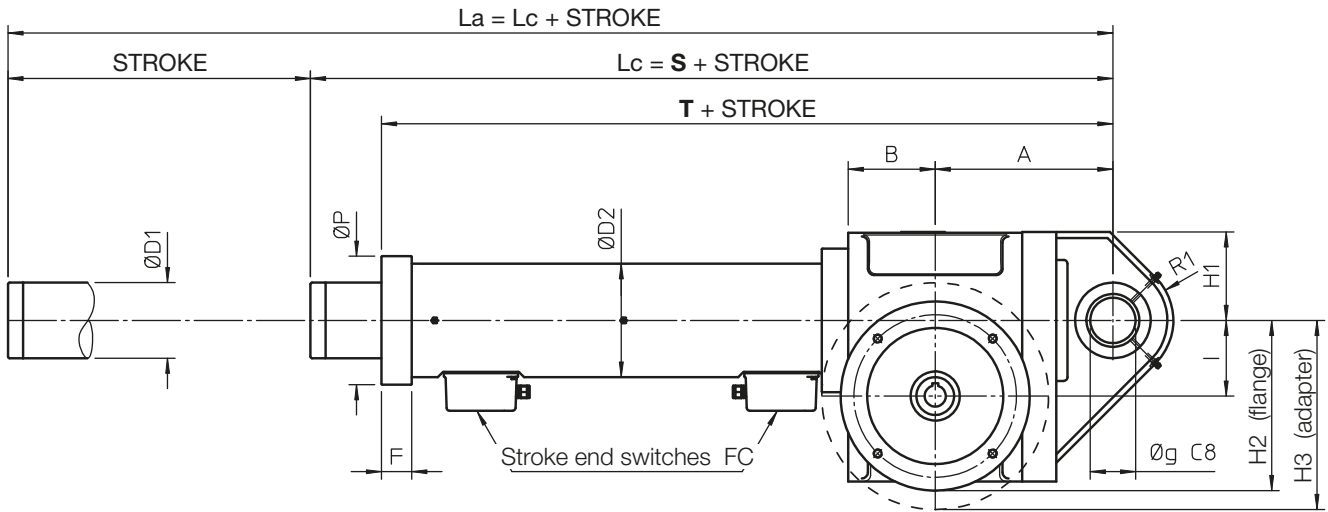

Lc - RETRACTED ACTUATOR length
 La - EXTENDED ACTUATOR length

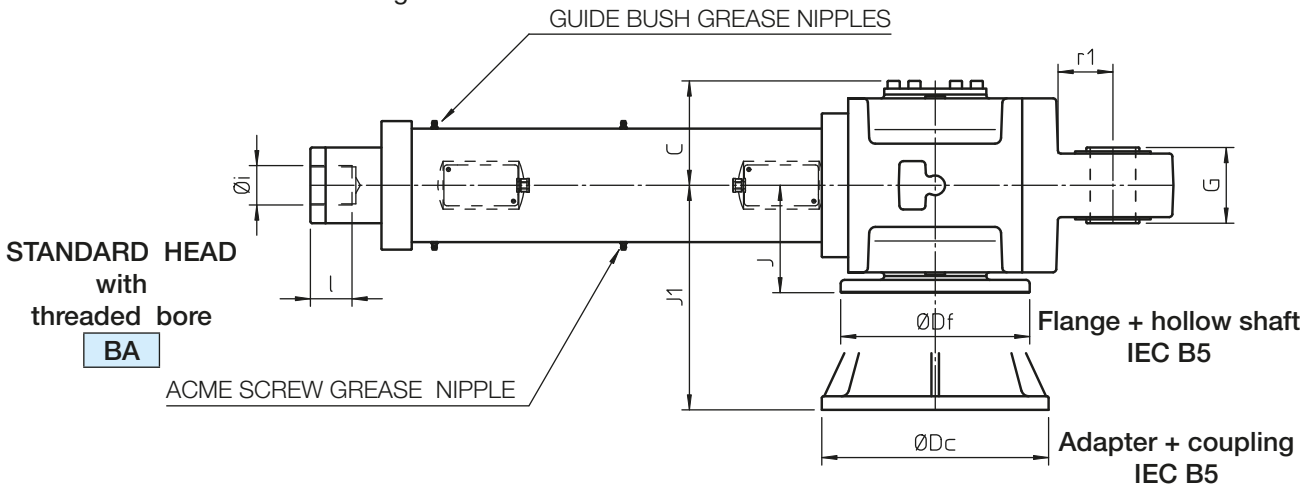

FRONT ATTACHMENTS

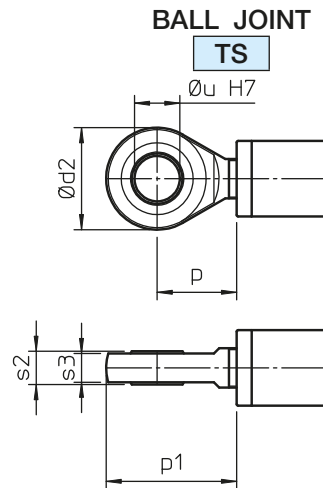
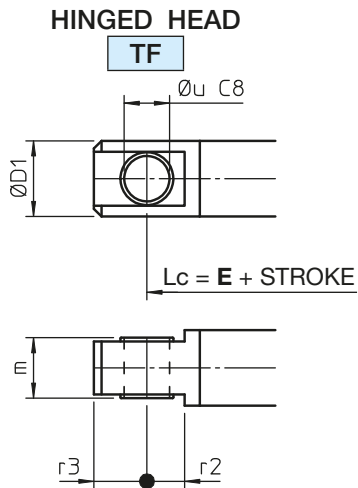

Linear actuators BSA Series

BALL SCREW LINEAR ACTUATORS BSA Series, size 100 – 125 AC 3-phase MOTOR – with Electric Stroke End Switches FC

	STROKE CODE	C...	S	T	E
BSA 100	STROKE [mm] = STROKE CODE	...	804	678	864
BSA 125			955	894	1040

NOTE: All stroke lengths are made on request.

For stroke lengths longer than 800 mm it is necessary to increase the guided length between push rod and outer tube to avoid axial backlash. Dimensions **S**, **T** and **E** shall be considered increased by 200 mm for stroke lengths up to 1500 mm.

For stroke lengths longer than 1500 mm please contact SERVOMECH.

	A	B	C	∅ D1	∅ D2	F	G	H1	I	∅ P	R1	∅ g	∅ i	l	r1
BSA 100	235	115	138	115	150	40	90	120	100	170	80	60	M60×4	60	72
BSA 125	320	140	173	160	200	—	100	335	125	—	90	80	M80×4	80	100

	Flange IEC	∅ Df	H2	J	Adapter IEC	∅ Dc	H3	J1
BSA 100	90 B5	200	225	142	132 B5	300	250	297
	100-112 B5	250	250	142				
BSA 125	—	—	—	—	132 B5	300	275	353
					160 B5	420	335	365

FRONT ATTACHMENT Dimensions

	∅ D1	∅ d2	m	p	p1	r2	r3	s2	s3	∅ u
BSA 100	115	135	70	95	163	50	70	44	38	60
BSA 125	150	180	100	130	220	80	80	55	47	80

Linear actuators ATL Series and BSA Series

2.5 OPTIONS AND ACCESSORIES

MOTOR MOUNTING SIDE – MAIN INPUT SIDE



ON REQUEST: LEFT side
Code: LH

STANDARD: RIGHT side
Code: RH

ELECTRIC MOTOR TERMINAL BOX POSITION

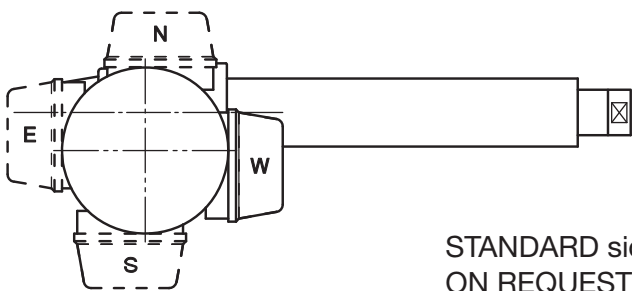

STANDARD side: W
ON REQUEST side: E ; N ; S

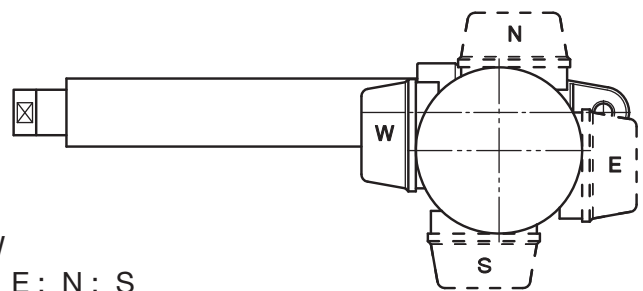

POSITION OF FRONT AND REAR ACTUATOR ATTACHMENT



STANDARD



ON REQUEST: turned at 90°
Code: RPT 90°
NOTE: NOT available for size 100 and 125

INTERMEDIATE FLANGE Code FI

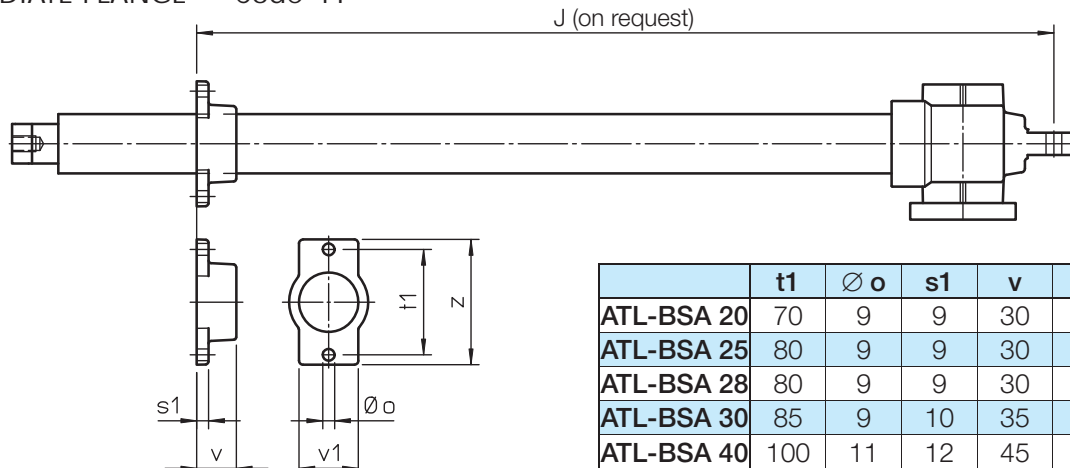

	t1	Ø o	s1	v	v1	z
ATL-BSA 20	70	9	9	30	40	85
ATL-BSA 25	80	9	9	30	45	95
ATL-BSA 28	80	9	9	30	45	95
ATL-BSA 30	85	9	10	35	50	100
ATL-BSA 40	100	11	12	45	60	120

NOTE: the intermediate flange FI can be used as sustainer only and not to support the axial load!

Linear actuators ATL Series and BSA Series

2.5 OPTIONS

ACTUATOR INPUT – size 20 - 25 - 28 - 30 - 40

Single input shaft

Code: **Vers.1**

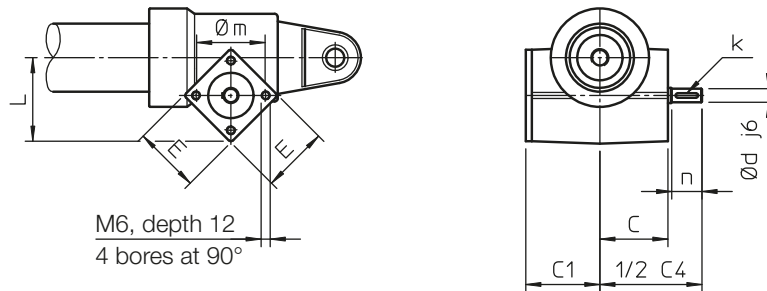

Double input shaft

Code: **Vers.2**

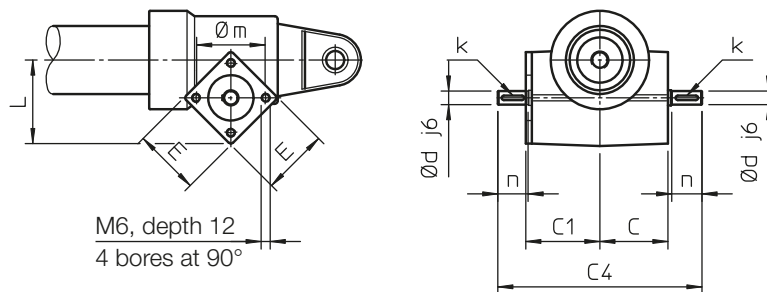

Attachment for IEC _ B14 electric motor (flange and hollow shaft)

Code: **Vers.3**

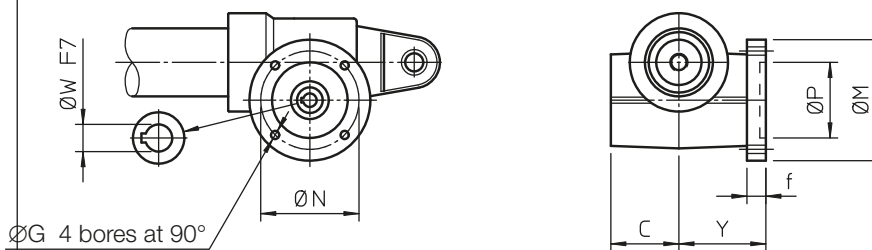

Attachment for IEC _ B14 electric motor (flange and hollow shaft) and second shaft

Code: **Vers.4**

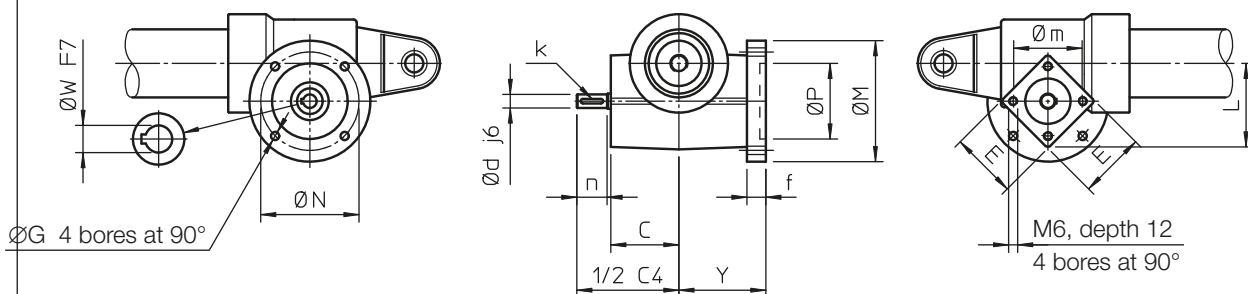

Attachment for IEC motor: flange and hollow shaft

	C	C1	C4	E	L	k	Y	Ø d	Ø m	n	IEC motor	Ø G	Ø M	Ø N	Ø P	Ø W	f
ATL-BSA 20	45	49	135	44	58	3×3×15	58	9	46	20	56 B14	5.5	80	65	50	9	12.5
ATL-BSA 25	45	49	135	44	58	3×3×15	58	9	46	20	56 B14	5.5	80	65	50	9	12.5
ATL-BSA 28	45	—	135	44	58	3×3×15	58	9	46	20	63 B14	5.5	90	75	60	11	12
ATL-BSA 30	50	54	149	52	66	3×3×15	62	10	54	22	63 B14	5.5	90	75	60	11	12
ATL-BSA 40	57	61	179	53	80	5×5×20	69	14	54	30	71 B14	6.5	105	85	70	14	12

Linear actuators ATL Series and BSA Series

2.5 OPTIONS

ACTUATOR INPUT – size 50 - 63 - 80

2

Single input shaft

Code: **Vers.1**

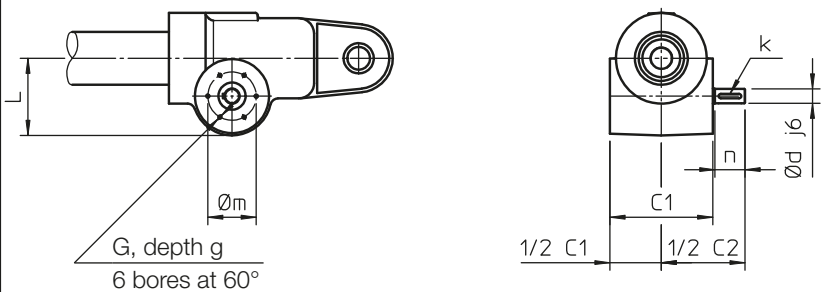

Double input shaft

Code: **Vers.2**

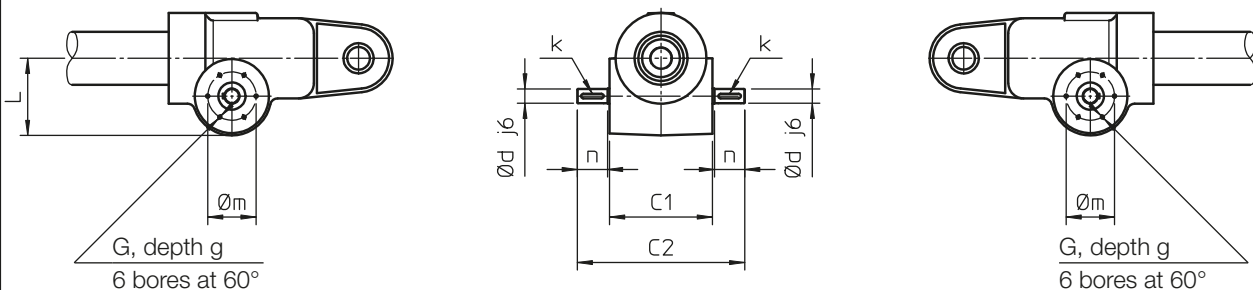

Attachment for IEC _ B5 electric motor (flange and hollow shaft)

Code: **Vers.3**

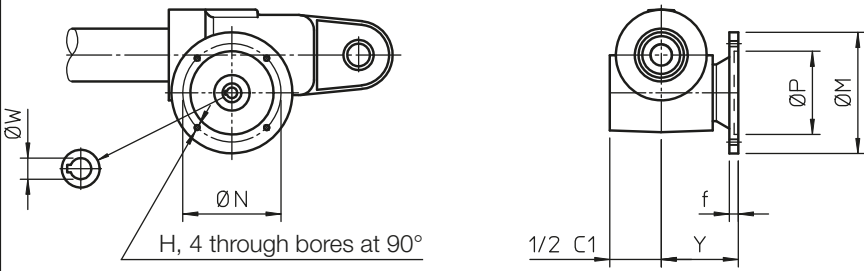

Attachment for IEC _ B5 electric motor (flange and hollow shaft) and second shaft

Code: **Vers.4**

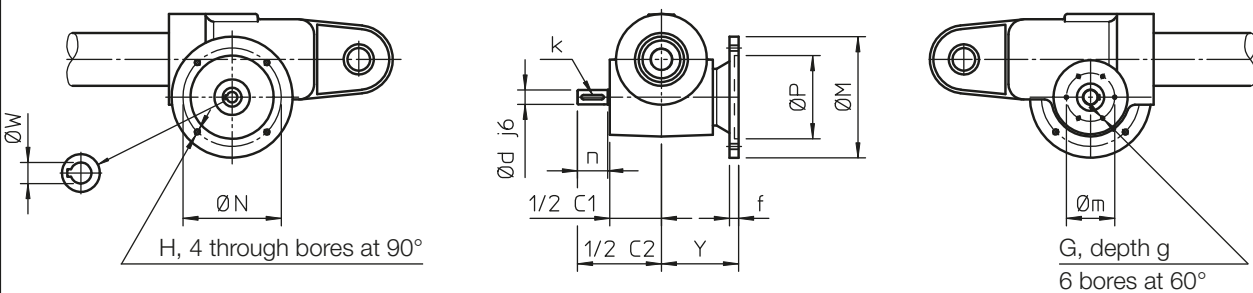

Linear actuators ATL Series and BSA Series

2.5 OPTIONS

ACTUATOR INPUT – size 50 - 63 - 80

Attachment for IEC _ B5 or IEC _ B14 electric motor (adapter and coupling)

Code: **Vers.5**

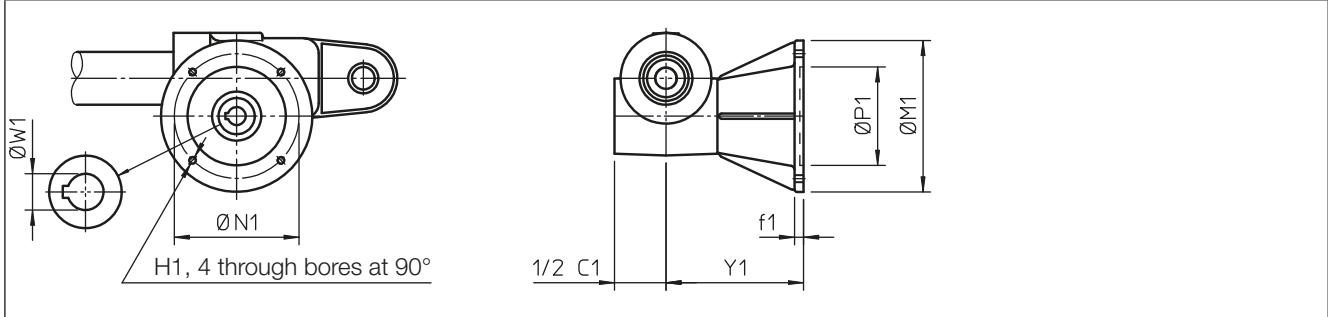

Attachment for IEC _ B5 or IEC _ B14 electric motor (adapter and coupling) and second shaft

Code: **Vers.6**

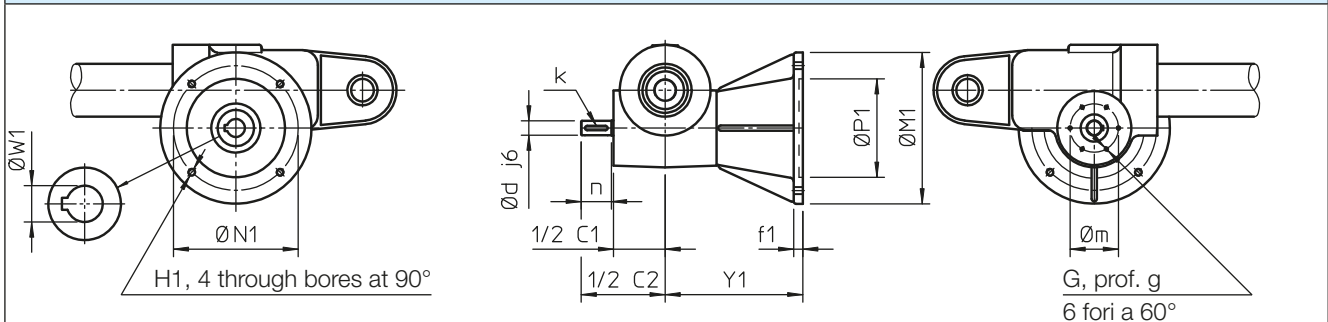

	C1	C2	G	L	g	Ø d	k	Ø m	n
ATL-BSA 50	136	222	M5	102	10	19	6x6x30	64	40
ATL-BSA 63	165	269	M6	125	14	24	8x7x40	63	50
ATL-BSA 80	205	330	M6	143	14	28	8x7x40	74	60

Attachment for IEC electric motor: flange and hollow shaft

	IEC motor		H	Ø M		Ø N		Ø P		Ø W		Y	f
ATL-BSA 50	63 B5	71 B5	M8	140	160	115	130	95	110	11	14	102	12
ATL-BSA 63	80 B5		M10	200		165		130		19		100	12
ATL-BSA 80	80 B5	90 B5	M10	200		165		130		19		119	12

Attachment for IEC electric motor: adapter and coupling

	IEC motor		H1		Ø M1		Ø N1		Ø P1		Ø W1		Y1	f1
ATL-BSA 50	80 B14	80 B5	Ø 6.5	M10	120	200	100	165	80	130	19	182	10	12
ATL-BSA 63	90 B14	90 B5	Ø 8.5	M10	140	200	115	165	95	130	24	220	10	12
ATL-BSA 80	100 B14	100 B5	Ø 8.5	M12	160	250	130	215	110	180	28	240	15	17

Attachment for IEC electric motor: adapter and coupling

	IEC motor		H1		Ø M1		Ø N1		Ø P1		Ø W1		Y1	f1
ATL-BSA 50	90 B14	90 B5	Ø 8.5	M10	140	200	115	165	95	130	24	182	10	12
ATL-BSA 63	100-112 B14	100-112 B5	Ø 8.5	M12	160	250	130	215	110	180	28	220	15	17
ATL-BSA 80	112 B14	112 B5	Ø 8.5	M12	160	250	130	215	110	180	28	240	15	17

Linear actuators ATL Series and BSA Series

2.5 OPTIONS

ACTUATOR INPUT – size 100 - 125

Single input shaft

Code: **Vers.1**

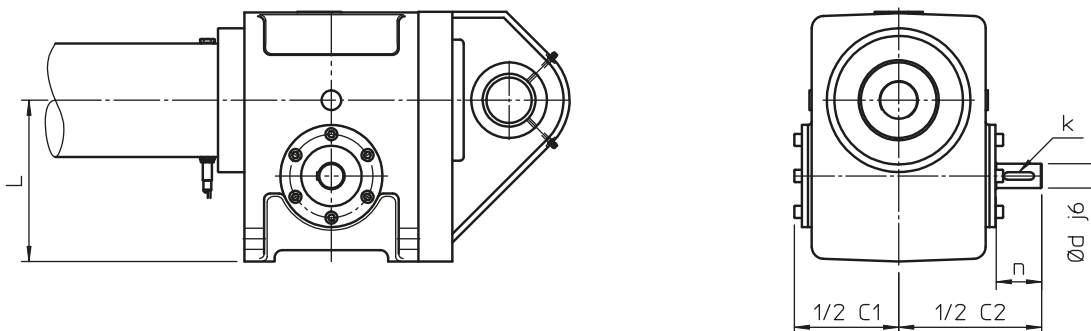

Double input shaft

Code: **Vers.2**

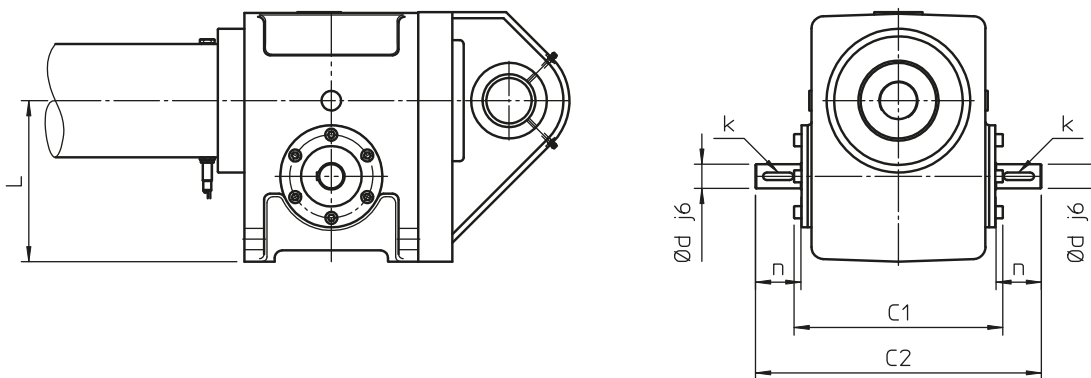

Attachment for IEC _ B5 electric motor (flange and hollow shaft)

Code: **Vers.3**

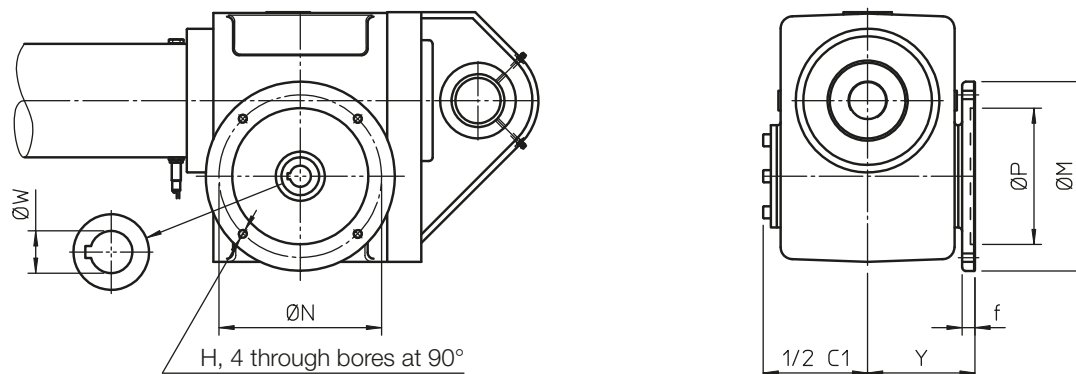

Attachment for IEC _ B5 electric motor (flange and hollow shaft) and second shaft

Code: **Vers.4**

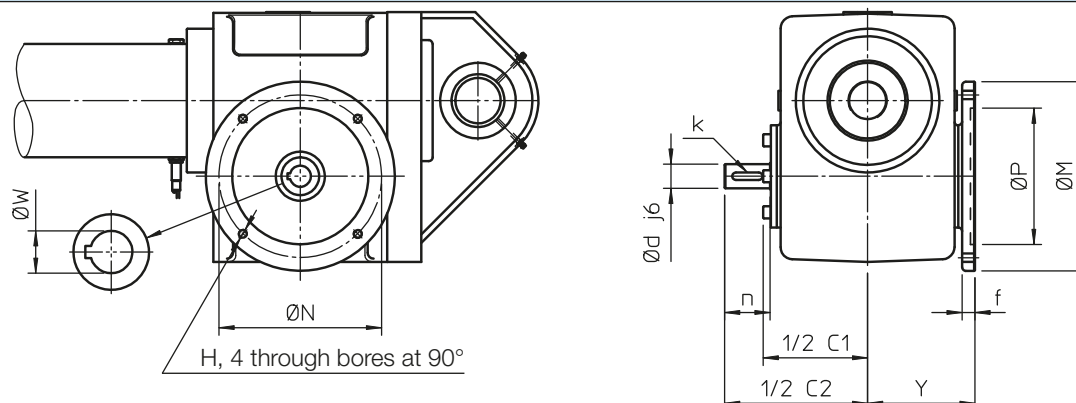

Linear actuators ATL Series and BSA Series

2.5 OPTIONS

ACTUATOR INPUT – size 100 - 125

2

Attachment for IEC _ B5 electric motor (adapter and coupling)
Code: **Vers.5**

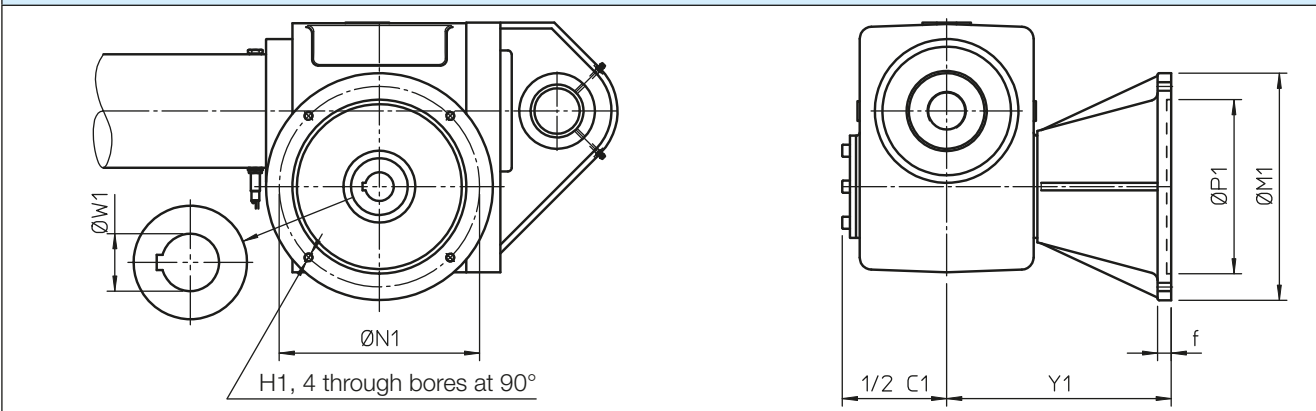

Attachment for IEC _ B5 electric motor (adapter and coupling) and second shaft
Code: **Vers.6**

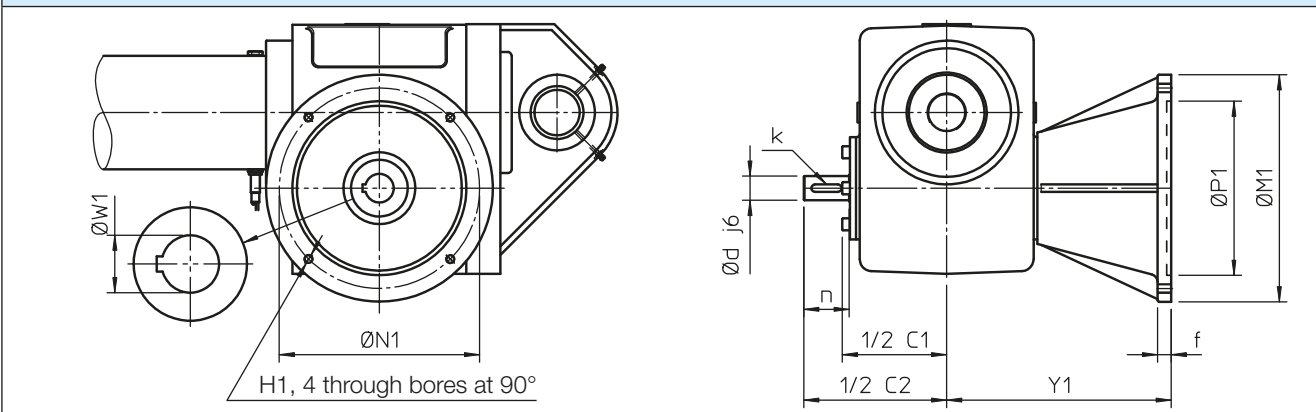

	C1	C2	L	Ø d	k	n
ATL-BSA 100	276	378	225	32	10×8×40	60
ATL-BSA 125	346	490	260	38	10×8×60	80

Attachment for IEC electric motor: flange and hollow shaft

	IEC motor	H	Ø M	Ø N	Ø P	Ø W	Y	f
ATL-BSA 100	90 B5	M10	200	165	130	24	142	17
	100-112 B5	M12	250	215	180	28	142	17

Attachment for IEC electric motor: adapter and coupling

	IEC motor	H1	Ø M1	Ø N1	Ø P1	Ø W1	Y1	f1
ATL-BSA 100	132 B5	M12	300	265	230	38	297	18
ATL-BSA 125	132 B5	M12	300	265	230	38	508	16
	160 B5	M16	350	300	250	42	520	22

Linear actuators ATL Series and BSA Series

2.5 ACCESSORIES

ELECTRIC STROKE LENGTH LIMIT DEVICE Code FCE

The ELECTRIC STROKE LENGTH LIMIT DEVICE allows to limit the actuator stroke length avoiding to reach the extreme positions (mechanical stop) and preventing damage. It is a strong and reliable device, suitable for indoor and outdoor environments; it is available for all standard stroke lengths and for special stroke lengths on request.

The FCE device consists of 2 normally closed electric switches installed inside a sealed box made in engineering plastic or aluminium alloy. A brass collar allows, with its special shape, activation of the electric switches. It is balanced by 2 opposite preloaded helical springs, which reset the position when the actuator starts moving again in the opposite direction. 2 wiper seals between the axial travelling collar and the housing. The activation of the collar, and consequently of the limit switches, in one or in the opposite direction is done by a stainless steel rod driven by the push rod. The stainless steel rod slides inside the collar activating it when the adjustable ring **1** or **2** pushes on the collar, which activates the switches **FC 1** and **FC 2**.

The stop position is easy to adjust: ring **1** fixes the RETRACTED ACTUATOR (Lc) stop position, ring **2** fixes the EXTENDED ACTUATOR (La) stop position. The adjustment of both rings **1** and **2** is made directly on the actuator cylinder, so it is very easy to set the actuator stop positions.

The total actuator stroke length can be set by adjusting both rings **1** and **2** in the required extreme positions. The safety extra-stroke cannot be used! If the application requires an extra-stroke to stop the actuator, please, contact SERVOMECH.

WARNING: Compare the stroke length required by the application to the actuator dimensions (refer to the CHECK SHEET supplied with the actuator). The FCE device controls only the actuator stroke length, so the stroke length required by the application must fit within it and cannot be longer!

The ELECTRIC STROKE LENGTH LIMIT DEVICE must be connected to the electric control circuit as shown in the following WIRING DIAGRAM, to guarantee motor switch off and to prevent damage to the actuator and the machine.

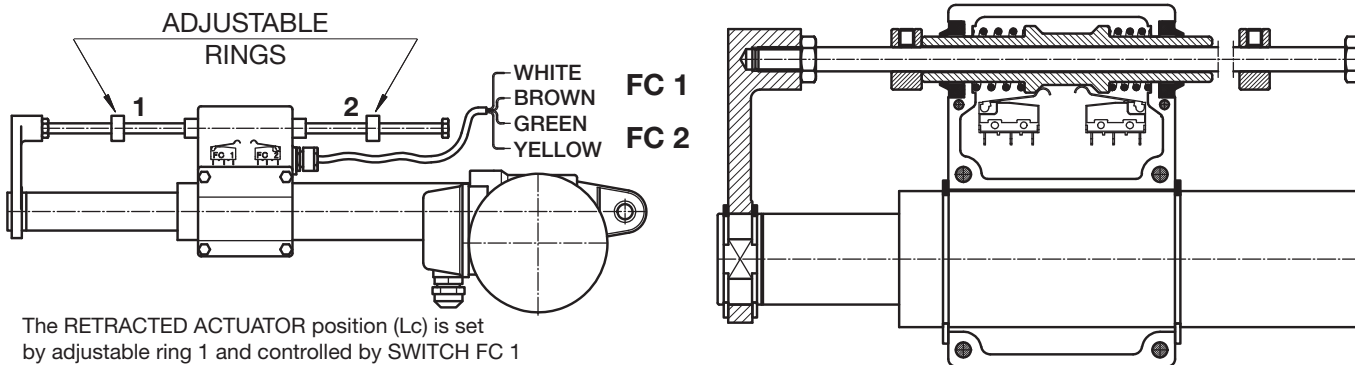

The RETRACTED ACTUATOR position (Lc) is set by adjustable ring 1 and controlled by SWITCH FC 1
 The EXTENDED ACTUATOR position (La) is set by adjustable ring 2 and controlled by SWITCH FC 2

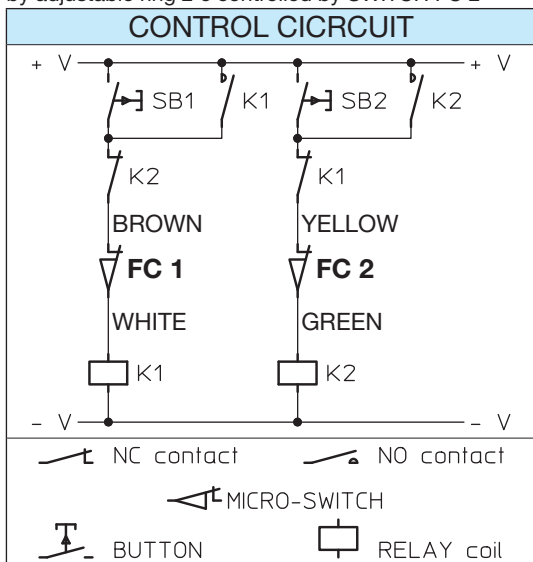

The FCE device is recommended for linear speeds up to about 30 mm/sec. For higher speeds it is better to use magnetic or proximity switches because, due to the inertia, the actuator could travel over the safe stop position and damage the front lever. The stop can be ensured by a brake motor.

RATED CONTACT VALUES			
Voltage	250 V AC	30 V DC	125 V DC
Current (resistive load)	5 A	5 A	1.4 A
Current (inductive load)	3 A	0.1 A	—

The FCE device is equipped with a multicore cable 4 × 0.75 mm², standard length 1.5 m; longer cable on request.

Electric micro-switches with max. current (referred to resistive load) of 10 A are available on request.

Linear actuators ATL Series and BSA Series

2.5 ACCESSORIES

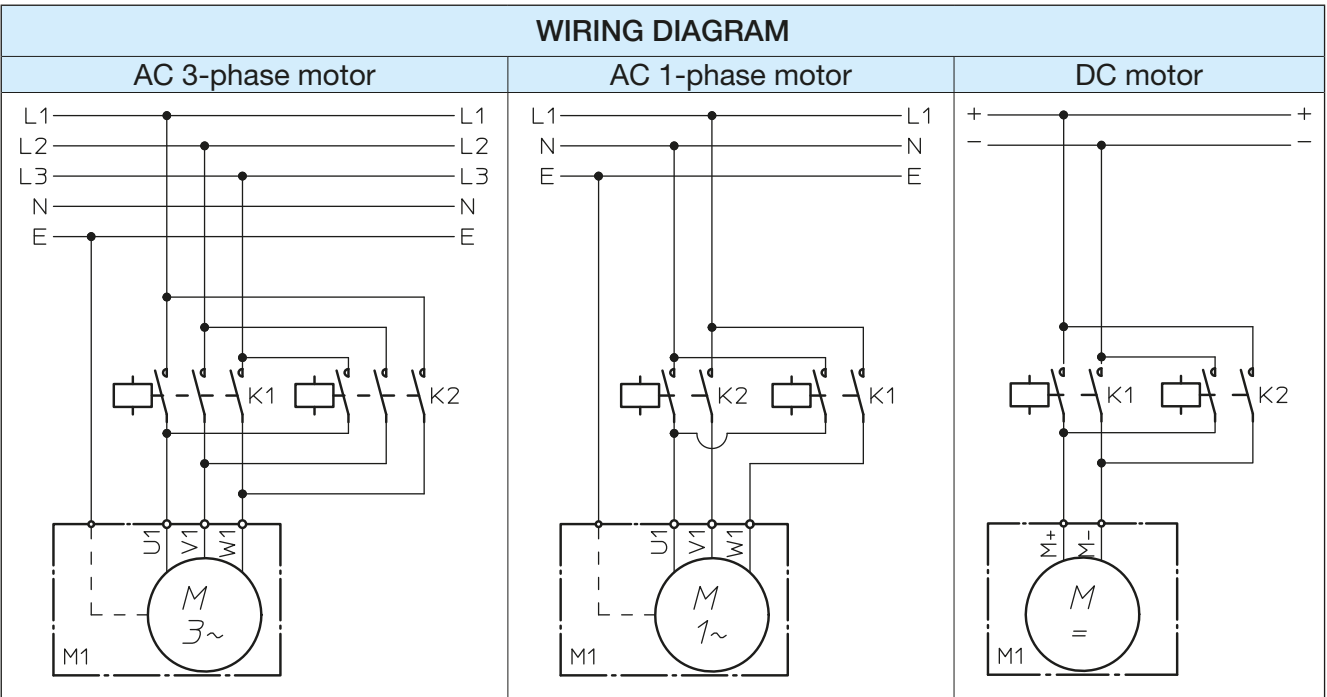

ELECTRIC STROKE END SWITCHES Code FC

The ELECTRIC STROKE END SWITCHES FC allow to limit the actuator stroke avoiding to reach the extreme positions (mechanical stops) and preventing damage. The device consists of two switch assemblies, each of them consisting of one miniature electric switch (FC 1, FC 2) fixed to the relative support, a switch operating cam, rotating around the relative support pin when operated by the actuator nut, and a spring that allows the return of the cam to its neutral position, thus deactivating the switch; the entire assembly is covered by an aluminium cover and sealed by a rubber seal. Each assembly determines one of the two extreme positions of the push rod (Lc or La), but it can not be used to fix any intermediate position. The position of the assembly along the push rod is not adjustable.

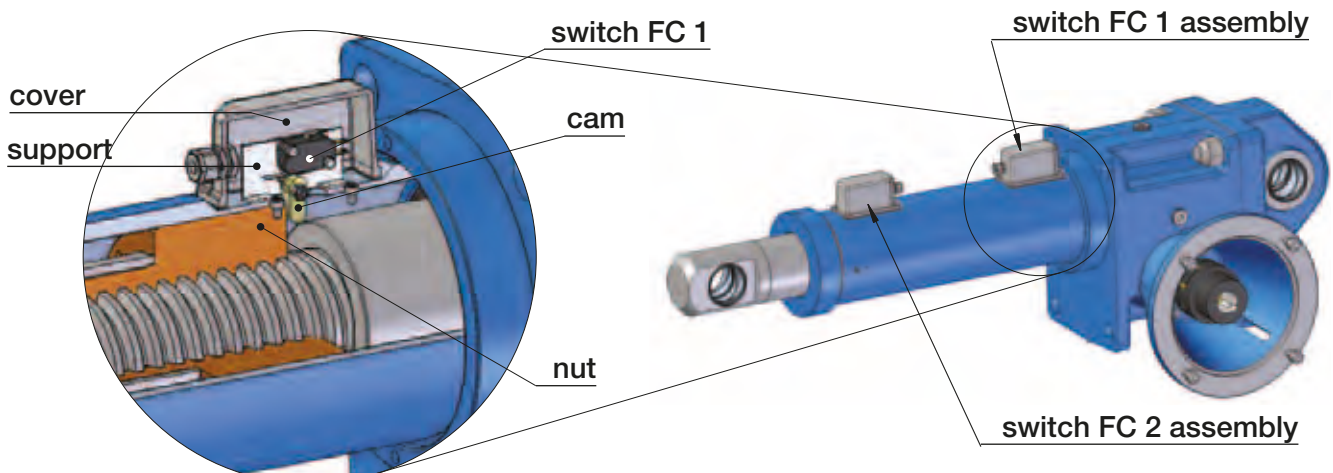

The ELECTRIC STROKE END SWITCHES FC must be connected to the electric control circuit to guarantee the motor switch off and to prevent damages to the actuator and the application equipment. The relevant WIRING DIAGRAM is on page 88.

RATED CONTACT VALUES			
Voltage	250 V AC	125 V AC	125 V DC
Current (resistive load)	16 A	16 A	0.6 A
Current (inductive load)	10 A	10 A	0.6 A

The ELECTRIC STROKE END SWITCHES FC are available for actuators of both ATL and BSA Series for size 100 and 125.

2.5 ACCESSORIES

MAGNETIC STROKE END SWITCHES Code FCM

The MAGNETIC STROKE END SWITCHES FCM allow to limit the actuator stroke length avoiding to reach the extreme positions (mechanical stop) and preventing damage. Using more switches it is also possible to set intermediate positions along the actuator stroke length.

These reeds can be used to stop the actuator or simply to signal its position during the linear motion.

A magnetic ring on the actuator push road creates a toroidal magnetic field of 100 Gauß.

The stroke end switches must be fixed on the push rod and are activated by the toroidal magnetic field independently of their angular position.

The outer tubes are made in non-magnetic material, such as anodized aluminium or stainless steel, thus allowing the external transmission of the magnetic field and therefore activation of the reeds switches.

The standard construction of actuators with FCM includes the outer tube in anodized aluminium; tubes in stainless steel are available on request.

The stroke end switches must be fixed with clamps in non-magnetic material and, to be activated, they must be mounted with the side with the code number upwards (the sensor code number shall be visible).

WARNING: Max. performances stated in this catalogue and/or technical data sheets supplied with the actuator must not be exceeded, in order to avoid damages and malfunction!
The magnetic reed switches can work only if connected to a control circuit to activate electric relay. They shall not be connected in series between the power supply and the electric motor.

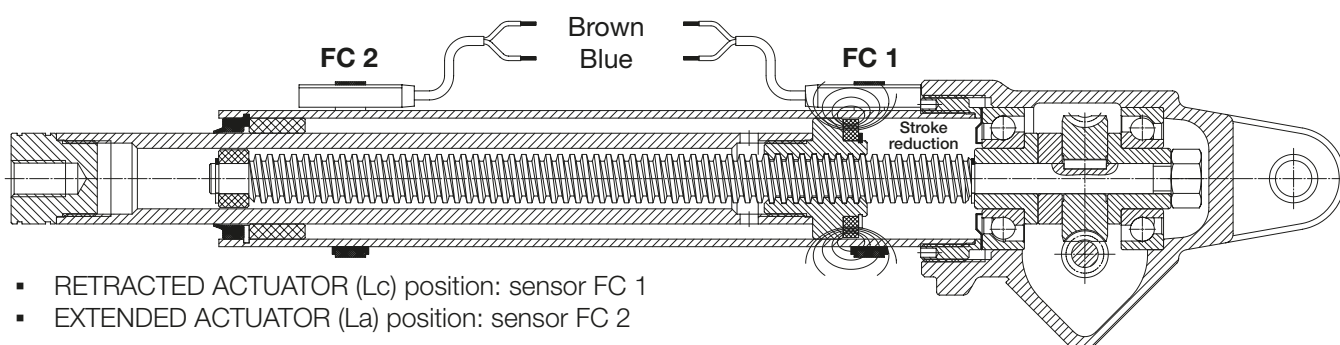

- RETRACTED ACTUATOR (Lc) position: sensor FC 1
- EXTENDED ACTUATOR (La) position: sensor FC 2

Actuators equipped with MAGNETIC STROKE END SWITCHES perform a linear travel shorter than their stroke length code, because the reed switch FCM 1 gives the stopping signal to the actuator before the actuator has travelled the total stroke length. To know the difference refer to the tables relating to the STROKE LENGTHS AVAILABLE IN STOCK WITH FCM on the pages concerning the OVERALL DIMENSIONS.

The toroidal magnetic field created by the internal magnetic ring has an arch-like form. When using more contact reeds for intermediate positions, it shall be considered that the same reed switch can give the signal in 2 different positions, depending on the actuator motion which can be retracting or extending. To know the difference between these 2 positions please contact SERVOMECH.

The position of the reed switches can be adjusted by changing the fixing clamp position on the outer tube.

The extreme reed switches positions are:

- RETRACTED ACTUATOR (Lc) position: the reed switch fixed on the tube up to the actuator housing
- EXTENDED ACTUATOR (La) position: the reed switch must exceed the limit marked on the outer tube. This limit position is stated on the tables stating the dimensions for standard stroke lengths up to 800 mm.

For special stroke lengths longer than 800 mm, the limit position is the one marked on the tube, otherwise please contact SERVOMECH (also in this case it is marked on the actuator).

NOTE: The FCM is not available if the actuator is equipped with ANTI-TURN device AR.

The MAGNETIC STROKE END SWITCHES FCM are available for actuators of both ATL and BSA Series, for size 20 ... 40.

Linear actuators ATL Series and BSA Series

2.5 ACCESSORIES

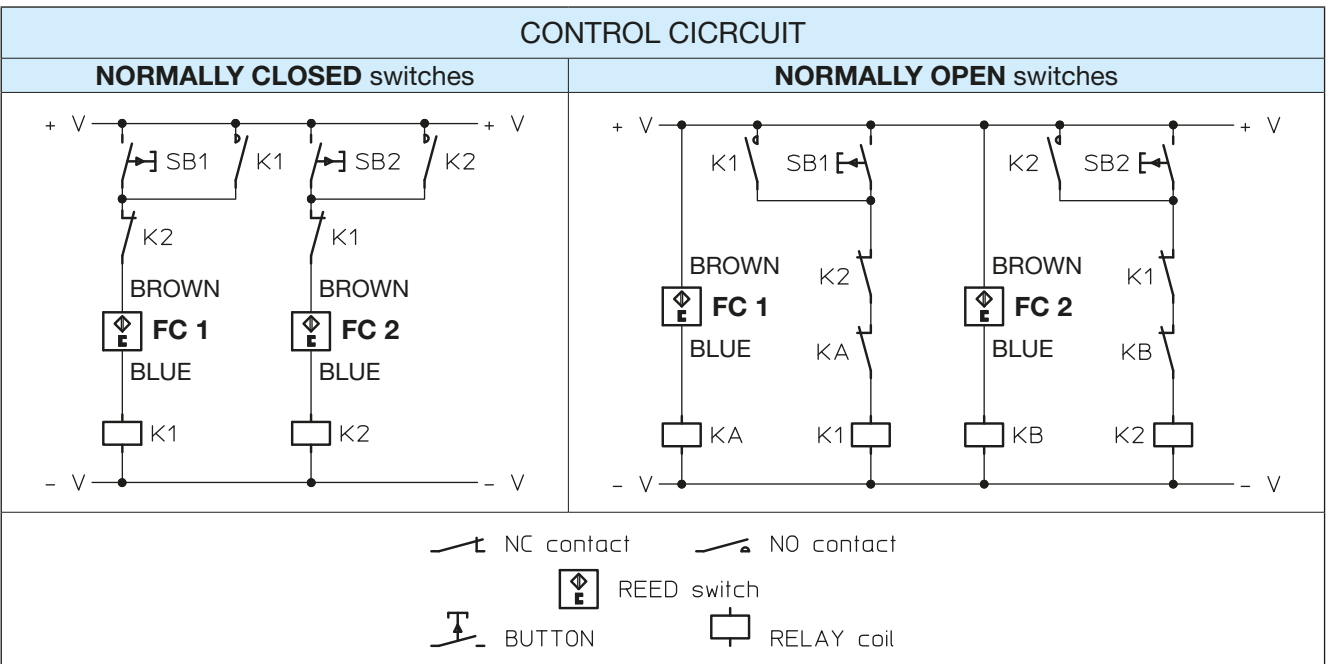

ELECTRIC FEATURES		
Voltage	(3 ... 130) V DC	(3 ... 130) V AC
Max. commutable power	20 W	20 VA
Max. commutable current	300 mA (resistive load)	
Max. inductive load	3 W (simple coil)	

The reed switches are equipped with a multicore cable $2 \times 0.25 \text{ mm}^2$, standard length 2 m.

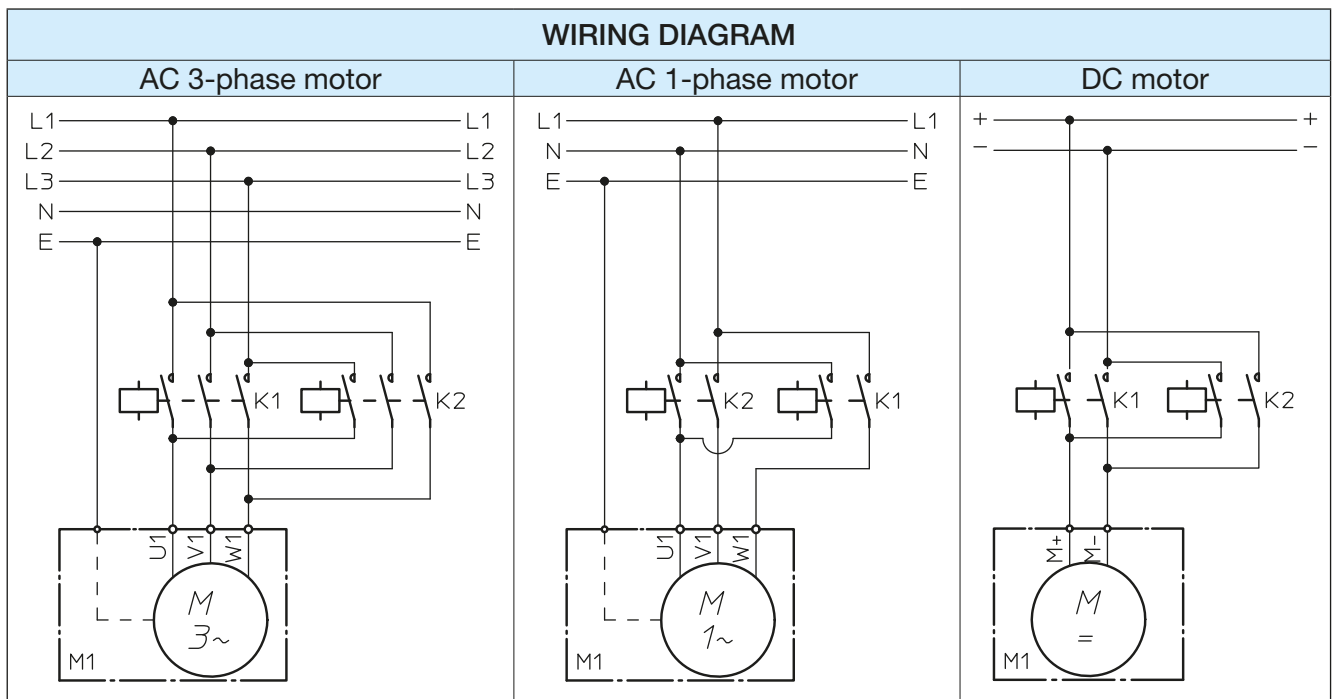

Linear actuators ATL Series and BSA Series

2.5 ACCESSORIES

INDUCTIVE PROXIMITY STROKE END SWITCHES Code FCP

The INDUCTIVE PROXIMITY STROKE END SWITCHES FCP allow the actuator to stop before reaching the internal mechanical stop avoiding damage. They can be also used to fix intermediate positions along the actuator stroke length.

The INDUCTIVE PROXIMITY STROKE END SWITCHES are fixed directly on the actuator outer tube in the required position. Their position is not adjustable. Standard proximity switches are normally closed.

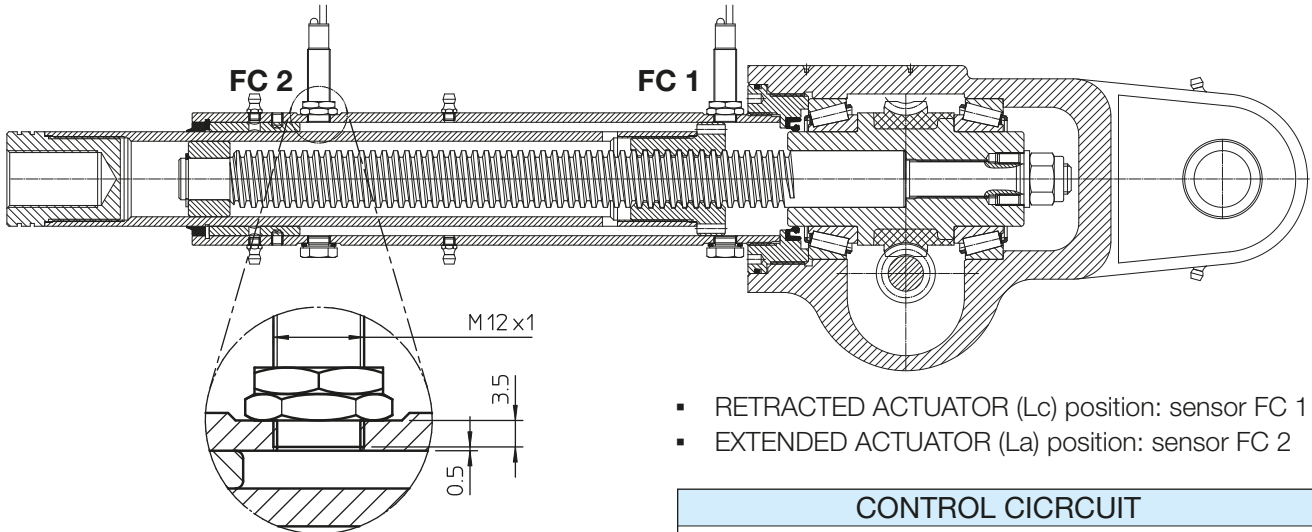

- RETRACTED ACTUATOR (Lc) position: sensor FC 1
- EXTENDED ACTUATOR (La) position: sensor FC 2

ELECTRIC FEATURES	
Voltage	(10 ... 30) V DC
Max. output current	200 mA
Voltage drop (activated switch)	< 3 V (at 200 mA)

The switches are equipped with a multicore cable $3 \times 0.2 \text{ mm}^2$, standard length 2 m.

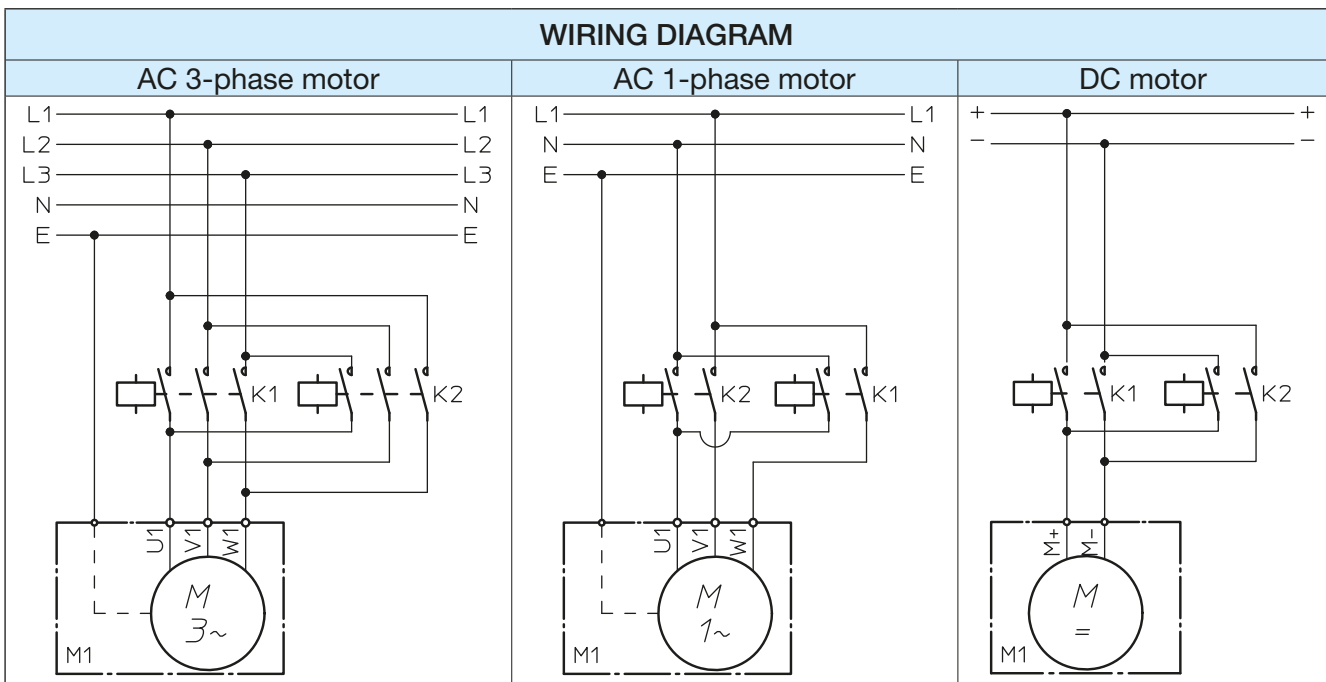
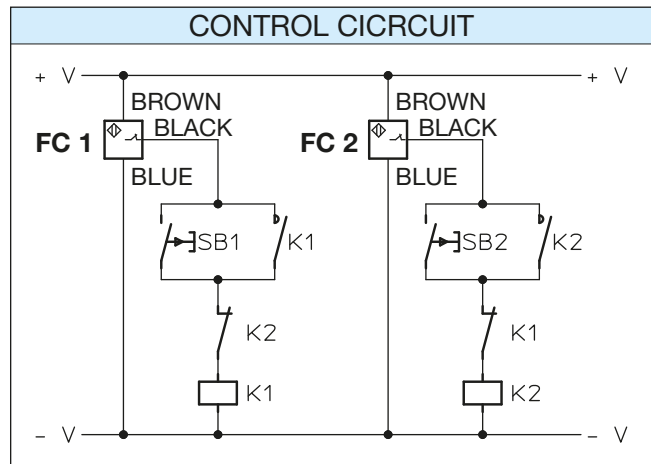
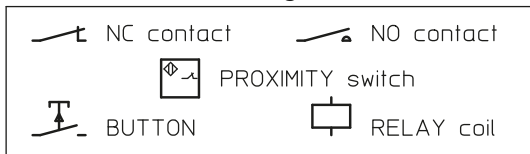

Linear actuators ATL Series and BSA Series

2.5 ACCESSORIES

2

ANTI-TURN device Code AR

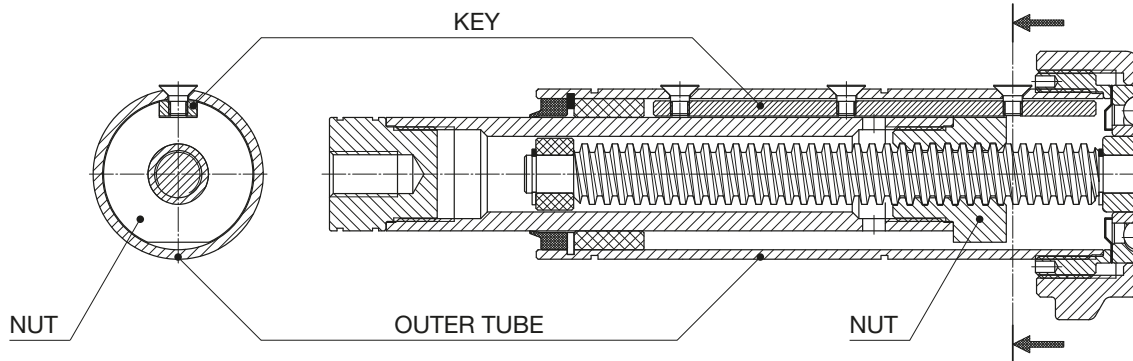

To achieve a linear motion it is necessary to prevent the rotary movement of the nut and of the push rod fixed to it. In many applications it is the external structure itself that, being connected to the push rod, prevents the rotation and allows the linear motion.

In some cases the load applied on the push rod cannot be guided and therefore the rotation cannot be avoided. In such cases it is necessary to use actuators with an internal anti-turn device. The ANTI-TURN device allows the linear motion without any external reaction on the push rod. It can be supplied upon request.

The anti-turn device shown in the above picture consists in a steel key fixed and aligned along the outer tube. The bronze nut, provided with a suitable keyway, slides on this key, making translate the push rod.

The ANTI-TURN device AR is available for linear actuators ATL 25, ATL 28, ATL 30, ATL 40, ATL 50, ATL 63 and ATL 80. **It is not available** for actuators ATL 20, for all acme screw linear actuators (ATL Series) equipped with MAGNETIC STROKE END SWITCHES FCM and for all ball screw linear actuators (UBA Series).

SAFETY CLUTCH Code FS

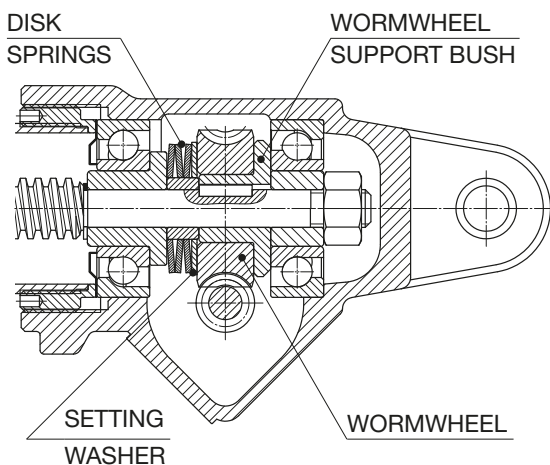

The SAFETY CLUTCH is a device able to protect the actuator and the machinery where it is installed from dynamic overload during the linear travel and from incorrect use which could bring the actuator to the mechanical stop. This device is a torque limiter on the worm wheel. The torque limiter clutch is preloaded during assembly. The preload is fixed and related to the ratio and the performances of each actuator as stated on the PERFORMANCE TABLES in this catalogue.

On request, with a purchasing order, a different preload can be set to achieve different performance.

If an overload is applied on the actuator, the SAFETY CLUTCH starts slipping and the push rod stops while the motor is still running.

When the overload decreases up to the rated load value or less, the SAFETY CLUTCH stops slipping and the push rod starts travelling again. The SAFETY CLUTCH FS is not intended to be used as a load limiter, but only to protect the actuator and the machinery where it is installed. Do not use the SAFETY CLUTCH as a stroke end control device! If it is frequently activated it rapidly wears, the preload is reduced and consequently also the actuator load performance is lower.

The SAFETY CLUTCH FS can be supplied for actuators of both ATL and BSA Series for sizes 20 – 25 - 28 -30 and 40.

Linear actuators ATL Series and BSA Series

2.5 ACCESSORIES

SAFETY NUT Code MS

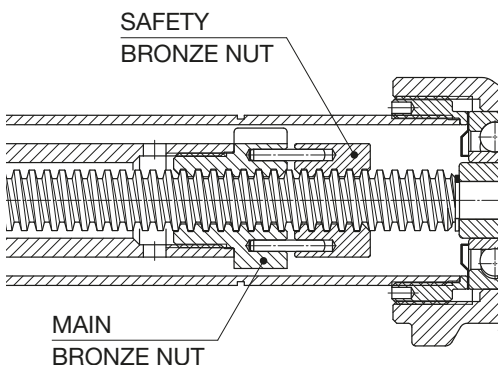

The SAFETY NUT is an auxiliary bronze nut connected by 2 pins to the main bronze nut. The distance between the two nuts in a new actuator is equal to a half of the thread pitch. If the main nut wears up to a half of the thread pitch or crashes, the SAFETY NUT supports the load avoiding its fall.

The SAFETY NUT is a one-direction device. Its position with respect to the main nut depends on the load direction. The SAFETY NUT is available for actuators working with push load. For applications with pull load a special design is available (contact SERVOMECH).

The SAFETY NUT MS is available for all acme screw actuators (ATL Series) except for actuator ATL 20 equipped with FCM device.

PROTECTIVE BELLOWS Code B

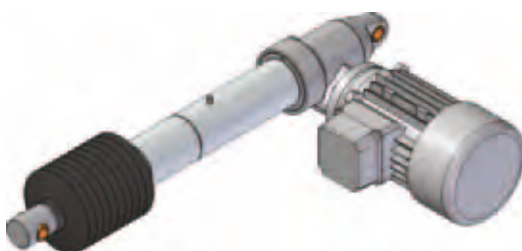

When the actuators are used in severe environment conditions with contaminant agents that can damage the seal scraper between the outer tube and the push rod, BELLOWS protection can be useful.

Bellows made of special materials for severe environments are available upon request.

LINEAR TRANSDUCER

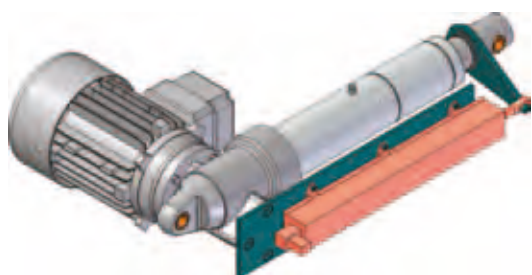

On request, all linear actuators of both ATL and BSA Series can be supplied with an external absolute linear transducer such as linear potentiometer or linear encoder. For further information, please, contact SERVOMECH.

ROTARY ENCODER

For the positioning control of all linear actuators ATL Series and BSA Series (all sizes), an incremental rotary encoders can be supplied fixed on the input shaft on the side opposite to the motor.

On request, the linear actuator can be equipped with an absolute rotary encoder.

In case of linear actuators with DC motor, the motor can be supplied with a tacho-generator mounted on the opposite side of the motor shaft.

Linear actuators ATL Series and BSA Series

2.5 ACCESSORIES

ROTARY ENCODER Code ENC.4

Hall-effect encoder, incremental, bi-directional
 Resolution: 4 pulses per revolution
 Output: PUSH-PULL
 2 channels (A and B, phase difference 90°)
 Input voltage: (8 ... 32) Vdc
 Max. commutable current (I_{out}): 100 mA
 Max output voltage drop:
 with load connected to 0 and $I_{out} = 100$ mA: 4.6 V
 with load connected to + V and $I_{out} = 100$ mA: 2 V
 Protection:
 against short circuit
 against input polarity inversion
 against any incorrect output connection
 Cable length: 1.3 m
 Protection: IP 55

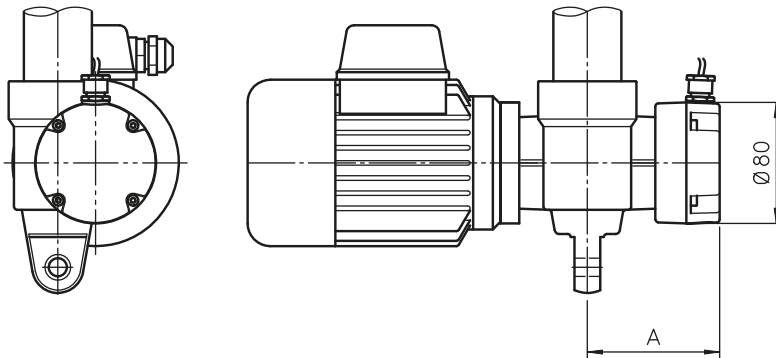
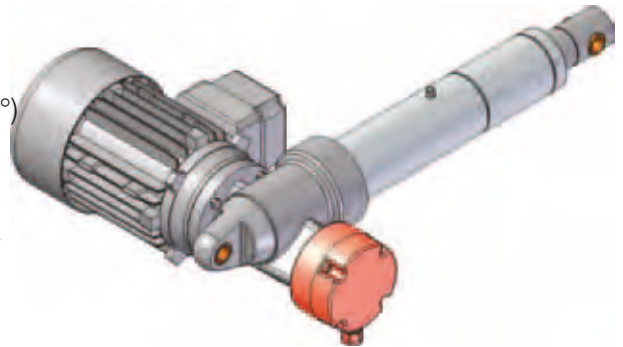

ACTUATOR	A [mm]
ATL – BSA 20	88
ATL – BSA 25	88
ATL – BSA 28	88
ATL – BSA 30	96
ATL – BSA 40	112

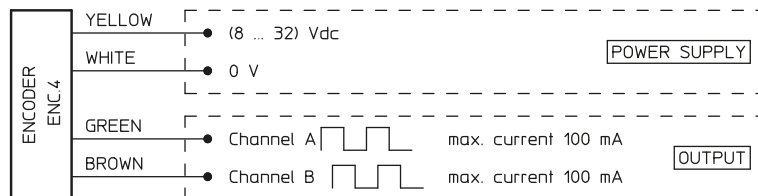

ROTARY ENCODER Code GI.2X (available only for ATL-BSA 30)

Hall-effect encoder, incremental, bi-directional
 Resolution: GI.21: 1 puls per revolution
 GI.24: 4 pulses per revolution
 Output: PUSH-PULL
 2 channels (A and B, phase difference 90°)
 Input voltage: (5 ... 24) Vdc, max. 25 Vdc
 No-load current: 5 mA
 Max. commutable current: 50 mA
 Protection:
 against input overvoltage peaks
 against input polarity inversion
 Cable length: 1.5 m

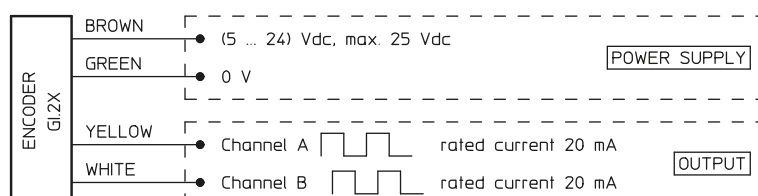
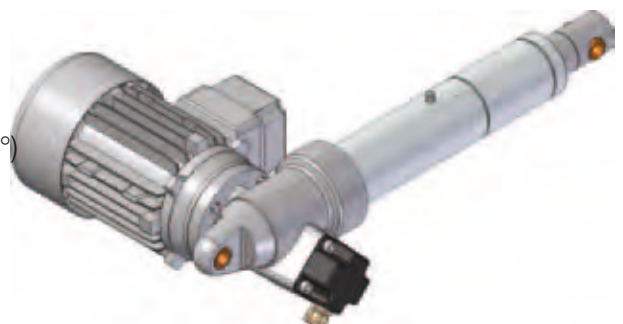

Linear actuators ATL Series and BSA Series

2.5 ACCESSORIES

ROTARY ENCODER Code EH 53

Optical encoder, incremental, bi-directional

Resolution: 100 or 500 pulses per revolution

Output: PUSH-PULL
2 channels (A and B, phase difference 90°)
channel ZERO

Input voltage: (8 ... 24) Vcc

No-load current: 100 mA

Max. commutable current: 50 mA

Cable length: 0.5 m

Protection: IP 54

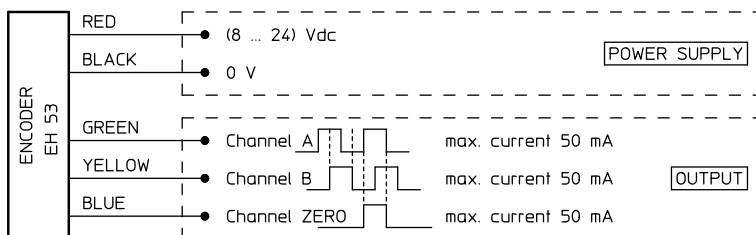
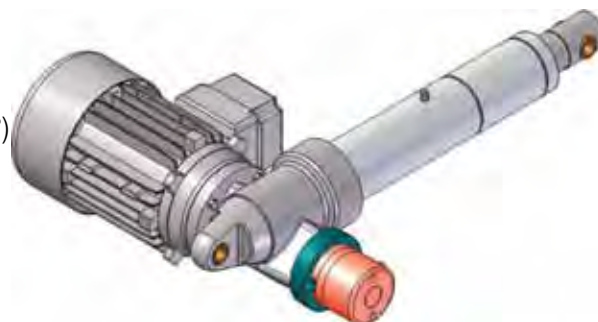

2.6 SPECIAL DESIGNS

According to specific application requirements, special designs can be carried out on standard actuators.

Some possible options are for example:

- push rod in stainless steel AISI 304
- outer tube in stainless steel AISI 304
- lubricants for high or low ambient temperature
- lubricants suitable for food industry
- seals in VITON or silicone
- wiper seal on push rod with second lip in brass (ice scrapers)

Thanks to the long experience and know-how, SERVOMECH is able to support customers in selecting the right actuator version and accessories suitable for specific environment and installation conditions.

Linear actuators ATL Series and BSA Series

2.7 ORDERING CODE

ATL	30	RN2	C300	FO	—	FCE	Vers. 3	RH
1	2	3	4	5	6	7	8.A	8.B

SP	FS
9	

AC 3-phase brake-motor	0.18 kW	4-pole	230/400 V	50 Hz	IP 55	Ins. F	W
10.A							10.B

1	Actuator series ATL or BSA	
2	Actuator size 20, 25, 28, 30, 40, 50, 63, 80, 100, 125	pages 42 ... 45
3	Ratio RH1, RV1, RN1, RL1, RXL1 RH2, RV2, RN2, RL2, RXL2	pages 42 ... 45
4	Stroke code C100, C200, C300, C400, C500, C600, C700, C800 (special stroke available on request)	
5	Front attachment BA - standard head with threaded bore ROE - rod end FO - clevis end TS - ball joint FL - flange end TF - hinged head	pages 54 ... 81
6	Position of front and rear actuator attachment STANDARD (without code) or RPT 90°	page 82
7	Stroke end switches FCE - electric stroke length limit device FC - electric switches FCM-NC - magnetic reed switches, normally closed FCM-NO - magnetic reed switches normally open FCP - inductive proximity switches	page 88 page 89 page 90 page 90 page 92
8.A	Actuator input Vers.1 - single input shaft Vers.2 - double input shaft Vers.3 - attachment for IEC motor (flange and hollow shaft) Vers.4 - attachment for IEC motor (flange and hollow shaft) + second shaft Vers.5 - attachment for IEC motor (adapter and coupling) Vers.6 - attachment for IEC motor (adapter and coupling) + second shaft	pages 83 ... 87
8.B	Motor mounting side - main input drive side RH (standard) or LH	page 82
9	Accessories SP - rear bracket FI - intermediate support flange AR - anti-turn device FS - safety clutch MS - safety nut for push load B - bellows encoder - EH 53 or ENC.4 or GI.2X or according to required specifications	pages 54 ... 81 page 82 page 93 page 93 page 94 page 94 pages 95 ... 96
10.A	Motor data	pages 200 ... 201
10.B	Motor terminal box position	page 82
11	Other specifications example: push rod in stainless steel AISI 304 example: lubricant for low temperature	
12	Filled in SELECTION DATA sheet	page 98 ... 99
13	Application layout	

APPLICATION: _____

REQUIRED STROKE: _____ mm

REQUIRED LINEAR SPEED: _____ mm/s _____ mm/min _____ m/min TIME TO PERFORM 1 STROKE: _____ s

STATIC LOAD: PULL: _____ N PUSH: _____ N at STROKE _____ mm

DYNAMIC LOAD: PULL: _____ N PUSH: _____ N at STROKE _____ mm

ACTUATOR SUBJECTED TO VIBRATIONS NOT SUBJECTED TO VIBRATIONS

OPERATING: _____ cycle / hour _____ working hours / day Notes: _____

REQUIRED LIFETIME: _____ cycle _____ hours _____ calendar days Notes: _____

ENVIRONMENT: TEMPERATURE _____ °C DUST HUMIDITY _____ % AGGRESSIVE AGENT _____

Acme screw actuators **ATL Series**

Ball screw actuators **BSA Series**

Size:

20

25

28

30

40

Ratio:

RH2

RH1

RV2

RV1

RN2

RN1

RL2

RL1

RXL2

RXL1

BA

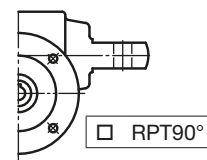
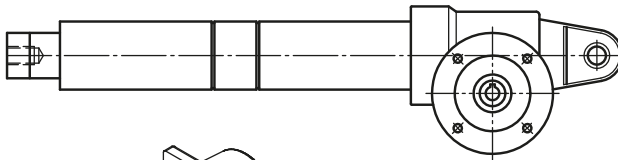

RPT90°

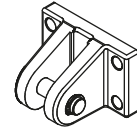

SP

ROE

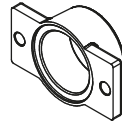

FI

FO

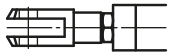

MOTOR MOUNTING SIDE
 MAIN INPUT SIDE
 LEFT-HAND (LH)

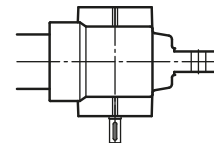

Vers.1

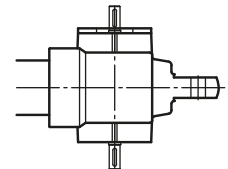

Vers.2

TS

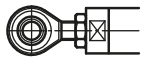

FL

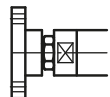

MOTOR MOUNTING SIDE
 MAIN INPUT SIDE
 RIGHT-SIDE (RH)

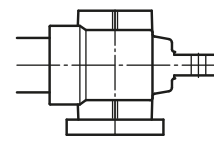

Vers.3

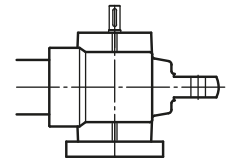

Vers.4

ELECTRIC MOTOR AC 3-phase AC 1-phase DC 24 V or 12 V WITHOUT BRAKE WITH BRAKE

STROKE END SWITCHES ELECTRIC FCE MAGNETIC FCM PROXIMITY FCP

ANTI-TURN DEVICE AR SAFETY CLUTCH FS SAFETY NUT MS

BELLOWS PUSH ROD IN STAINLESS STEEL OUTER TUBE IN STAINLESS STEEL

POSITIONING CONTROL WITH ROTARY ENCODER LINEAR TRANSDUCER

OTHER: _____

APPLICATION: _____

REQUIRED STROKE: _____ mm

REQUIRED LINEAR SPEED: _____ mm/s _____ mm/min _____ m/min TIME TO PERFORM 1 STROKE: _____ s

STATIC LOAD: PULL: _____ N PUSH: _____ N at STROKE _____ mm

DYNAMIC LOAD: PULL: _____ N PUSH: _____ N at STROKE _____ mm

ACTUATOR SUBJECTED TO VIBRATIONS NOT SUBJECTED TO VIBRATIONS

OPERATING: _____ cycle / hour _____ working hours / day Notes: _____

REQUIRED LIFETIME: _____ cycle _____ hours _____ calendar days Notes: _____

ENVIRONMENT: TEMPERATURE _____ °C DUST HUMIDITY _____ % AGGRESSIVE AGENT _____

Acme screw actuators **ATL Series**

Ball screw actuators **BSA Series**

Size: 50 63 80 100 125

Ratio: RV2 RV1 RN2 RN1 RL2 RL1 RXL2 RXL1

BA

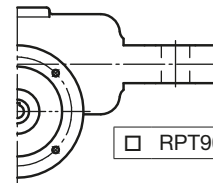
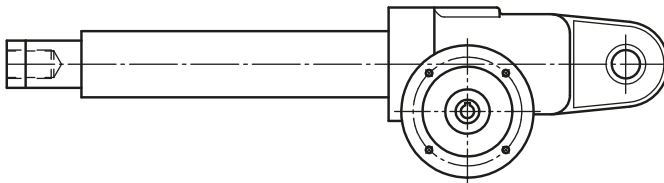

RPT90°

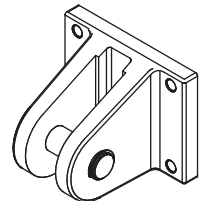

SP

TF



MOTOR MOUNTING SIDE
 MAIN INPUT SIDE
 LEFT-HAND (LH)

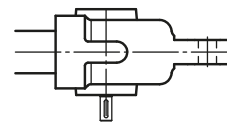
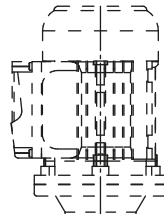

Vers.1

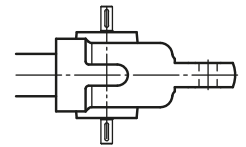

Vers.2

TS

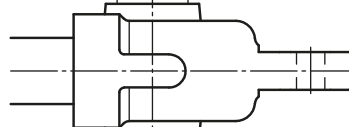
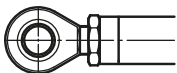

Vers.3

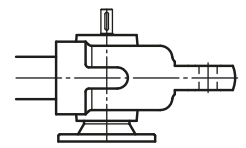

Vers.4

FL

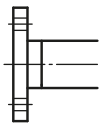

MOTOR MOUNTING SIDE
 MAIN INPUT SIDE
 RIGHT-SIDE (RH)

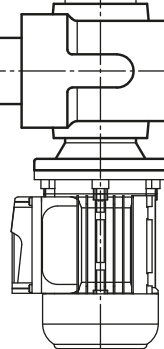

Vers.5

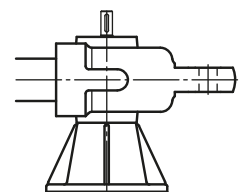

Vers.6

ELECTRIC MOTOR AC 3-phase _____ WITHOUT BRAKE WITH BRAKE

STROKE END SWITCHES ELECTRIC FCE PROXIMITY FCP ELECTRIC FC

ANTI-TURN DEVICE AR SAFETY CLUTCH FS SAFETY NUT MS

BELLOWS PUSH ROD IN STAINLESS STEEL OUTER TUBE IN STAINLESS STEEL

POSITIONING CONTROL WITH ROTARY ENCODER LINEAR TRANSDUCER

OTHER: _____

Acme screw actuators **ATL Series**

Ball screw actuators **BSA Series**

PRODUCT: _____

Product serial number: _____ ; q.ty: _____

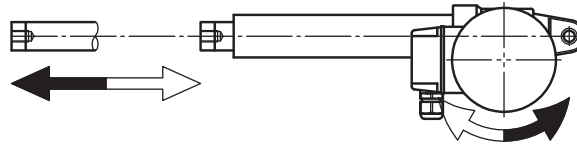

STANDARD HEAD

BA

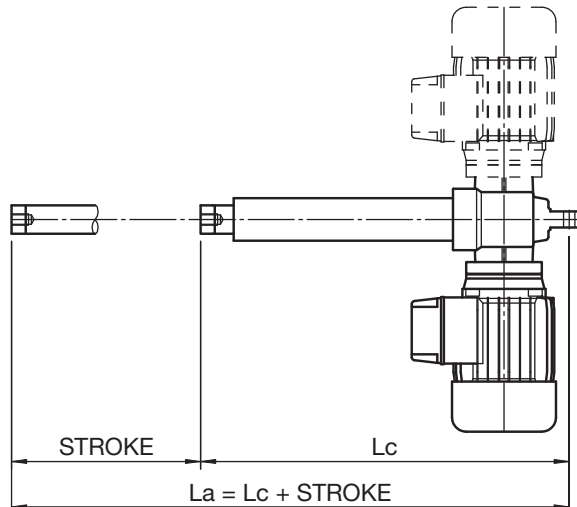

LEFT-HAND MOUNTING

RIGHT-HAND MOUNTING

CLEVIS END

FO

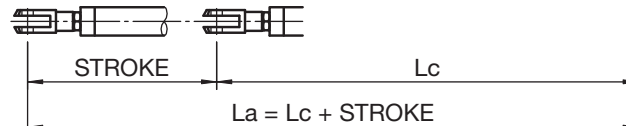

BALL JOINT

TS

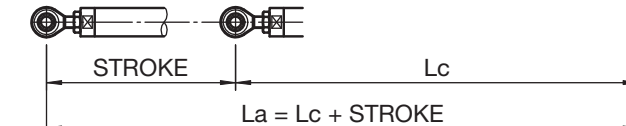

FLANGE END

FL

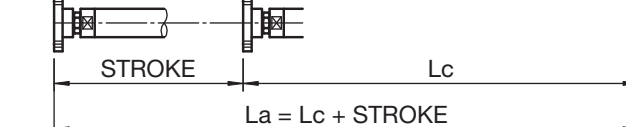

ROD END

ROE

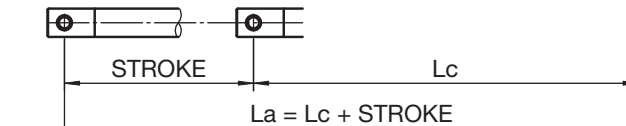

HINGED HEAD

TF

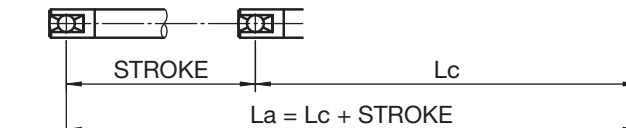

ELECTRIC MOTOR

- AC 3-phase
- AC 1-phase
- DC
- WITHOUT brake
- WITH brake
 - internally powered
 - separately powered

Servomech. QMS

PASSED

Date: _____

Signature: _____

LINEAR ACTUATOR LENGTH (ref. to BA ROE TF FL)

WORKING RANGE

RETRACTED ACTUATOR length: $L_c =$ _____ mm

EXTENDED ACTUATOR length: $L_a =$ _____ mm

STROKE ($L_a - L_c$): $C =$ _____ mm

INTERNAL MECHANICAL STOP LIMIT

MIN. actuator length: _____ mm

MAX. actuator length: _____ mm

ELECTRIC STROKE END DEVICE **FCE** □

The ELECTRIC STROKE END DEVICE **FCE** is activated by microswitches FC 1 and FC 2.

- contact: **normally CLOSED**
- voltage: 250 V AC / 30 V DC
- current: 5 A (resistive load)
3 A (inductive load)

The RETRACTED ACTUATOR position is set by the adjustable ring 1. The wires that connect the switch FC 1 are WHITE and BROWN.

The EXTENDED ACTUATOR position is set by the adjustable ring 2. The wires that connect the switch FC 2 are GREEN and YELLOW.

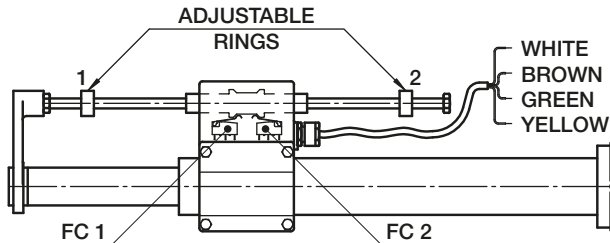

MAGNETIC STROKE END SWITCHES **FCM** □

The MAGNETIC STROKE END SWITCHES **FCM** has reed switches FC 1 and FC 2.

The rated electric values are indicated on the reed switch.

The RETRACTED ACTUATOR position is adjusted and controlled by FC 1.

The EXTENDED ACTUATOR position is adjusted and controlled by FC 2.

Reed switch wires are BROWN and BLUE (and the third, BLACK, for change-over contact).

For DC supply: connect the BROWN wire to ⊕.

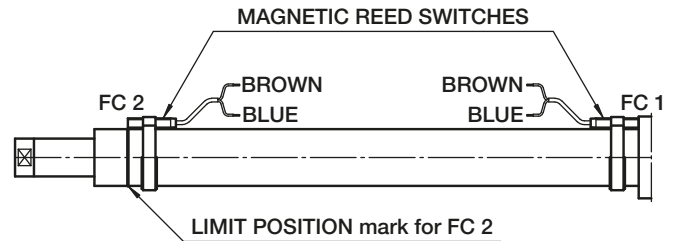

PROXIMITY STROKE END SWITCHES **FCP** □

The PROXIMITY STROKE END SWITCHES **FCP** has proximity sensors FC 1 and FC 2.

- type: inductive, PNP
- contact: **normally CLOSED**
- supply voltage: (10 ... 30) V DC
- max. output current: 200 mA
- max. voltage drop (activated sensor): < 3 V (ref. 200 mA)

FC 1 - sensor for RETRACTED ACTUATOR position

FC 2 - sensor for EXTENDED ACTUATOR position

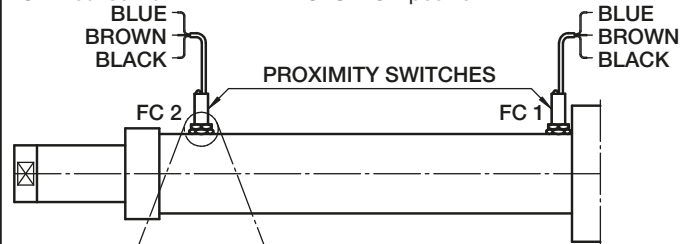

ACTUATOR	P [mm]
ATL-BSA 50	3.5
ATL-BSA 63	
ATL-BSA 80	



ELECTRIC STROKE END SWITCHES **FC** □

The ELECTRIC STROKE END SWITCHES **FC** has miniature switches FC 1 and FC 2.

- contact: **normally CLOSED**
- supply voltage: 250 V AC / 125 V AC / 125 V DC
- current: 16 A / 16 A / 0.6 A (resistive load)
10 A / 10 A / 0.6 A (inductive load)

FC 1 - switch for RETRACTED ACTUATOR position

The wires that connect the switch FC 1 are WHITE and BROWN.

FC 2 - switch for EXTENDED ACTUATOR position

The wires that connect the switch FC 2 are GREEN and YELLOW.

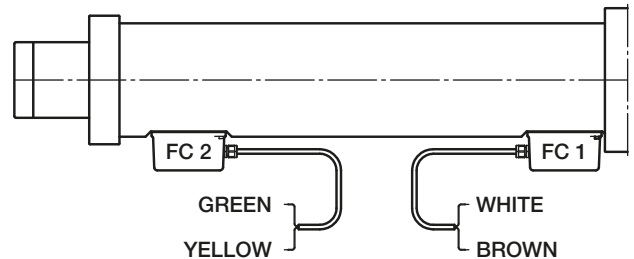

SINGLE SWITCH WIRING:

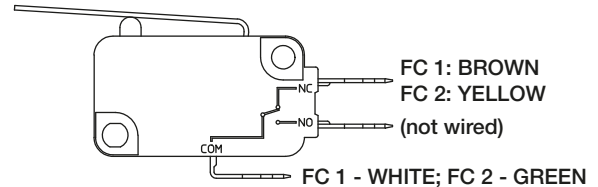

WARNING!

1. The values **Lc** (RETRACTED ACTUATOR length), **La** (EXTENDED ACTUATOR length) and **C** (STROKE) are the extreme limit values.
2. **BEFORE** using the linear actuator:
 - verify the input shaft rotation direction and the push rod running direction;
 - check the stroke end switches position: they must not exceed the extreme limit positions;
 - make sure that the motor and the limit switches are correctly connected and that the right voltage is used.
3. Linear actuators equipped with brake motor:
 - the brake is **NORMALLY CLOSED** (NEGATIVE action). When the power supply is switched off, the brake is engaged. The brake opens only when power is supplied;
 - if the brake is wired directly to the connecting pins of the terminal box, it does not require any power supply;
 - if the brake is wired separately, make sure that the correct voltage is used;
 - if the brake is equipped with hand release device, make sure that the brake is engaged before starting the linear actuator.
4. **Alignment check:** the load must be in line with the actuator. No off-set or radial loads are allowed.

WORMGEAR LUBRICANT: _____

SCREW – NUT LUBRICANT: _____

Linear actuators CLA Series and CLB Series

3

CLA-CLB Series, size 30 - 40

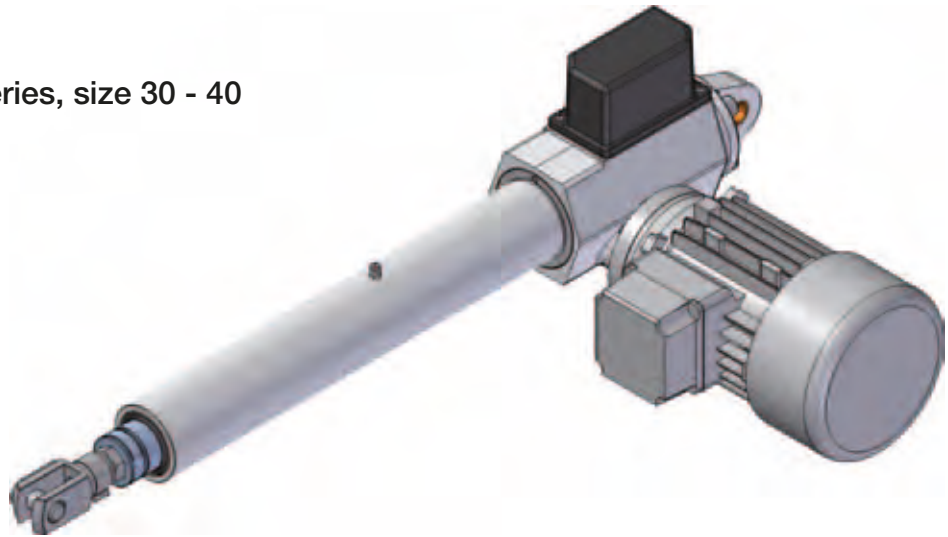

CLA-CLB Series, size 50

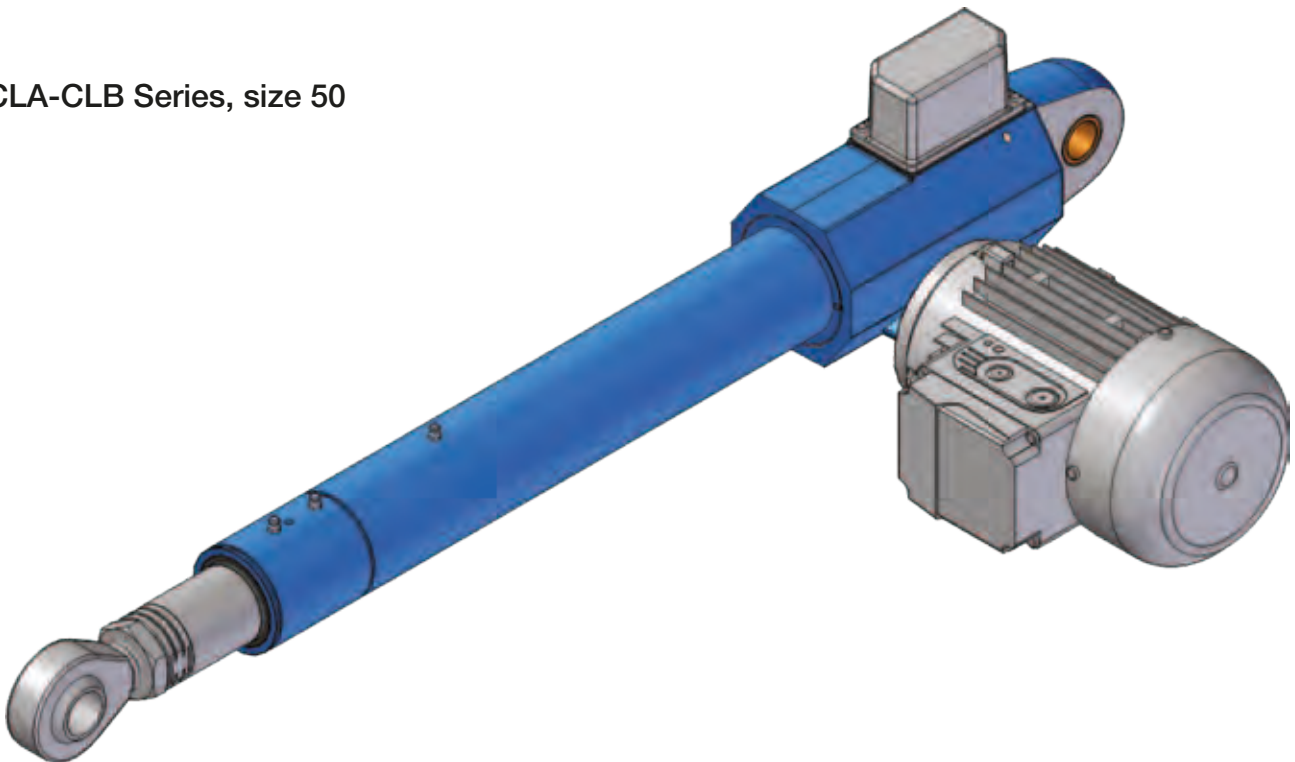

Linear actuators CLA Series and CLB Series

3.1 MANUFACTURING FEATURES

Input drive: worm gear - precision helical wheel, geometric design for high performance, involute profile ZI (UNI 4760 : Part 4), low angular backlash. Worm in case hardened steel 20 MnCr 5 (UNI EN 10084), with thread and input shafts ground. Helical wormwheel in bronze EN 1982 – CuSn12-C.

Housing: designed and manufactured in monobloc form to obtain a compact body able to sustain heavy axial loads and high machining accuracy. High quality materials are used:

- castings in aluminium alloy EN 1706 AC-ALSi6Cu4
- castings in grey cast iron EN-GJL-250 (UNI EN 1561).

Acme screw:

- ISO trapezoidal thread ISO 2901 ... ISO 2904
- material: steel C 43 (UNI 7847)
- rolled or whirled
- subjected to straightening, to ensure accurate alignment in operation
- max. pitch error ± 0.05 mm over 300 mm length

Bronze nut:

- ISO trapezoidal thread ISO 2901 ... ISO 2904
- material: bronze EN 1982 – CuAl9-C (1-start thread)
- material: bronze EN 1982 – CuSn12-C (multiple start thread)
- max. axial backlash for new nut (0.10 ... 0.12) mm

Outer tube:

- material: aluminium alloy EN AW-6060 thick cold-drawn tube anodized ARC 20 (UNI 4522/66) inner diameter tolerance ISO H9
- steel St 52.2 (DIN 2391) cold-drawn tube inner diameter tolerance ISO H10 ... H11

Bearings:

- on motor axis: radial ball bearings
- on actuator axis: radial ball bearings or angular contact ball bearings, to avoid axial backlash and to assure high push-pull load capacity

Front attachment:

- standard – with threaded hollow bore, in stainless steel AISI 303 or steel C 43 (UNI 7847)

Rear bracket:

- in aluminium alloy for CLA-CLB 30, 40
- in grey cast iron for CLA-CLB 50
- pin in stainless steel AISI 303

Electric stroke end switches FC:

- cam-operated electric switches
- cover in thermoplastic material for CLA-CLB 30 and 40, in aluminium alloy for CLA-CLB 50
- drive transmission in brass OT 58 (UNI 5705/65)

Ball screw:

- designed and manufactured by SERVOMECH
- rolled and hardened material: steel 42 CrMo 4 (UNI EN 10083) accuracy grade: ISO IT 7
- hardened and machined material: steel 42 CrMo 4 (UNI EN 10083) accuracy grade: ISO IT 5

Ball nut:

- designed and manufactured by SERVOMECH
- material: steel 18 NiCrMo 5 (UNI EN 10084), case hardened
- max. axial backlash (0.07 ... 0.08) mm
- on request, ball nut with ZERO backlash or pre-loaded using selected diameter balls

Push rod:

- material: steel St 52 (DIN 2391) thick tube chrome-plated, min. chrome thickness 5/100 mm inner diameter tolerance ISO f7
- push rod in stainless steel INOX AISI 304 or special stainless steel on request

Linear actuators CLA Series

3.2 TECHNICAL DATA - acme screw linear actuators CLA Series

SIZE		CLA 30	CLA 40	CLA 50	
Push rod diameter	[mm]	35	40	50	
Outer tube diameter	[mm]	55	60	70	
Front attachment diameter	[mm]	14	20	30	
Rear attachment diameter	[mm]	14	20	30	
Attachment for IEC standard motor (flange and hollow shaft)		63 B14	71 B14	71 B14	
Attachment for IEC standard motor (flange adapter + coupling)		—	—	80 B14	
Max. dynamic load	[N]	10 000	12 000	25 000	
Max. static load	pull [N]	10 000	12 000	25 000	
	push [N]	12 000	15 000	25 000	
Ratio	RV	1 : 4 (4 : 16)	1 : 5 (4 : 20)	1 : 5 (4 : 20)	
	RN	1 : 16 (2 : 32)	1 : 20	1 : 20	
	RL	1 : 24	1 : 25	1 : 25	
	RXL	1 : 34	1 : 55	1 : 55	
1-start acme screw		Tr 18×4	Tr 22×5	Tr 30×6	
Linear travel [mm] for 1 input shaft revolution	Ratio				
	RV1	1	1	1.2	
	RN1	0.25	0.25	0.3	
	RL1	0.17	0.2	0.24	
	RXL1	0.12	0.09	0.11	
2-start acme screw		Tr 18×8 (P4)	Tr 22×10 (P5)	Tr 30×12 (P6)	
Linear travel [mm] for 1 input shaft revolution	Ratio				
	RV2	2	2	2.4	
	RN2	0.5	0.5	0.6	
	RL2	0.33	0.4	0.28	
	RXL2	0.24	0.18	0.22	
Mass (actuator 100 mm stroke length, without motor, with lubricant)		[kg]	3.8	6.5	16
Extra-mass for each additional 100 mm stroke length		[kg]	0.8	0.8	2

Linear actuators CLB Series

3.2 TECHNICAL DATA - ball screw linear actuators CLB Series

SIZE		CLB 30	CLB 40	CLB 50	
Push rod diameter	[mm]	35	40	50	
Outer tube diameter	[mm]	55	60	70	
Front attachment diameter	[mm]	14	20	30	
Rear attachment diameter	[mm]	14	20	25	
Attachment for IEC standard motor (flange and hollow shaft)		63 B14	71 B14	71 B14	
Attachment for IEC standard motor (flange adapter + coupling)		—	—	80 B14	
Max. dynamic load	[N]	9 000	12 000	25 000	
Max. static load	pull [N]	10 000	12 000	25 000	
	push [N]	12 000	15 000	25 000	
Ratio	RV	1 : 4 (4 : 16)	1 : 5 (4 : 20)	1 : 5 (4 : 20)	
	RN	1 : 16 (2 : 32)	1 : 20	1 : 20	
	RL	1 : 24	1 : 25	1 : 25	
	RXL	1 : 34	1 : 55	1 : 55	
Ball screw (STANDARD)	Diameter × Lead		20×5	25×6	32×10
	Ball	[mm]	3.175 (1/8 ")	3.969 (5/32 ")	6.350 (1/4 ")
	N° of circuits		3	3	4
	Dynamic load C _a	[N]	12 000	17 400	41 800
	Static load C _{0a}	[N]	21 200	30 500	73 000
Linear travel [mm] for 1 input shaft revolution	Ratio	RV1	1.25	1.2	2
		RN1	0.31	0.3	0.5
		RL1	0.24	0.24	0.4
		RXL1	0.15	0.11	0.18
Mass (actuator 100 mm stroke length, without motor, with lubricant)		[kg]	3.8	6.5	19
Extra-mass for each additional 100 mm stroke length		[kg]	0.8	0.9	2

ON REQUEST

Ball screw (Diameter × Lead)		20×10	25×10	32×20
Ball	[mm]	3.175 (1/8 ")	3.969 (5/32 ")	6.35 (1/4 ")
N° of circuits		3	3	3
Dynamic load C _a	[N]	12 900	18 000	32 200
Static load C _{0a}	[N]	23 500	33 000	53 000

NOTE: When these ball screws are used, the actuator length will be increased.
Please, contact SERVOMECH to get information about the exact length.

Linear actuators CLA Series

ACME SCREW LINEAR ACTUATORS CLA Series with AC 3-PHASE MOTOR
 PERFORMANCE with: Duty Cycle $F_i = 30\%$ over 10 min at ambient temperature 25 °C

LINEAR SPEED [mm/s]	DYNAMIC LOAD [N]	RATIO	MOTOR: POWER [kW] — N° of POLES SPEED [rpm]	SELF-LOCKING COEFFICIENT
CLA 30				
46	2500 ¹⁾	RV1	0.25 kW 2-pole 2800	0.25
23	5200 ¹⁾	RN2	0.25 kW 2-pole 2800	0.28
15	6700 ¹⁾	RL2	0.25 kW 2-pole 2800	0.22
11	8500 ¹⁾	RXL2	0.25 kW 2-pole 2800	0.18
7.5	9700 ¹⁾	RL1	0.25 kW 2-pole 2800	0.16
5.5	10000 ²⁾	RXL1	0.25 kW 2-pole 2800	0.13
4	10000 ²⁾	RL1	0.18 kW 4-pole 1400	0.16
2.7	10000 ²⁾	RXL1	0.18 kW 4-pole 1400	0.13
CLA 40				
46	5400 ¹⁾	RV1	0.55 kW 2-pole 2800	0.26
23	10500 ¹⁾	RN2	0.55 kW 2-pole 2800	0.25
18	12000 ²⁾	RL2	0.55 kW 2-pole 2800	0.24
11	12000 ²⁾	RN1	0.55 kW 2-pole 2800	0.18
8.5	12000 ²⁾	RXL2	0.55 kW 2-pole 2800	0.17
5.5	12000 ²⁾	RN1	0.37 kW 4-pole 1400	0.18
4.5	12000 ²⁾	RL1	0.37 kW 4-pole 1400	0.17
2.1	12000 ²⁾	RXL1	0.37 kW 4-pole 1400	0.08
CLA 50				
56	9300 ¹⁾	RV1	1.1 kW 2-pole 2800	0.24
28	17900 ¹⁾	RN2	1.1 kW 2-pole 2800	0.23
22	20800 ¹⁾	RL2	1.1 kW 2-pole 2800	0.22
14	25000 ²⁾	RN1	1.1 kW 2-pole 2800	0.16
11	25000 ²⁾	RL1	1.1 kW 2-pole 2800	0.15
7	25000 ²⁾	RN1	0.75 kW 4-pole 1400	0.16
5.5	25000 ²⁾	RL1	0.75 kW 4-pole 1400	0.15
2.5	25000 ²⁾	RXL1	0.37 kW 4-pole 1400	0.08

ACME SCREW LINEAR ACTUATORS CLA Series with AC 1-PHASE MOTOR
 PERFORMANCE with: Duty Cycle $F_i = 30\%$ over 10 min at ambient temperature 25 °C

LINEAR SPEED [mm/s]	DYNAMIC LOAD [N]	RATIO	MOTOR: POWER [kW] — N° of POLES SPEED [rpm]	SELF-LOCKING COEFFICIENT
CLA 30				
46	2350 ¹⁾	RV1	0.25 kW 2-pole 2800	0.25
23	4800 ¹⁾	RN2	0.25 kW 2-pole 2800	0.28
15	6300 ¹⁾	RL2	0.25 kW 2-pole 2800	0.22
11	8000 ¹⁾	RXL2	0.25 kW 2-pole 2800	0.18
7.5	9200 ¹⁾	RL1	0.25 kW 2-pole 2800	0.16
5.5	10000 ²⁾	RXL1	0.25 kW 2-pole 2800	0.13
4	10000 ²⁾	RL1	0.18 kW 4-pole 1400	0.16
2.7	10000 ²⁾	RXL1	0.18 kW 4-pole 1400	0.13
CLA 40				
46	5400 ¹⁾	RV1	0.55 kW 2-pole 2800	0.26
23	10000 ¹⁾	RN2	0.55 kW 2-pole 2800	0.25
18	12000 ²⁾	RL2	0.55 kW 2-pole 2800	0.24
11	12000 ²⁾	RN1	0.55 kW 2-pole 2800	0.18
8.5	12000 ²⁾	RXL2	0.55 kW 2-pole 2800	0.12
5.5	12000 ²⁾	RN1	0.37 kW 4-pole 1400	0.18
4.5	12000 ²⁾	RL1	0.37 kW 4-pole 1400	0.17
2.1	12000 ²⁾	RXL1	0.37 kW 4-pole 1400	0.08

Linear actuators CLB Series

BALL SCREW LINEAR ACTUATORS CLB Series with AC 3-PHASE MOTOR PERFORMANCE with: Duty Cycle $F_i = 100\%$ at ambient temperature $25\text{ }^\circ\text{C}$

LINEAR SPEED [mm/s]	DYNAMIC LOAD [N]	RATIO	MOTOR: POWER [kW] — N° of POLES SPEED [rpm]	SELF-LOCKING COEFFICIENT
CLB 30				
60	3300 ¹⁾	RV1	0.25 kW 2-pole 2800	0.56
30	4350 ²⁾	RV1	0.18 kW 4-pole 1400	0.56
15	5500 ²⁾	RN1	0.25 kW 2-pole 2800	0.43
10	6300 ²⁾	RL1	0.25 kW 2-pole 2800	0.34
7	7000 ²⁾	RN1	0.18 kW 4-pole 1400	0.43
5	7900 ²⁾	RL1	0.18 kW 4-pole 1400	0.34
3.5	9000 ^{2) 3)}	RXL1	0.18 kW 4-pole 1400	0.30
CLB 40				
56	5400 ²⁾	RV1	0.55 kW 2-pole 2800	0.56
28	6800 ²⁾	RV1	0.37 kW 4-pole 1400	0.56
14	8600 ²⁾	RN1	0.55 kW 2-pole 2800	0.38
11	9250 ²⁾	RL1	0.55 kW 2-pole 2800	0.36
7	10800 ²⁾	RN1	0.37 kW 4-pole 1400	0.38
5.5	11600 ²⁾	RL1	0.37 kW 4-pole 1400	0.36
2.5	12000 ³⁾	RXL1	0.37 kW 4-pole 1400	0.20
CLB 50				
47	11800 ¹⁾	RV1	0.75 kW 4-pole 1400	0.56
23	20500 ²⁾	RN1	1.1 kW 2-pole 2800	0.38
19	22000 ²⁾	RL1	1.1 kW 2-pole 2800	0.36
12	25000 ³⁾	RN1	0.75 kW 4-pole 1400	0.38
9.3	25000 ³⁾	RL1	0.37 kW 4-pole 1400	0.36
4.2	25000 ³⁾	RXL1	0.37 kW 4-pole 1400	0.20

1) value limited by electric motor power; ball screw lifetime $L_{10h} > 1000$ hours (see diagrams on pages 34 ... 35)

The total dynamic efficiency (η) of CLB Series actuators, used to determine the DYNAMIC LOAD is calculated as follows:

$$\eta = \eta_1 \times \eta_2 \times \eta_3$$

where:

η_1 – wormgear dynamic efficiency, calculated according to BS 721 : Part 2 : 1983

$\eta_2 = 0.9$ – ball screw - nut efficiency

$\eta_3 = 0.9$ – bearings and sealing elements "efficiency"

2) value related to the ball screw lifetime $L_{10h} = 1000$ h, with constant load, without load vibrations nor shocks; for different lifetime refer to diagrams on pages 34 ... 35

3) limit value of linear actuator dynamic load capacity (see page 105)

Notes regarding the tables at page 106 (linear actuators CLA Series):

1) value limited by electric motor power

The total dynamic efficiency (η) of CLA Series actuators, used to determine the DYNAMIC LOAD is calculated as follows:

$$\eta = \eta_1 \times \eta_2 \times \eta_3$$

where:

η_1 – wormgear dynamic efficiency, calculated according to BS 721 : Part 2 : 1983

η_2 – acme screw-bronze nut dynamic efficiency, calculated with reference to the speed

$\eta_3 = 0.9$ – bearings and sealing elements "efficiency"

2) limit value of linear actuator dynamic load capacity (see page 104)

Linear actuators CLA Series

3.4 OVERALL DIMENSIONS

ACME SCREW LINEAR ACTUATORS CLA Series, size 30 – 40
AC 3-phase or 1-phase MOTOR

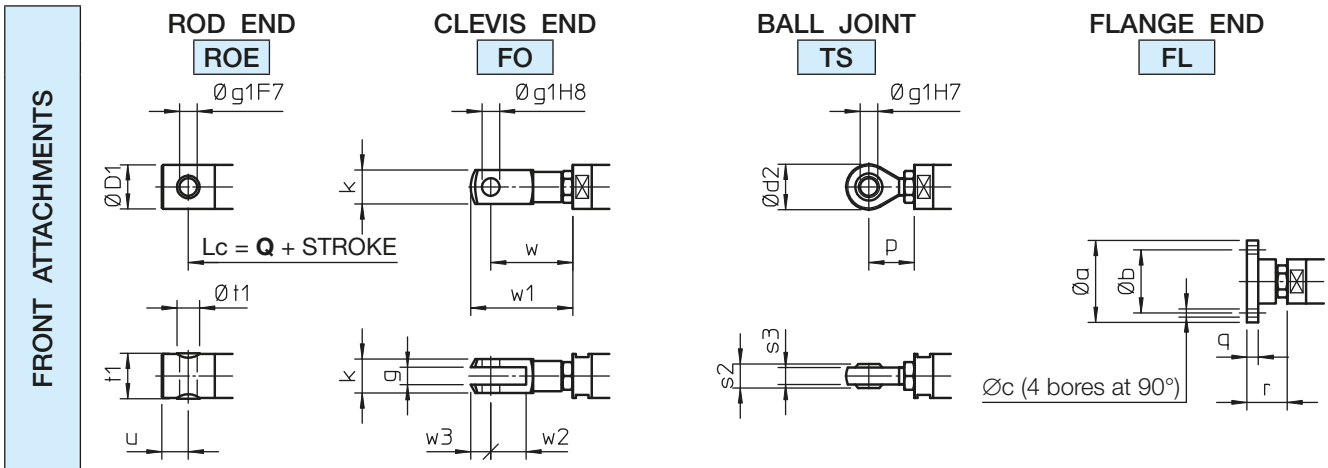
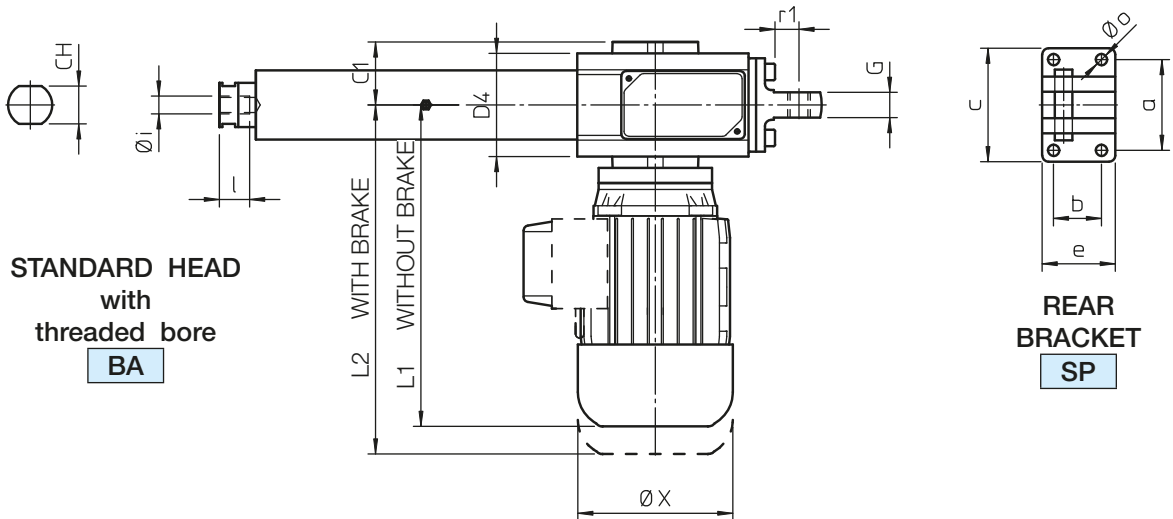
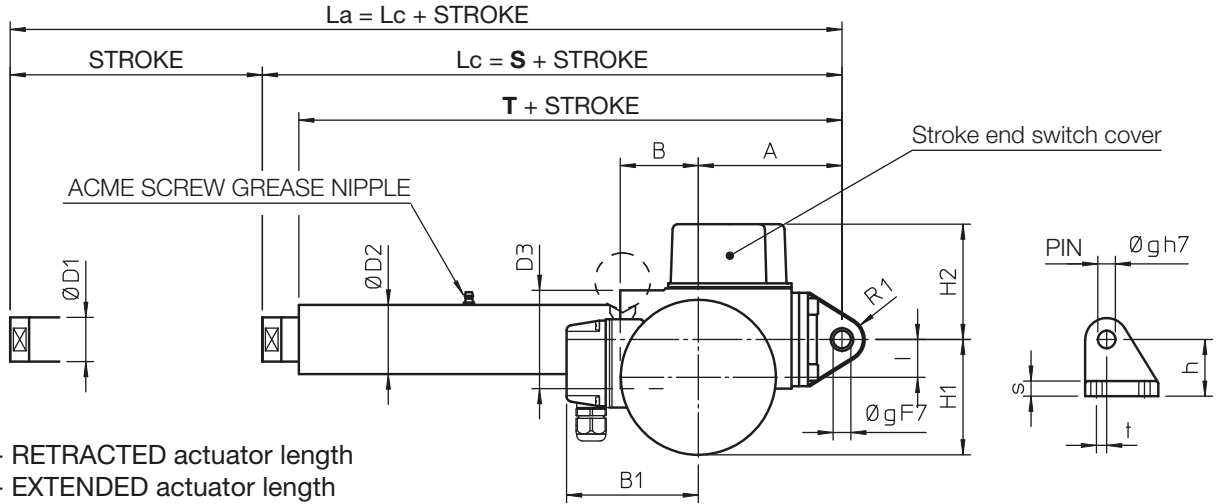

Linear actuators CLA Series

3.4 OVERALL DIMENSIONS

ACME SCREW LINEAR ACTUATORS CLA Series, size 30 – 40 AC 3-phase or 1-phase MOTOR

	STROKE CODE	C...	S	T	Q
CLA 30	STROKE [mm] = STROKE CODE	...	260	231	266
CLA 40			304	266	316

ACTUATOR with FC in STANDARD execution	MAX. stroke [mm]
CLA 30 R_1	500
CLA 30 R_2	800
CLA 40 R_1	600
CLA 40 R_2	800

NOTE: Greater stroke lengths available on request.

For stroke lengths longer than 800 mm it is necessary to increase the guided length between push rod and outer tube to avoid axial backlash. Dimensions **S**, **T** and **Q** shall be considered increased by 200 mm for stroke lengths up to 1500 mm.

	A	B	B1	C1	CH	∅ D1	∅ D2	D3	D4	G	H1	H2	I	L1	L2
CLA 30	114	62	115	54	30	35	55	78	82	20	92	92	30	255	291
CLA 40	128.5	78	124	61	36	40	60	92	103	24	111	99	40	284	373

	R1	∅ X	a	b	c	e	∅ g	h	∅ i	l	∅ o	r1	s	t
CLA 30	18	123	72	38	90	58	14	45	M14×2	24	9	20	12	8
CLA 40	28	150	85	55	110	81	20	58	M20×1.5	27	11	32	15	15

FRONT ATTACHMENT Dimensions

	∅ a	∅ b	∅ c	∅ D1	∅ d2	g	∅ g1	k	p	p1
CLA 30	65	50	6.5	35	36	14	14	27	36	54
CLA 40	80	60	8.5	40	50	20	20	40	53	78

	q	r	s2	s3	t1	∅ t1	u	w	w1	w2	w3
CLA 30	9	32	19	14	36	18	21	65	81	28	16
CLA 40	10	42	25	18	42	25	27	90	115	40	25

Linear actuators CLB Series

3.4 OVERALL DIMENSIONS

BALL SCREW LINEAR ACTUATOR CLB 50 AC 3-phase MOTOR

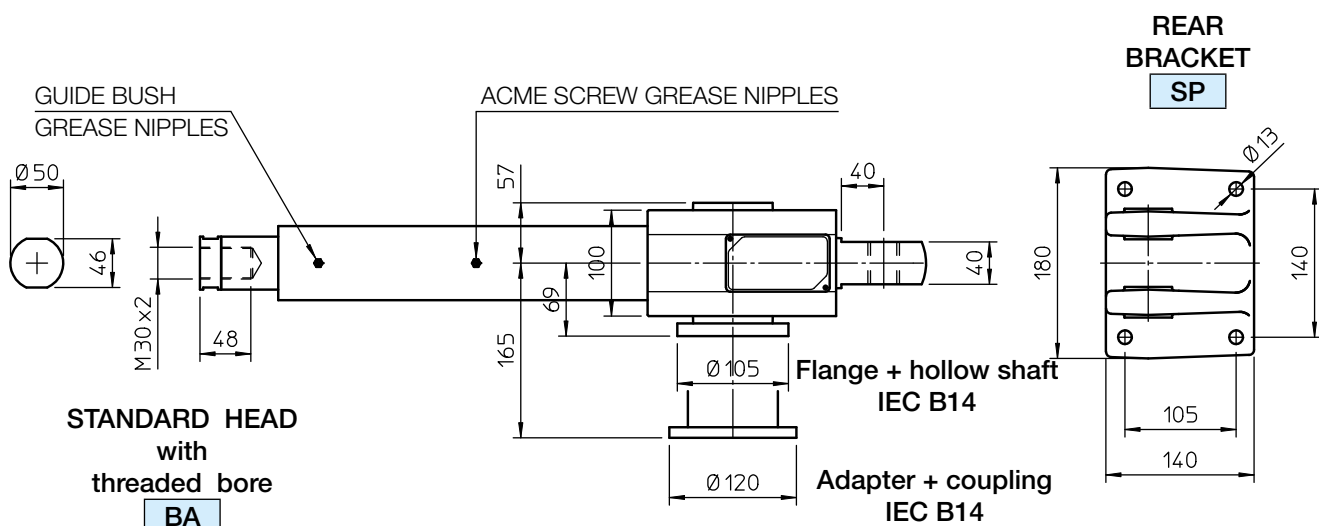
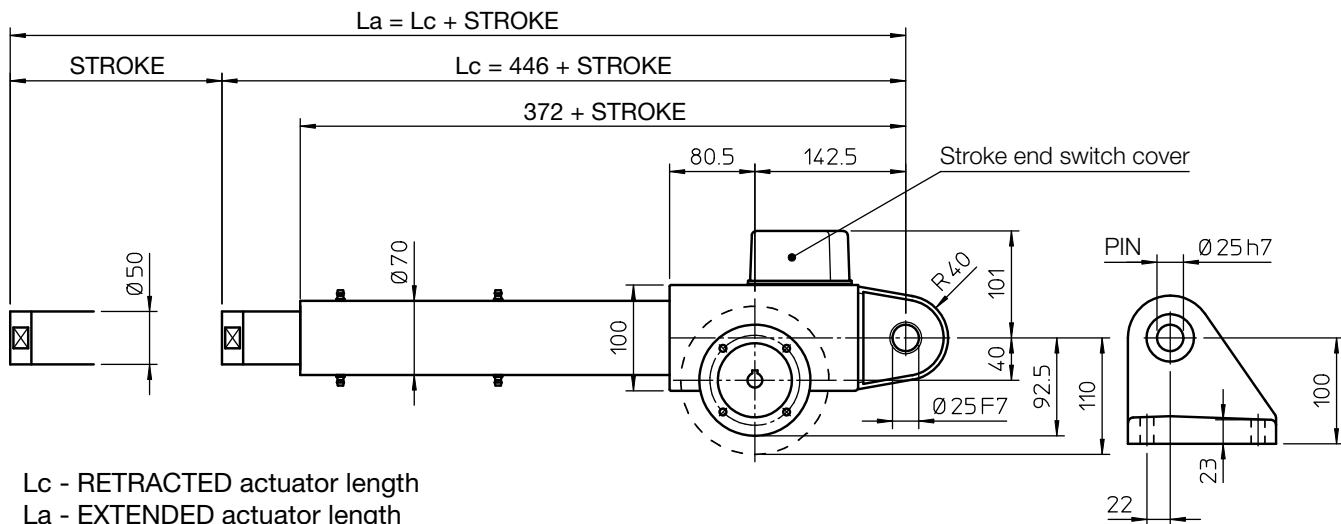

FRONT ATTACHMENTS

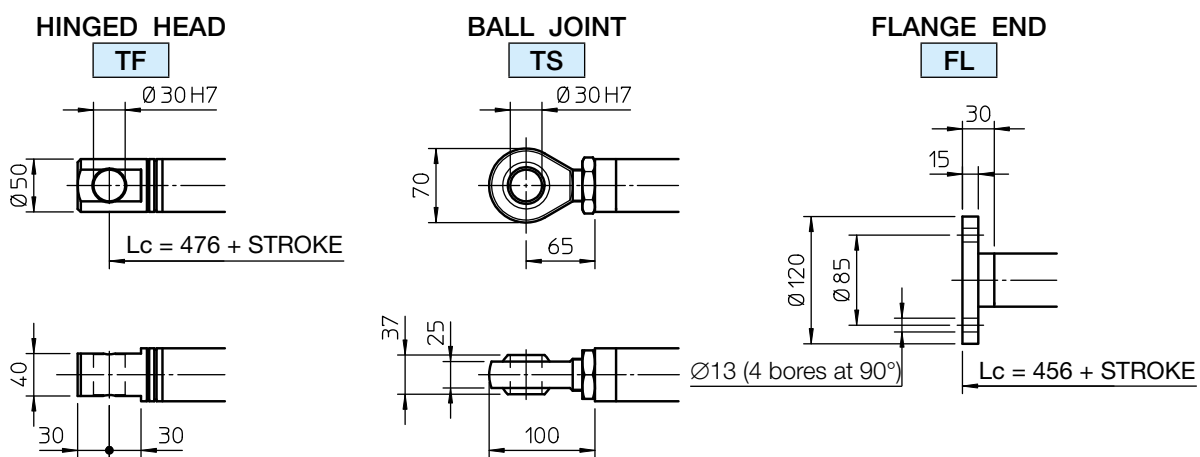

NOTE: For stroke lengths longer than 800 mm it is necessary to increase the guided length between push rod and outer tube to avoid axial backlash. The tube length and the dimensions **Lc** and **La** shall be considered increased by 200 mm for stroke lengths up to max. 1500 mm.

Linear actuators CLB Series

3.4 OVERALL DIMENSIONS

BALL SCREW LINEAR ACTUATORS CLB Series, size 30 – 40 AC 3-phase MOTOR

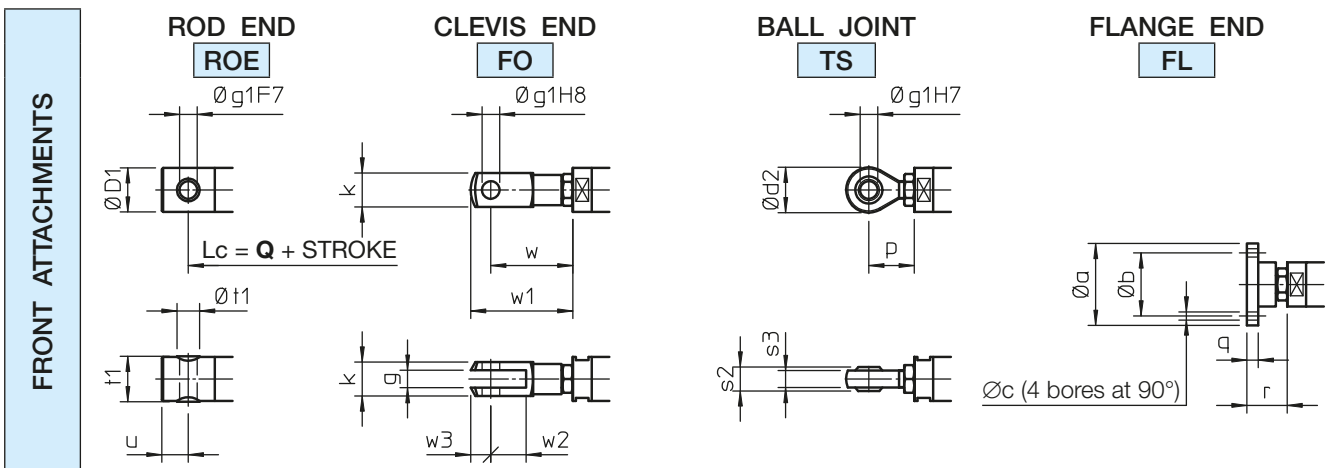
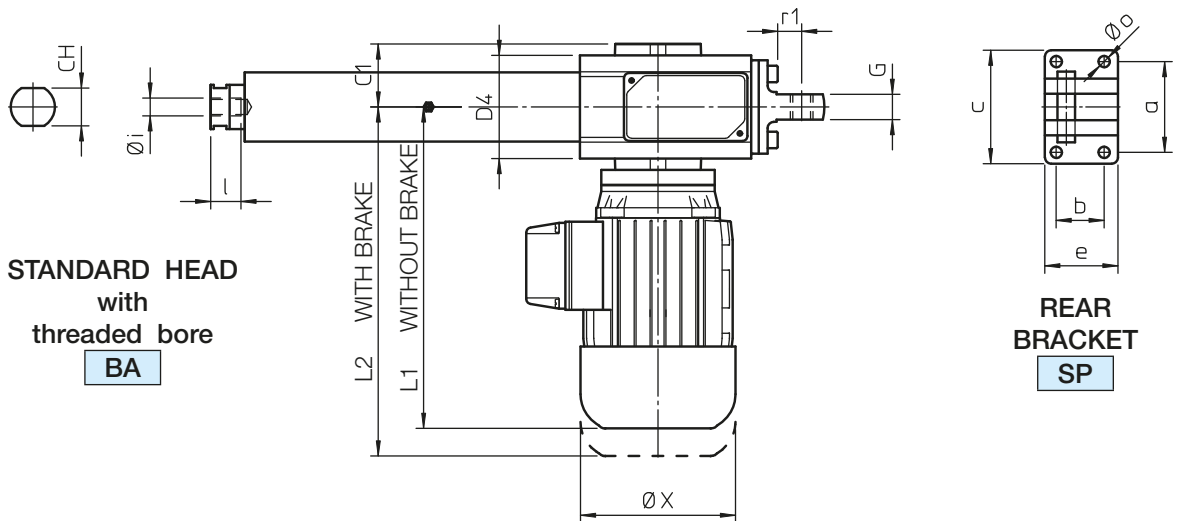
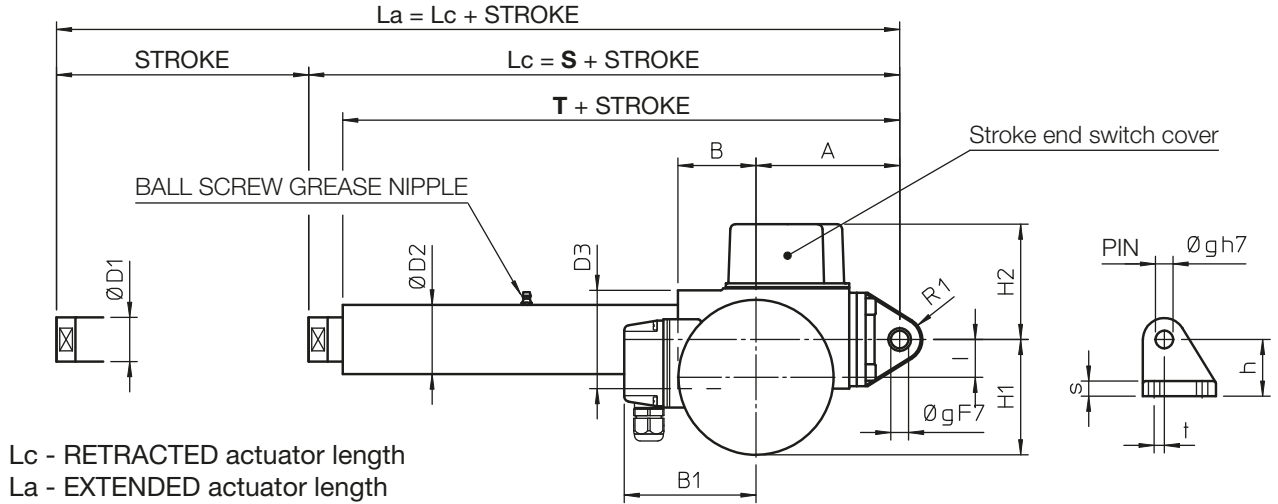

Linear actuators CLB Series

3.4 OVERALL DIMENSIONS

BALL SCREW LINEAR ACTUATORS CLB Series, size 30 – 40 AC 3-phase MOTOR

	STROKE CODE	C...	S	T	Q
CLB 30	STROKE [mm] = STROKE CODE	...	269	242	275
CLB 40			313	278	325

ACTUATOR with FC in STANDARD execution	MAX. stroke [mm]
CLB 30	600
CLB 40	800

NOTE: Greater stroke lengths available on request.

For stroke lengths longer than 800 mm it is necessary to increase the guided length between push rod and outer tube to avoid axial backlash. Dimensions **S**, **T** and **Q** shall be considered increased by 200 mm for stroke lengths up to 1500 mm.

	A	B	B1	C1	CH	∅ D1	∅ D2	D3	D4	G	H1	H2	I	L1	L2
CLB 30	114	62	115	54	30	35	55	78	82	20	92	92	30	255	291
CLB 40	128.5	78	124	61	36	40	60	92	103	24	111	99	40	284	373

	R1	∅ X	a	b	c	e	∅ g	h	∅ i	l	∅ o	r1	s	t
CLB 30	18	123	72	38	90	58	14	45	M14x2	24	9	20	12	8
CLB 40	28	150	85	55	110	81	20	58	M20x1.5	27	11	32	15	15

FRONT ATTACHMENT Dimensions

	∅ a	∅ b	∅ c	∅ D1	∅ d2	g	∅ g1	k	p	p1
CLB 30	65	50	6.5	35	36	14	14	27	36	54
CLB 40	80	60	8.5	40	50	20	20	40	53	78

	q	r	s2	s3	t1	∅ t1	u	w	w1	w2	w3
CLB 30	9	32	19	14	36	18	21	65	81	28	16
CLB 40	10	42	25	18	42	25	27	90	115	40	25

Linear actuators CLA Series and CLB Series

3.5 OPTIONS AND ACCESSORIES

MOTOR MOUNTING SIDE – MAIN INPUT SIDE

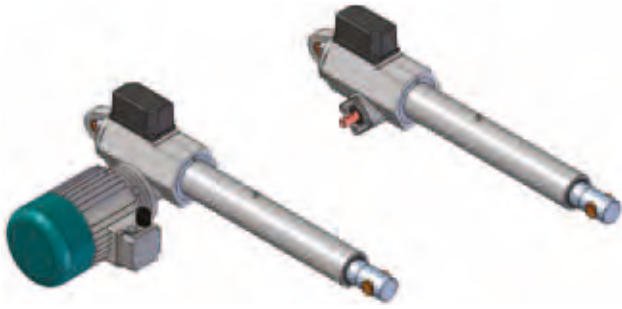

ON REQUEST: LEFT side
Code: LH

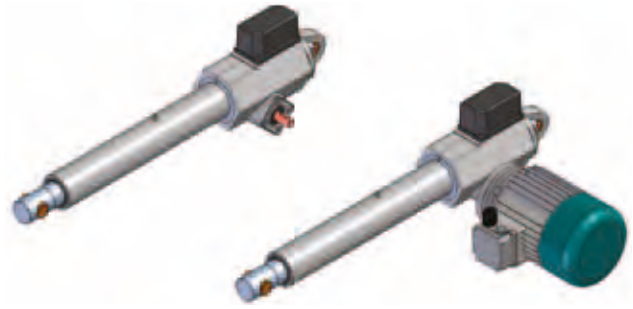

STANDARD: RIGHT side
Code: RH

ELECTRIC MOTOR TERMINAL BOX POSITION

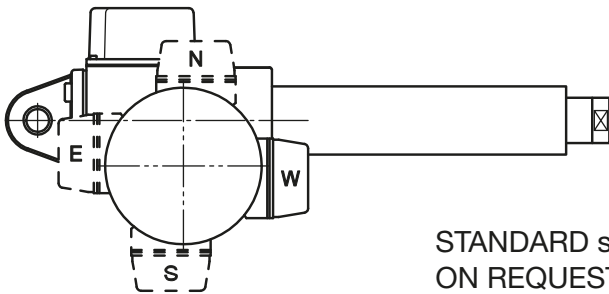

STANDARD side: W
ON REQUEST side: E ; N ; S

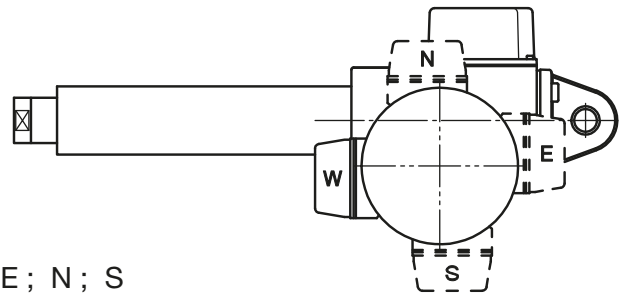

POSITION OF FRONT AND REAR ACTUATOR ATTACHMENT

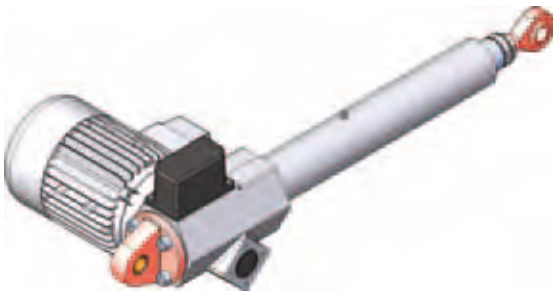

STANDARD

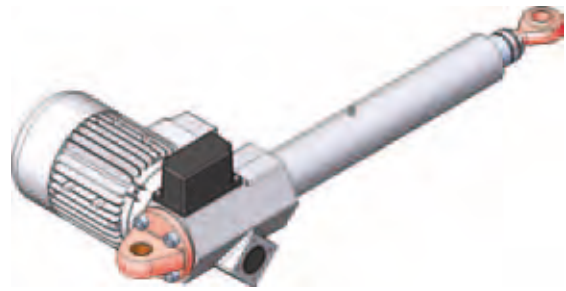

ON REQUEST: turned at 90°
Code: RPT 90°
NOTE: NOT available for size 50

INTERMEDIATE FLANGE Code FI

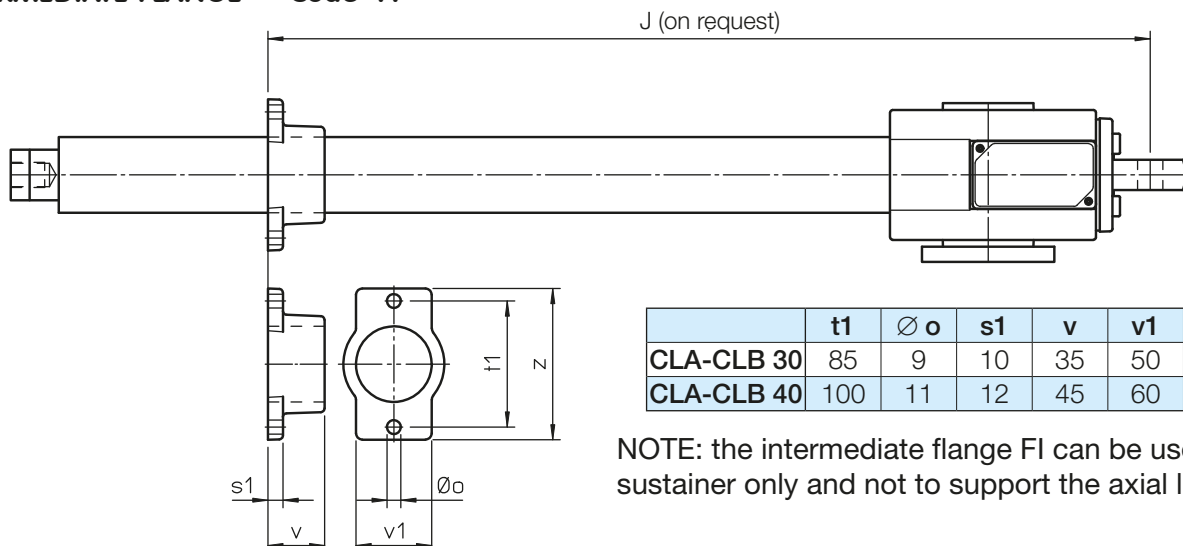

	t1	Ø o	s1	v	v1	z
CLA-CLB 30	85	9	10	35	50	100
CLA-CLB 40	100	11	12	45	60	120

NOTE: the intermediate flange FI can be used as sustainer only and not to support the axial load!

Linear actuators CLA Series and CLB Series

3.5 OPTIONS

ACTUATOR INPUT – size 30 - 40 - 50

Single input shaft

Code: **Vers.1**

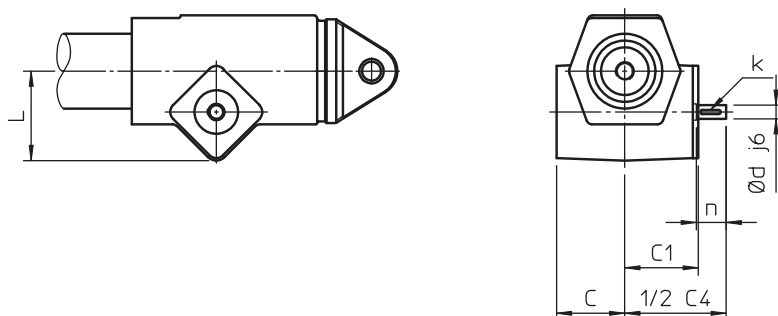

Double input shaft

Code: **Vers.2**

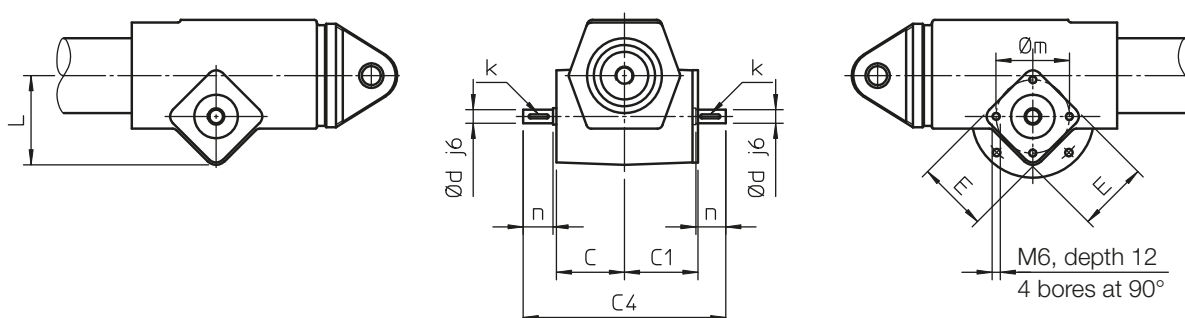

Attachment for IEC _ B14 electric motor (flange and hollow shaft)

Code: **Vers.3**

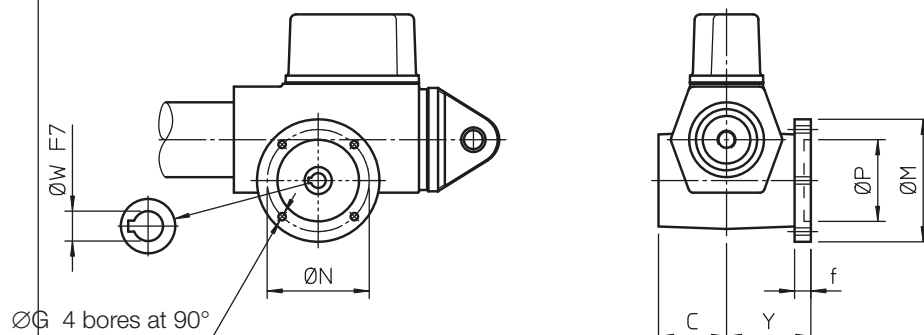

Attachment for IEC _ B14 electric motor (flange and hollow shaft) and second shaft

Code: **Vers.4**

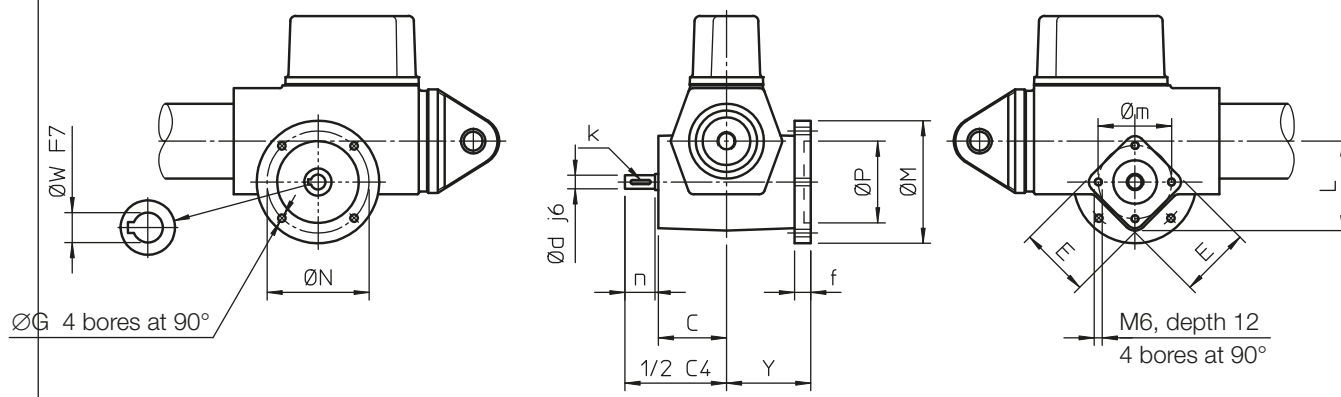

	C	C1	C4	E	L	k	Y	Ø d	Ø m	n	IEC motor	Ø G	Ø M	Ø N	Ø P	Ø W	f
CLA-CLB 30	50	54	149	52	66	3x3x15	62	10	54	22	63 B14	5.5	90	75	60	11	12
CLA-CLB 40	57	61	179	53	80	5x5x20	69	14	54	30	71 B14	6.5	105	85	70	14	12
CLA-CLB 50	57	61	179	53	80	5x5x20	69	14	54	30	71 B14	6.5	105	85	70	14	12

Linear actuators CLA Series and CLB Series

3.5 OPTIONS

ACTUATOR INPUT – size 50

CLA-CLB 50: attachment for IEC _ B14 electric motor (adapter and coupling)
Code: **Vers.5**

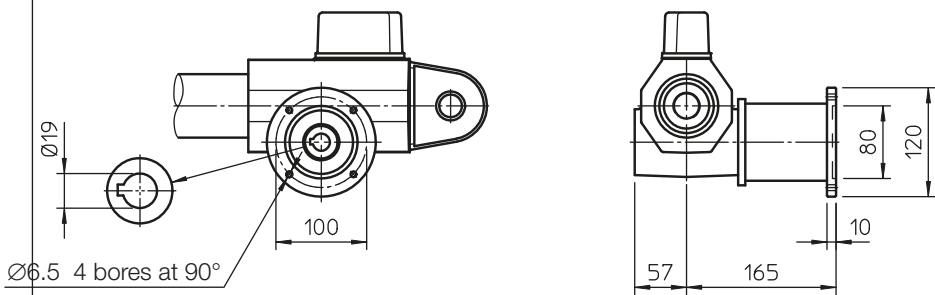

CLA-CLB 50: attachment for IEC _ B14 electric motor (adapter and coupling) and second shaft
Code: **Vers.6**

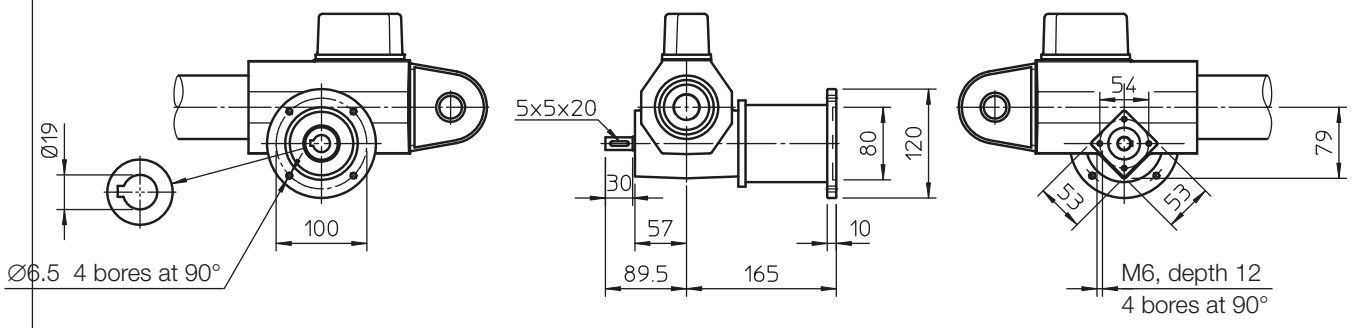

3

Linear actuators CLA Series and CLB Series

3.5 ACCESSORIES

ELECTRIC STROKE END SWITCHES Code FC

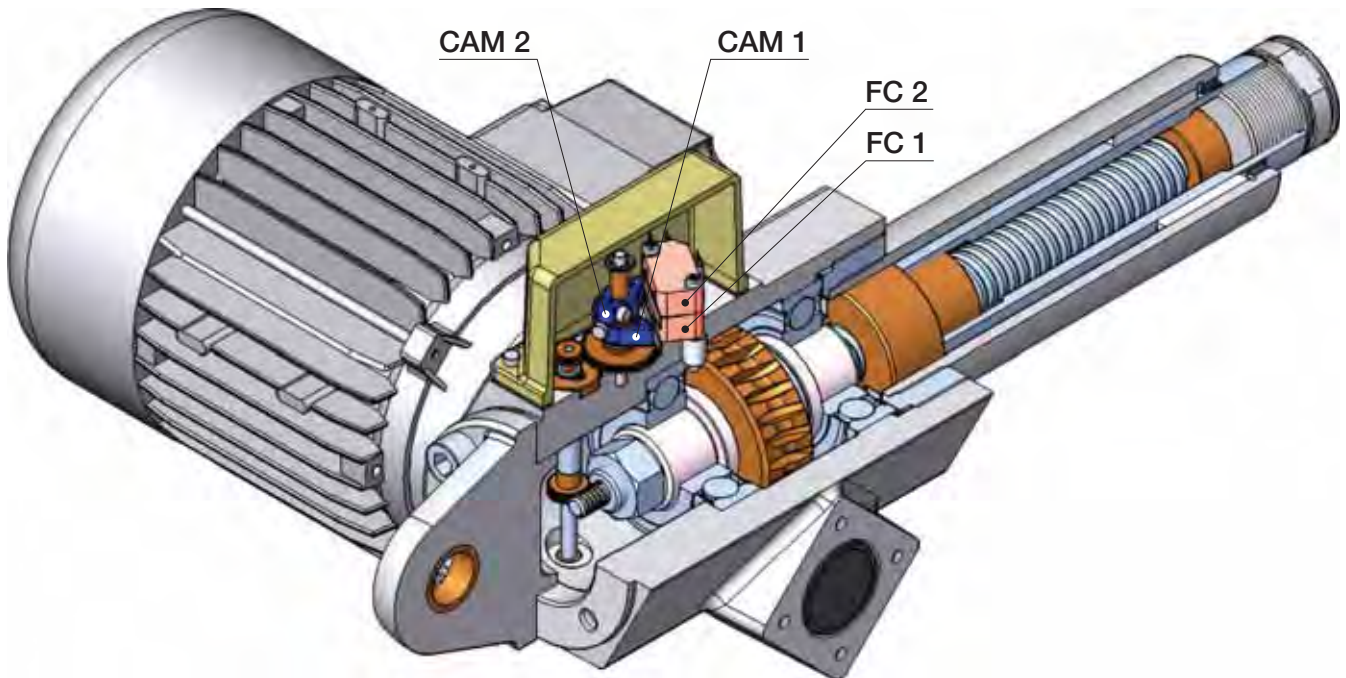

The ELECTRIC STROKE END SWITCHES allow to limit the actuator stroke avoiding to exceed the extreme positions (Lc or La) and reach the mechanical stops and in this way preventing possible damage.

The ELECTRIC STROKE END SWITCHES consists of two normally closed miniature electric switches that are fixed on the actuator housing and operated by cams.

The cams are driven by the acme or ball screw through a two-stage gear transmission. The first stage consists of a worm gear with constant ratio. The second stage consists of a cylindrical straight-tooth gear with ratio that depends on the maximum actuator stroke.

To set up the actual actuator working stroke, the rod shall be positioned in the required position (EXTENDED ACTUATOR or RETRACTED ACTUATOR) and set the position of the relevant cam around the support tube, turning and fixing it in the right position. **CAM 1** operates the switch **FC 1**, which corresponds to the RETRACTED ACTUATOR (Lc) stopping position, while **CAM 2** operates the switch **FC 2**, which corresponds to the EXTENDED ACTUATOR (La) stopping position.

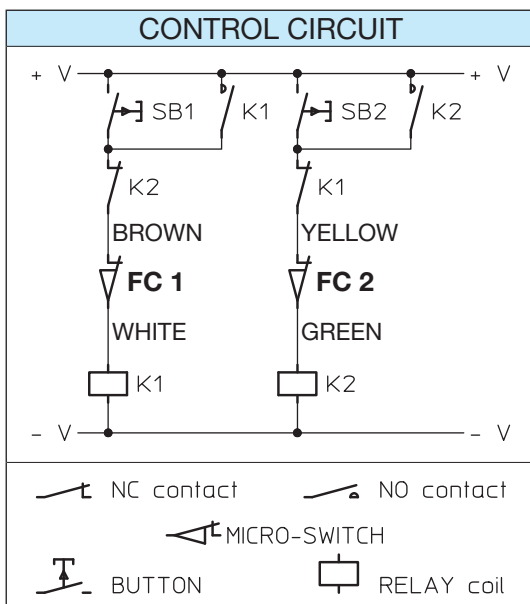

The entire assembly – switches, cams and cam driving transmission - is inside a sealed box.

The ELECTRIC STROKE END SWITCHES must be connected to the electric control circuit as shown in the WIRING DIAGRAM on the left to guarantee motor switch off and to prevent damage to the actuator and to the application equipment.

The ELECTRIC STROKE END SWITCHES are supplied already wired with a multicore cables 2 × 0.75 mm², standard length 1.5 m or longer cable on request. The wire colours are indicated in the diagram.

RATED CONTACT VALUES			
Voltage	250 V AC	125 V AC	125 V DC
Current (resistive load)	16 A	16 A	0.6 A
Current (inductive load)	10 A	10 A	0.6 A

Linear actuators CLA Series and CLB Series

3.5 ACCESSORIES

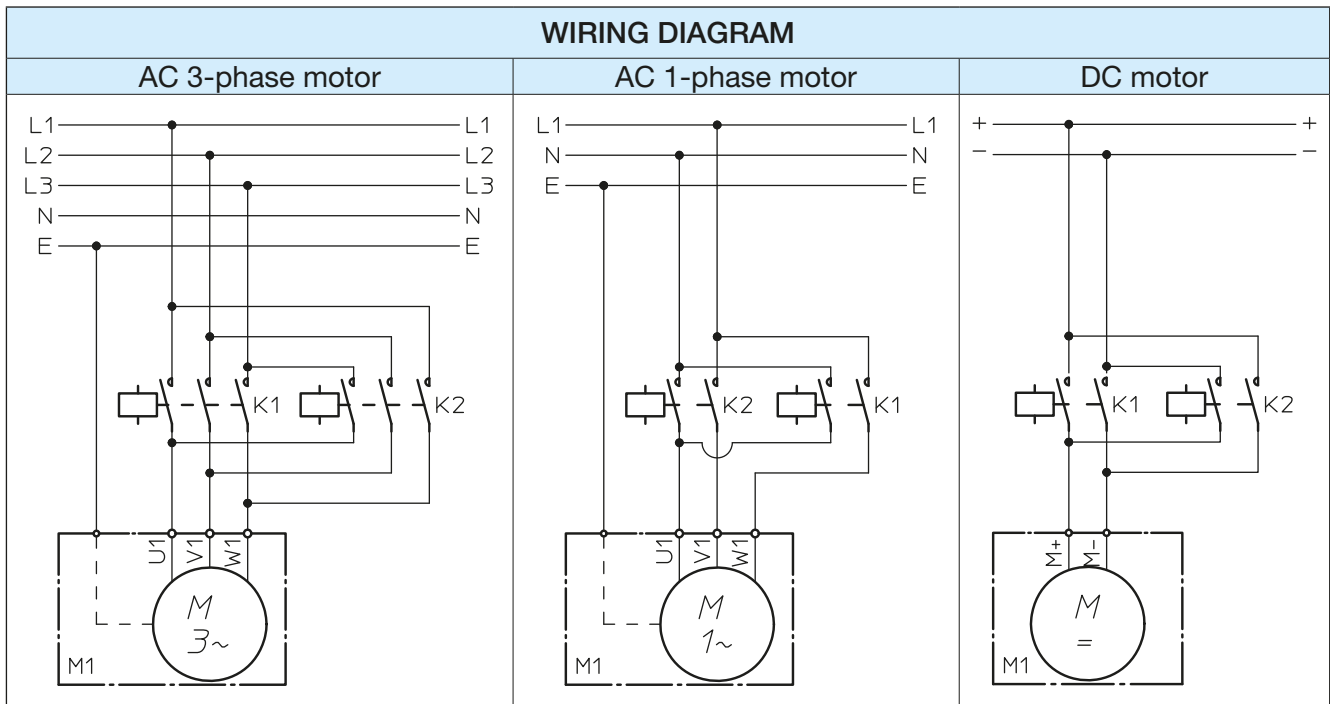

SWITCH FOR INTERMEDIATE POSITION Code FC 3

In case an electric signal is required to identify any intermediate position of the push rod (between Lc and La), in addition to the two switches **FC 1** and **FC 2** an extra switch **FC 3**, mounted above the first two and operated by the relevant **CAM 3**, can be supplied.

WARNING! The push rod position determined by the switch **FC 3** while the push rod is extending is different from the push rod position determined by the switch **FC 3** while the push rod is retracting. It is therefore necessary to verify the difference between the two positions, by direct check or asking **SERVOMECH**, to evaluate the compatibility with the application requirements.

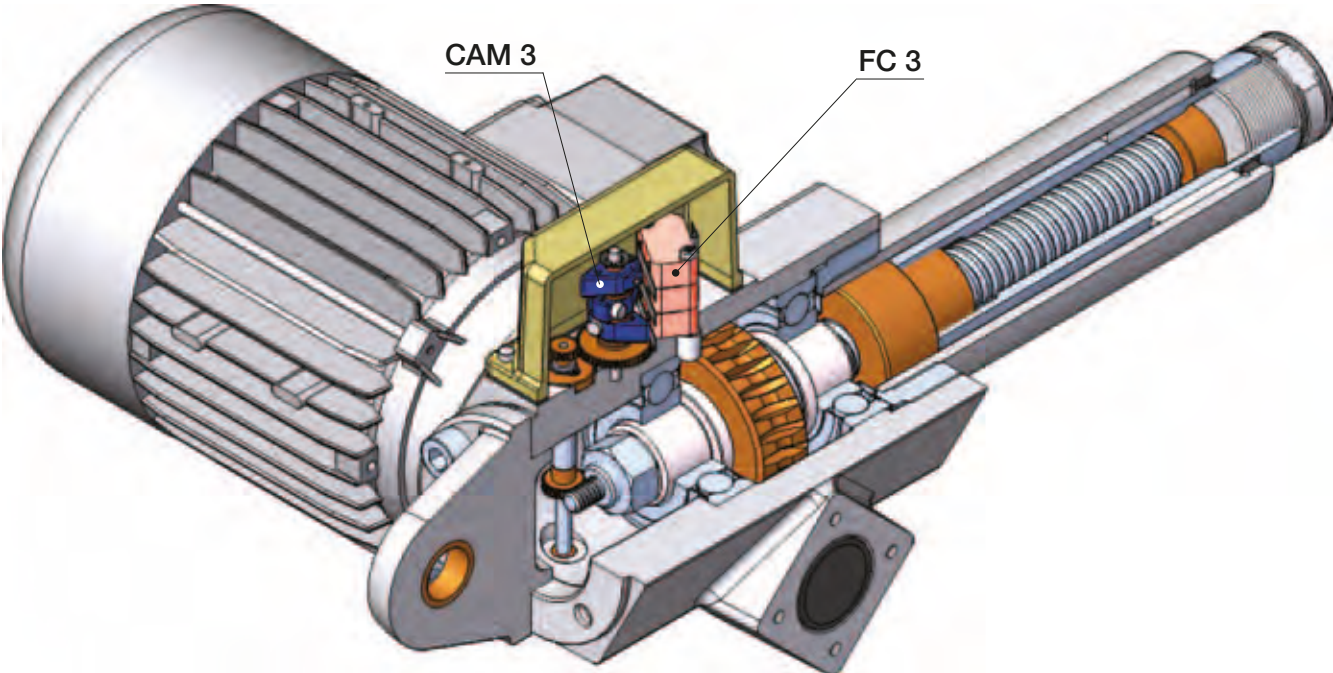

The switch **FC 3** is supplied with normally CLOSED contact already wired with a multicore cable $2 \times 0.75 \text{ mm}^2$, standard length 1.5 m or longer cable on request. The wire colours are BLUE and BROWN.

Linear actuators CLA Series and CLB Series

3.5 ACCESSORIES

ROTARY POTENTIOMETER Code POR 5k

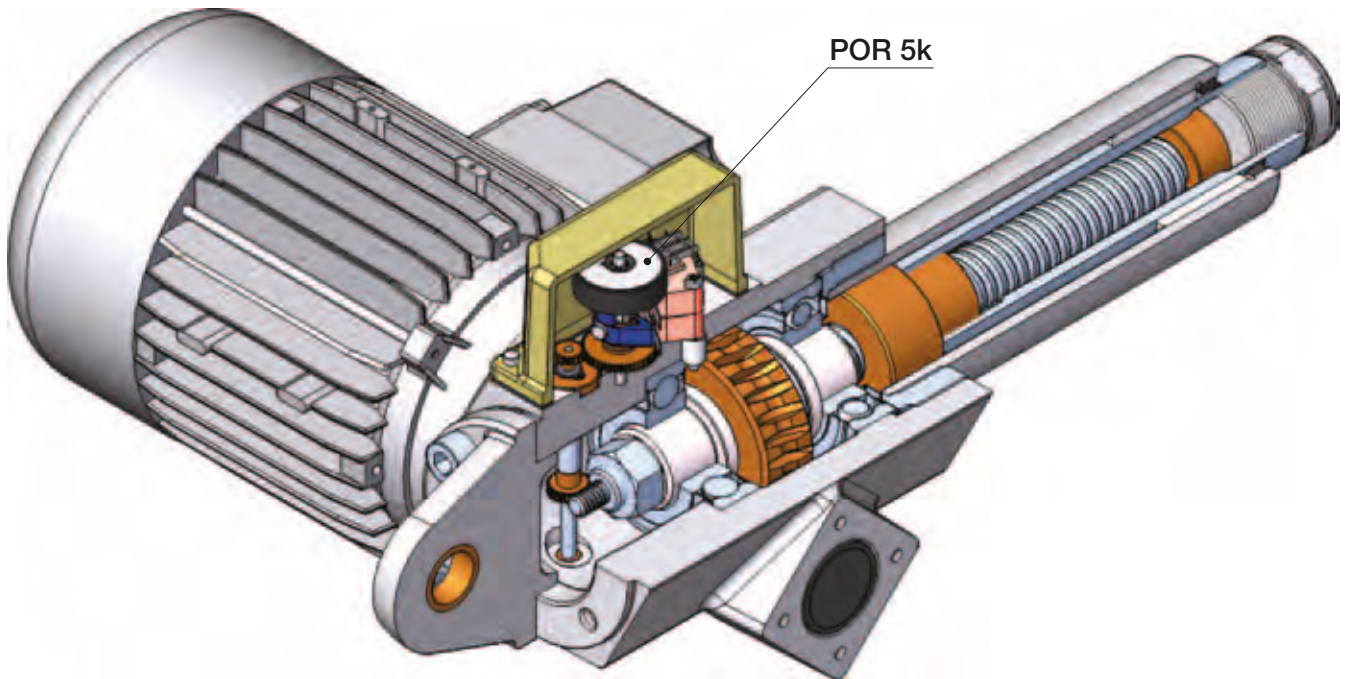

The ROTARY POTENTIOMETER is an absolute transducer whose output signal is proportional to the distance between the reference position (“ZERO” position) and the current position of the actuator push rod. The ROTARY POTENTIOMETER gives an analog output signal.

The ROTARY POTENTIOMETER is mounted on the same shaft that supports the cams which operate the stroke end switches and therefore it is driven by the same gear transmission. While the part of the potentiometer which contains the electric resistance remains stationary, because it is connected to the actuator housing through a reaction arm, the other part with the cursor inside is driven by the transmission shaft and rotates.

Electric features of the ROTARY POTENTIOMETER **POR 5k**:

- type: single-turn (340°)
- nominal resistance: 5 kΩ
- resistance tolerance: ± 20 %
- linearity: ± 2 %

Recommended wiring connection:

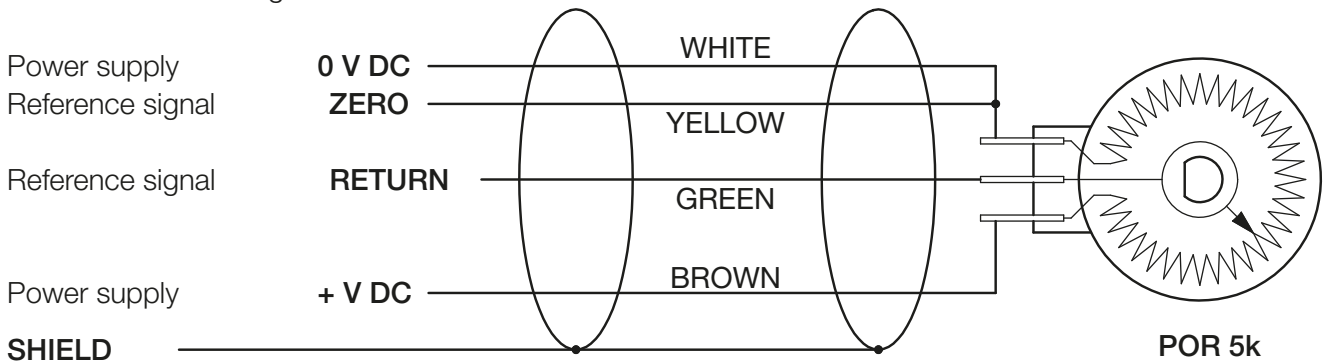

Multicore cable 4 × 0.25 mm² + shield, 1.5 m long

Linear actuators CLA Series and CLB Series

3.5 ACCESSORIES

ANTI-TURN device Code AR

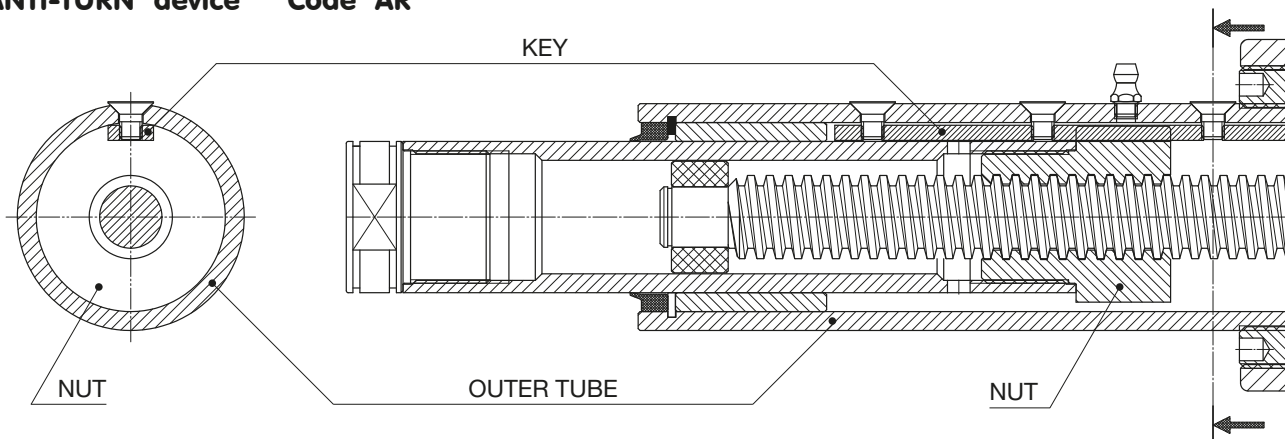

To achieve a linear motion it is necessary to prevent the rotary movement of the nut and of the push rod fixed to it. In many applications it is the external structure itself that, being connected to the push rod, prevents the rotation and allows the linear motion.

In some cases the load applied on the push rod cannot be guided and therefore the rotation cannot be avoided. In such cases it is necessary to use actuators with an internal anti-turn device. The ANTI-TURN device allows the linear motion without any external reaction on the push rod. It can be supplied upon request.

The anti-turn device shown in the above picture consists in a steel key fixed and aligned along the outer tube. The bronze nut, provided with a suitable keyway, slides on this key, making translate the push rod.

The ANTI-TURN DEVICE AR is available for acme screw linear actuators CLA Series only.

SAFETY CLUTCH Code FS

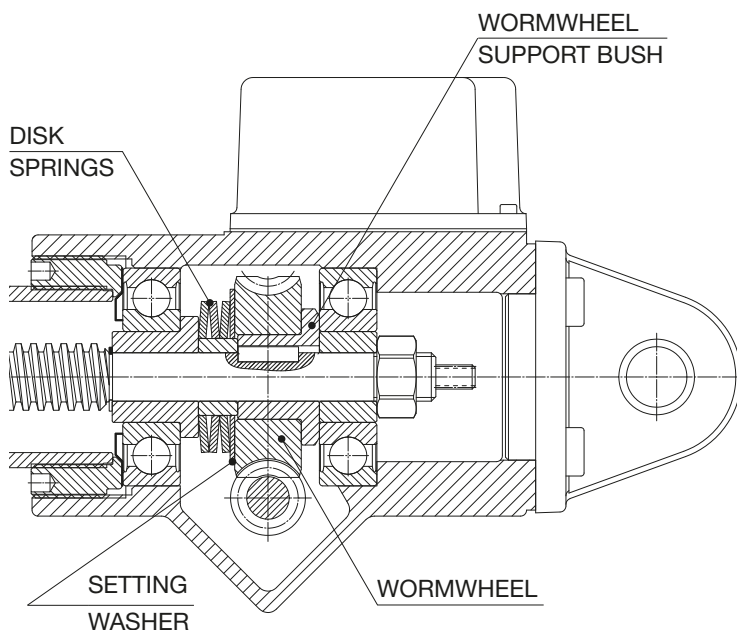

The SAFETY CLUTCH is a device able to protect the actuator and the machinery where it is installed from dynamic overload during the linear travel and from incorrect use which could bring the actuator to the mechanical stop. This device is a torque limiter on the worm wheel. The torque limiter clutch is preloaded during assembly. The preload is fixed and related to the ratio and the performances of each actuator as stated on the PERFORMANCE TABLES in this catalogue.

On request, with a purchasing order, a different preload can be set to achieve different performance.

If an overload is applied on the actuator, the SAFETY CLUTCH starts slipping and the push rod stops while the motor is still running.

When the overload decreases up to the rated load value or less, the SAFETY CLUTCH stops slipping and the push rod starts travelling again. The SAFETY CLUTCH FS is not intended to be used as a load limiter, but only to protect the actuator and the machinery where it is installed. Do not use the SAFETY CLUTCH as a stroke end control device! If it is frequently activated it rapidly wears, the preload is reduced and consequently also the actuator load performance is lower.

Linear actuators CLA Series and CLB Series

3.5 ACCESSORIES

SAFETY NUT Code MS

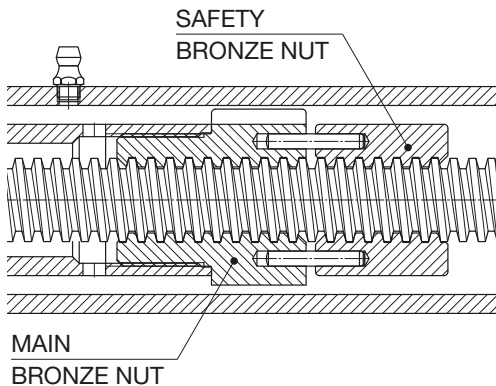

The SAFETY NUT is an auxiliary bronze nut connected by 2 pins to the main bronze nut. The distance between the two nuts in a new actuator is equal to a half of the thread pitch. If the main nut wears up to a half of the thread pitch or crashes, the SAFETY NUT supports the load avoiding its fall.

The SAFETY NUT is a one-direction device. Its position with respect to the main nut depends on the load direction. The SAFETY NUT is available for actuators working with push load. For applications with pull load a special design is available (contact SERVOMECH).

The SAFETY NUT MS is available for all acme screw actuators (CLA Series).

PROTECTIVE BELLOWS Code B

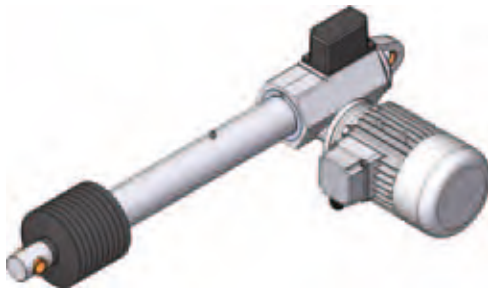

When the actuators are used in severe environment conditions with contaminant agents that can damage the seal scraper between the outer outer tube and the push rod, BELLOWS protection can be useful.

Bellows made of special materials for severe environments are available upon request.

3.6 SPECIAL DESIGNS

According to specific application requirements, special designs can be carried out on standard actuators.

Some possible options are for example:

- push rod in stainless steel AISI 304
- outer tube in stainless steel AISI 304
- lubricants for high or low ambient temperature
- lubricants suitable for food industry
- seals in VITON or silicone
- wiper seal on push rod with second lip in brass (ice scrapers)

Thanks to the long experience and know-how, SERVOMECH is able to support customers in selecting the right actuator version and accessories suitable for specific environment and installation conditions.

Linear actuators CLA Series and CLB Series

3.7 ORDERING CODE

CLA	40	RL1	C300	FO	—	FC+FC3	Vers. 3	RH
1	2	3	4	5	6	7	8.A	8.B

SP ...	9
--------	---

AC 3-phase motor	0.37 kW	4-pole	230/400 V	50 Hz	IP 55	Ins. F	W
			10.A				10.B

1	Actuator series CLA or CLB	
2	Actuator size 30, 40, 50	pages 104 ... 105
3	Ratio RV1, RN1, RL1, RXL1 RV2, RN2, RL2, RXL2	pages 104 ... 105
4	Stroke code (C...)	
5	Front attachment BA - standard head with threaded bore ROE - rod end FO - clevis end TS - ball joint FL - flange end TF - hinged head	pages 108 ... 113
6	Position of front and rear actuator attachment STANDARD (without code) or RPT 90°	page 114
7	Stroke end switches, Rotary potentiometer FC - electric stroke end switches FC + FC3 - electric stroke end switches + switch for intermediate position FC + POR 5k - electric stroke end switches + Rotary potentiometer 5 kOhm	page 117 page 118 page 119
8.A	Actuator input Vers.1 - single input shaft Vers.2 - double input shaft Vers.3 - attachment for IEC motor (flange and hollow shaft) Vers.4 - attachment for IEC motor (flange and hollow shaft) + second shaft Vers.5 - attachment for IEC motor (adapter and coupling) Vers.6 - attachment for IEC motor (adapter and coupling) + second shaft	pages 115 ... 116
8.B	Motor mounting side - main input drive side RH (standard) or LH	page 114
9	Accessories SP - rear bracket FI - intermediate support flange AR - anti-turn device FS - safety clutch MS - safety nut for push load B - bellows	pages 108 ... 113 page 114 page 120 page 120 page 121 page 121
10.A	Motor data	pages 200 ... 201
10.B	Motor terminal box position	page 114
11	Other specifications example: push rod in stainless steel AISI 303 example: lubricant for low temperature	
12	Filled in SELECTION DATA sheet	page 123
13	Application layout	

APPLICATION: _____

REQUIRED STROKE: _____ mm

REQUIRED LINEAR SPEED: _____ mm/s _____ mm/min _____ m/min TIME TO PERFORM 1 STROKE: _____ s

STATIC LOAD: PULL: _____ N PUSH: _____ N at STROKE _____ mm

DYNAMIC LOAD: PULL: _____ N PUSH: _____ N at STROKE _____ mm

ACTUATOR SUBJECTED TO VIBRATIONS NOT SUBJECTED TO VIBRATIONS

OPERATING: _____ cycle / hour _____ working hours / day Notes: _____

REQUIRED LIFETIME: _____ cycle _____ hours _____ calendar days Notes: _____

ENVIRONMENT: TEMPERATURE _____ °C DUST HUMIDITY _____ % AGGRESSIVE AGENT _____

Acme screw actuators **CLA Series** Ball screw actuators **CLB Series**

Size: 30 40 50

Ratio: RV2 RV1 RN2 RN1 RL2 RL1 RXL2 RXL1

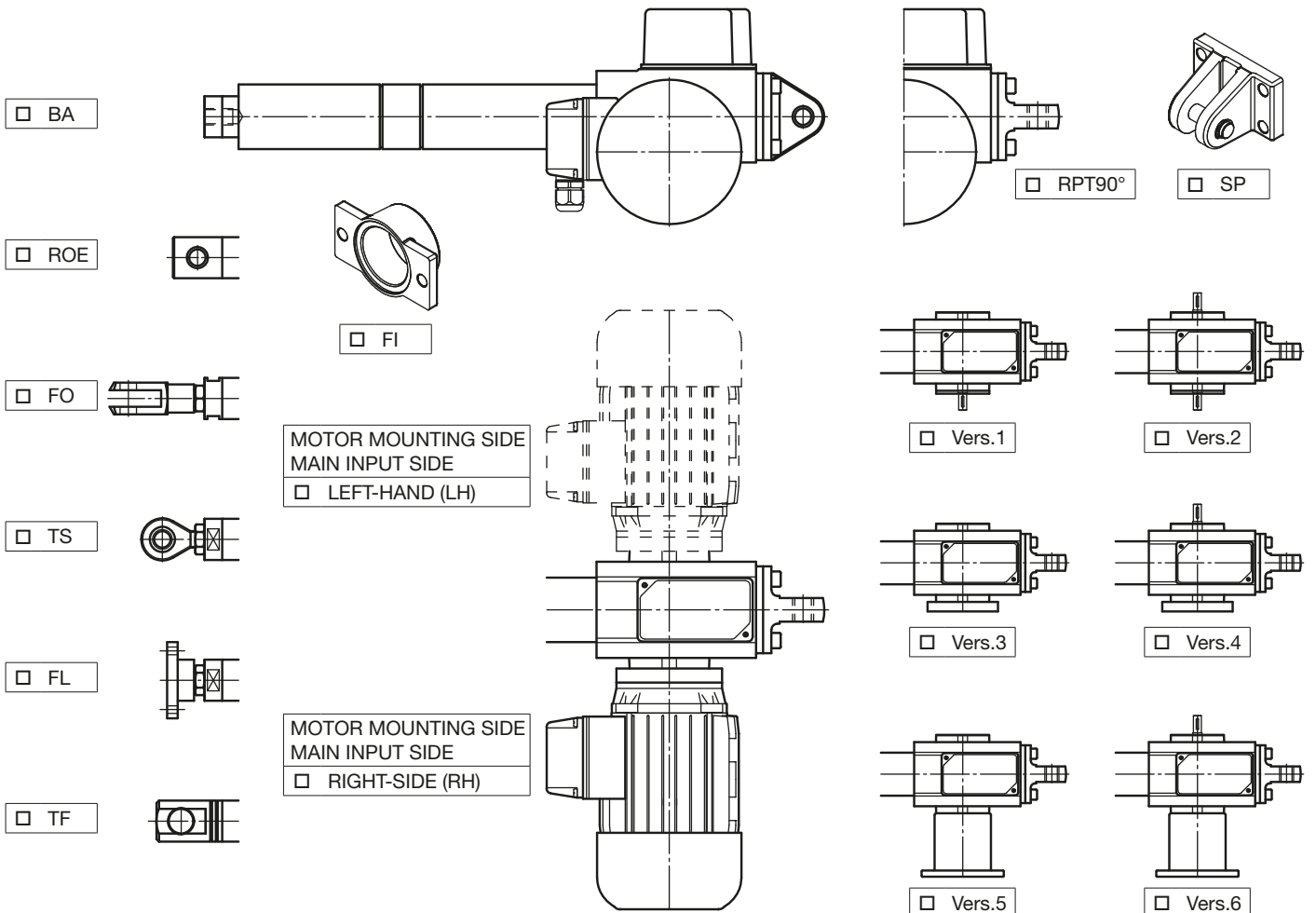

- ELECTRIC MOTOR AC 3-phase AC 1-phase DC 24 V or 12 V WITHOUT BRAKE WITH BRAKE
 ELECTRIC STROKE END SWITCHES FC SWITCH FOR INTERMEDIATE POSITION FC3 ROTARY POTENTIOMETER POR5k
 ANTI-TURN DEVICE AR SAFETY CLUTCH FS SAFETY NUT MS
 BELLOWS PUSH ROD IN STAINLESS STEEL OUTER TUBE IN STAINLESS STEEL

OTHER: _____

Acme screw actuators **CLA Series**

Ball screw actuators **CLB Series**

PRODUCT: _____

Product serial number: _____ ; q.ty: _____

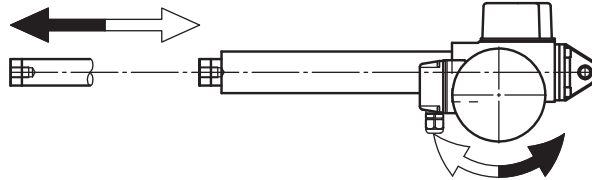

STANDARD HEAD

BA

LEFT-HAND MOUNTING

RIGHT-HAND MOUNTING

CLEVIS END

FO

ELECTRIC MOTOR

- AC 3-phase
- AC 1-phase
- DC

BALL JOINT

TS

- WITHOUT brake
- WITH brake

FLANGE END

FL

- internally powered
- separately powered

ROD END

ROE

Servomech. QMS

PASSED

Date: _____

Signature: _____

HINGED HEAD

TF

LINEAR ACTUATOR LENGTH (ref. to BA ROE TF FL)

WORKING RANGE

INTERNAL MECHANICAL STOP LIMIT

RETRACTED ACTUATOR length: $L_c =$ _____ mm

MIN. actuator length: _____ mm

EXTENDED ACTUATOR length: $L_a =$ _____ mm

MAX. actuator length: _____ mm

STROKE ($L_a - L_c$): $C =$ _____ mm

ELECTRIC STROKE END SWITCHES FC □

SWITCH FOR INTERMEDIATE POSITION FC 3 □

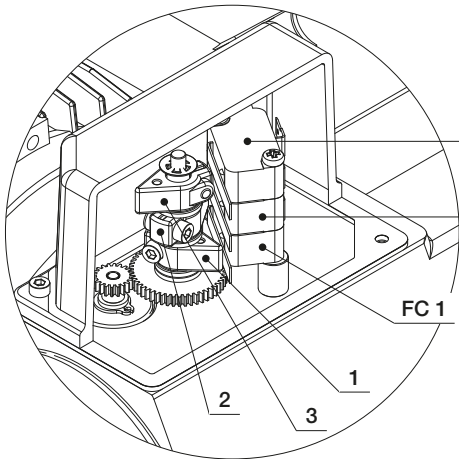

The ELECTRIC STROKE END SWITCHES **FC** has miniature switches FC 1 and FC 2. The switch FC 3 can determine any intermediate position between Lc and La.

- contact: **normally CLOSED**
- voltage: 250 V AC / 125 V AC / 125 V DC
- current: 16 A / 16 A / 0.6 A (resistive load)
10 A / 10 A / 0.6 A (inductive load)

The RETRACTED ACTUATOR position is set by the adjustable cam 1. The wires that connect the switch FC 1 are WHITE and BROWN.

The EXTENDED ACTUATOR position is set by the adjustable cam 2. The wires that connect the switch FC 2 are GREEN and YELLOW.

The INTERMEDIATE position is set by the adjustable cam 3. The wires that connect the switch FC 3 are BLUE and BROWN.

SINGLE SWITCH WIRING:

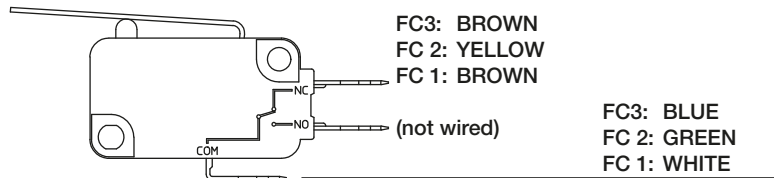

ROTARY POTENTIOMETER POR 5k □

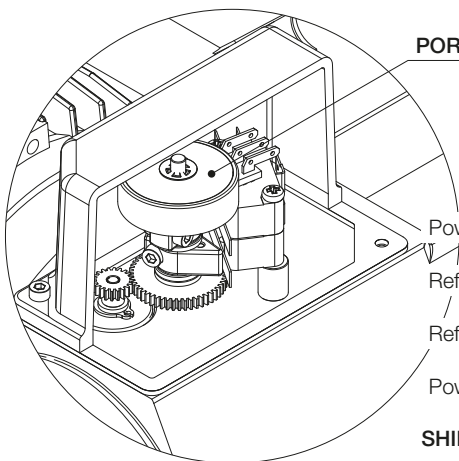

Technical features:

- type: single-turn (340°)
- nominal resistance: 5 kΩ
- resistance tolerance: ± 20 %
- linearity: ± 2 %

RECOMMENDED WIRING CONNECTION:

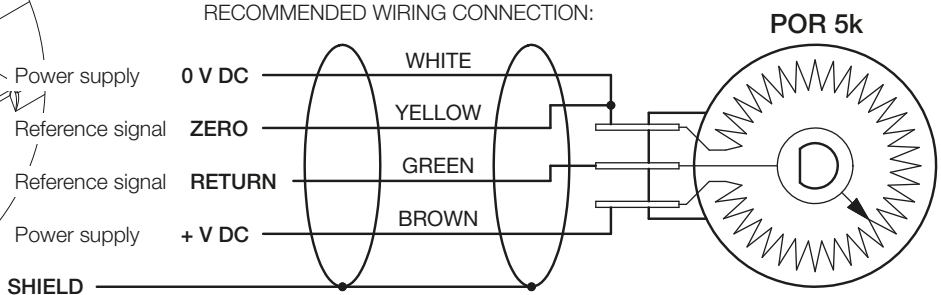

WARNING!

1. The values **Lc** (RETRACTED ACTUATOR length), **La** (EXTENDED ACTUATOR length) and **C** (STROKE) are the extreme limit values.
2. **BEFORE** using the linear actuator:
 - verify the input shaft rotating direction and the push rod running direction;
 - check the stroke end switches position: they must not exceed the extreme limit positions;
 - make sure that the motor and the limit switches are correctly connected and that the right voltage is used.
3. Linear actuators equipped with brake motor:
 - the brake is **NORMALLY CLOSED** (NEGATIVE action). When the power supply is switched off, the brake is engaged. The brake opens only when power is supplied;
 - if the brake is wired directly to the connecting pins of the terminal box, it does not require any power supply;
 - if the brake is wired separately, make sure that the correct voltage is used;
 - if the brake is equipped with hand release device, make sure that the brake is engaged before starting the linear actuator.
4. **Alignment check:** the load must be in line with the actuator. No off-set or radial loads are allowed.

NOTE: _____

WORMGEAR LUBRICANT: _____

SCREW – NUT LUBRICANT: _____

Linear actuators UBA Series and UAL Series

4

UBA - UAL Series, size 1 - 2 - 3 - 4

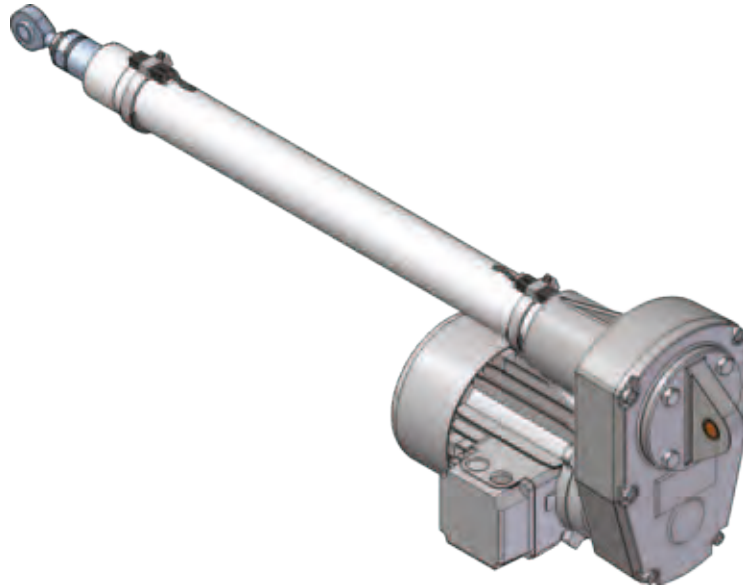

UBA - UAL Series, size 5

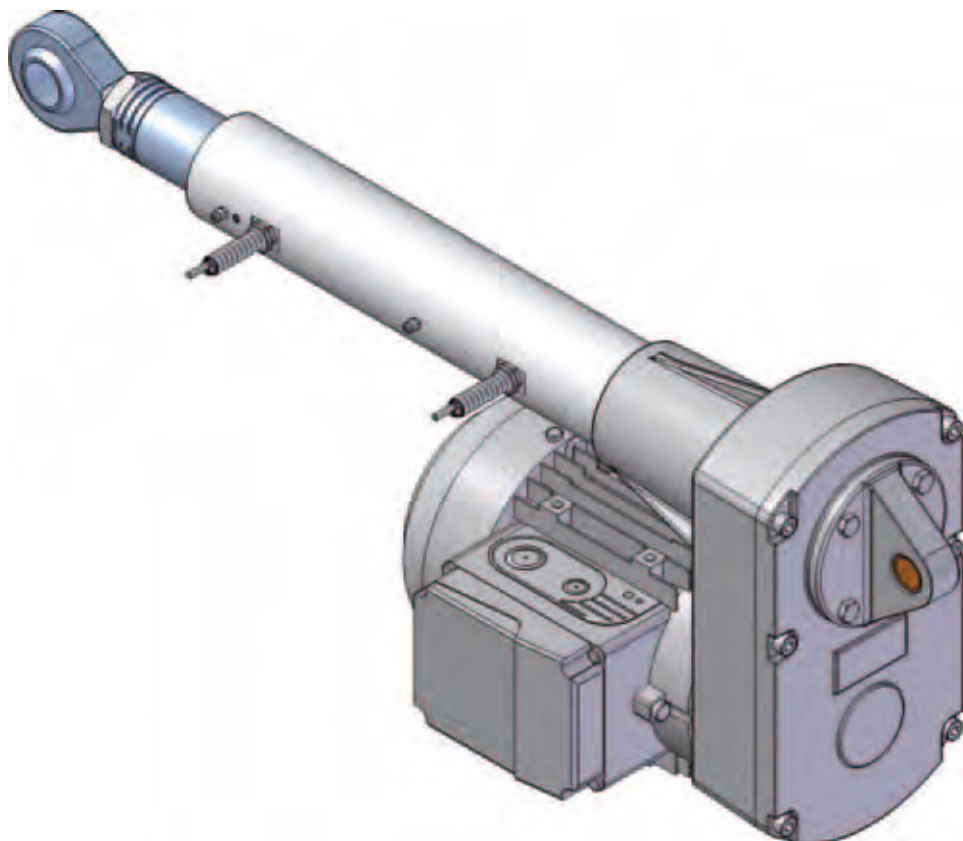

Linear actuators UBA Series and UAL Series

4.1 MANUFACTURING FEATURES

Input drive: timing belt transmission; pulleys UNI ISO 5294:1991 in aluminium for low inertia; positive timing belts UNI ISO 5296-1:1991.

Housing: designed and manufactured in monobloc form to obtain a compact body able to sustain heavy axial loads and high machining accuracy. High quality materials are used:

- castings in hardened aluminium alloy EN 1706 AC-AISI10Mg T6

Acme screw:

- ISO trapezoidal thread ISO 2901 ... ISO 2904
- material: steel C 43 (UNI 7847)
- rolled or whirled
- subjected to straightening, to ensure accurate alignment in operation
- max. pitch error ± 0.05 mm over 300 mm length

Bronze nut:

- ISO trapezoidal thread ISO 2901 ... ISO 2904
- material: bronze EN 1982 – CuAl9-C (1-start thread)
- material: bronze EN 1982 – CuSn12-C (multiple start thread)
- max. axial backlash for new nut (0.10 ... 0.12) mm

Outer tube:

- material: aluminium alloy EN AW-6060 thick cold-drawn tube anodized ARC 20 (UNI 4522/66) inner diameter tolerance ISO H9
- steel St 52.2 (DIN 2391) cold-drawn tube inner diameter tolerance ISO H10 ... H11

Bearings:

- on actuator axis: angular contact ball bearings, to avoid axial backlash and to assure high push-pull load capacity

Front attachment:

- standard – with threaded hollow bore, in stainless steel AISI 303 or steel C 43 (UNI 7847)

Rear bracket:

- in aluminium alloy for ATL-BSA 20, 25, 28, 30, 40
- pin in stainless steel AISI 303

Magnetic stroke end switches FCM:

- magnetic switches activated by a magnetic ring, for UAL-UBA 1, 2, 3, 4

Proximity stroke end switches FCP:

- proximity switches activated by the nut, for UAL-UBA 5

Ball screw:

- designed and manufactured by SERVOMECH
- rolled and hardened material: steel 42 CrMo 4 (UNI EN 10083) accuracy grade: ISO IT 7
- hardened and machined material: steel 42 CrMo 4 (UNI EN 10083) accuracy grade: ISO IT 5

Ball nut:

- designed and manufactured by SERVOMECH
- material: steel 18 NiCrMo 5 (UNI EN 10084), case hardened
- max. axial backlash (0.07 ... 0.08) mm
- on request, ball nut with ZERO backlash or pre-loaded using selected diameter balls

Push rod:

- material: steel St 52 (DIN 2391) thick tube chrome-plated, min. chrome thickness 5/100 mm inner diameter tolerance ISO f7
- push rod in stainless steel INOX AISI 304 or special stainless steel on request

Linear actuators UBA Series

4.2 TECHNICAL DATA - ball screw linear actuators UBA Series

SIZE		UBA 1	UBA 2	UBA 3	UBA 4	UBA 5	
Push rod diameter	[mm]	25	30	35	40	50	
Outer tube diameter	[mm]	36	45	55	60	70	
Attachment flange for IEC standard motor		56 B14	63 B14	71 B14	80 B14 90 B14	80 B14 90 B14	
Max. dynamic load.	[N]	1 800	3 400	3 900	5 700	10 850	
Max. static load	pull [N]	4 000	6 000	10 000	12 000	15 000	
	push [N]	4 000	6 000	10 000	12 000	15 000	
Ratio	RV	1 : 1.33 (18 : 24)	1 : 1.4 (20 : 28)	1 : 1.04 (24 : 25)	1 : 1.07 (30 : 32)	1 : 1.07 (30 : 32)	
	RN	1 : 2.15 (13 : 28)	1 : 2.13 (15 : 32)	1 : 2 (16 : 32)	1 : 1.94 (18 : 35)	1 : 1.94 (18 : 35)	
	RL	1 : 3 (10 : 30)	1 : 2.83 (12 : 34)	1 : 2.92 (12 : 35)	1 : 2.93 (15 : 44)	1 : 2.93 (15 : 44)	
Ball screw	Diameter × Lead	14×5	16×5	20×5	25×6	32×10	
	Ball [mm]	3.175 (1/8 ")	3.175 (1/8 ")	3.175 (1/8 ")	3.969 (5/32 ")	6.350 (1/4 ")	
	N° of circuits	2	3	3	3	4	
	Dynamic load C _a [N]	6 600	10 400	12 000	17 400	41 800	
	Static load C _{0a} [N]	8 600	15 600	21 200	30 500	73 000	
Linear travel [mm] for 1 input shaft revolution	Ratio	RV1	3.75	3.57	4.8	5.62	9.38
		RN1	2.32	2.34	2.5	3.09	5.14
		RL1	1.67	1.76	1.71	2.05	3.41
Ball screw	Diameter × Lead	14×10	16×10	20×10	25×10	32×20	
	Ball [mm]	3.175 (1/8 ")	3.175 (1/8 ")	3.175 (1/8 ")	3.969 (5/32 ")	6.350 (1/4 ")	
	N° of circuits	2	3	3	3	3	
	Dynamic load C _a [N]	6 900	11 300	12 900	18 000	32 200	
	Static load C _{0a} [N]	9 300	18 000	23 500	33 000	53 000	
Linear travel [mm] for 1 input shaft revolution	Ratio	RV2	7.5	7.14	9.6	9.38	18.75
		RN2	4.64	4.69	5	5.14	10.29
		RL2	3.33	3.53	3.43	3.41	6.82
Mass (actuator 100 mm stroke length, without motor, with lubricant)	[kg]	3.3	5	8	11	19	
Extra-mass for each additional 100 mm stroke length	[kg]	0.3	0.5	0.8	0.9	2	

Linear actuators UAL Series

4.2 TECHNICAL DATA - acme screw linear actuators UAL Series

SIZE		UAL 1	UAL 2	UAL 3	UAL 4	UAL 5	
Push rod diameter	[mm]	25	30	35	40	50	
Outer tube diameter	[mm]	36	45	55	60	70	
Attachment flange for IEC standard motor		56 B14	63 B14	71 B14	80 B14 90 B14	80 B14 90 B14	
Max. dynamic load	[N]	1 600	2 500	5 100	8 700	10 400	
Max. static load	pull [N]	4 000	6 000	10 000	12 000	15 000	
	push [N]	4 000	6 000	10 000	12 000	15 000	
Ratio	RV	1 : 1.33 (18 : 24)	1 : 1.4 (20 : 28)	1 : 1.04 (24 : 25)	1 : 1.07 (30 : 32)	1 : 1.07 (30 : 32)	
	RN	1 : 2.15 (13 : 28)	1 : 2.13 (15 : 32)	1 : 2 (16 : 32)	1 : 1.94 (18 : 35)	1 : 1.94 (18 : 35)	
	RL	1 : 3 (10 : 30)	1 : 2.83 (12 : 34)	1 : 2.92 (12 : 35)	1 : 2.93 (15 : 44)	1 : 2.93 (15 : 44)	
1-start acme screw		Tr 13.5×3	Tr 16×4	Tr 18×4	Tr 22×5	Tr 30×6	
Linear travel [mm] for 1 input shaft revolution	Ratio	RV1	2.25	2.86	3.84	4.69	5.63
		RN1	1.39	1.88	2	2.57	3.09
		RL1	1	1.41	1.37	1.70	2.05
2-start acme screw		Tr 14×8 (P4)	Tr 16×8 (P4)	Tr 18×8 (P4)	Tr 22×10 (P5)	Tr 30×12 (P6)	
Linear travel [mm] for 1 input shaft revolution	Ratio	RV2	6	5.71	7.68	9.38	11.25
		RN2	3.71	3.75	4	5.14	6.17
		RL2	2.67	2.82	2.74	3.41	4.09
Mass (actuator 100 mm stroke length, without motor, with lubricant)		[kg]	3.3	5	8	11	18
Extra-mass for each additional 100 mm stroke length		[kg]	0.3	0.5	0.8	0.9	2

Linear actuators UBA Series

BALL SCREW LINEAR ACTUATORS UBA Series with AC 3-PHASE MOTOR
PERFORMANCE with: Duty Cycle $F_i = 100\%$ at ambient temperature $25\text{ }^\circ\text{C}$

LINEAR SPEED [mm/s]	DYNAMIC LOAD [N]	RATIO	MOTOR: POWER [kW] – N° of POLES SPEED [rpm]	SELF-LOCKING COEFFICIENT
UBA 1				
350	290 ¹⁾	RV2	0.12 kW 2-pole 2800	0.72
215	460 ¹⁾	RN2	0.12 kW 2-pole 2800	0.72
175	570 ¹⁾	RV1	0.12 kW 2-pole 2800	0.72
155	650 ¹⁾	RL2	0.12 kW 2-pole 2800	0.72
105	950 ¹⁾	RN1	0.12 kW 2-pole 2800	0.72
85	800 ¹⁾	RV1	0.09 kW 4-pole 1400	0.72
75	1300 ¹⁾	RL1	0.12 kW 2-pole 2800	0.72
55	1300 ¹⁾	RN1	0.09 kW 4-pole 1400	0.72
40	1800 ³⁾	RL1	0.09 kW 4-pole 1400	0.72
UBA 2				
330	600 ¹⁾	RV2	0.25 kW 2-pole 2800	0.71
220	900 ¹⁾	RN2	0.25 kW 2-pole 2800	0.71
165	1200 ¹⁾	RL2	0.25 kW 2-pole 2800	0.71
110	1850 ¹⁾	RN1	0.25 kW 2-pole 2800	0.71
80	2450 ¹⁾	RL1	0.25 kW 2-pole 2800	0.71
55	2550 ¹⁾	RN1	0.18 kW 4-pole 1400	0.71
40	3400 ³⁾	RL1	0.18 kW 4-pole 1400	0.71
UBA 3				
450	960 ¹⁾	RV2	0.55 kW 2-pole 2800	0.70
235	1850 ¹⁾	RN2	0.55 kW 2-pole 2800	0.70
160	2700 ¹⁾	RL2	0.55 kW 2-pole 2800	0.70
115	2750 ²⁾	RN1	0.55 kW 2-pole 2800	0.70
80	3550 ¹⁾	RL2	0.37 kW 4-pole 1400	0.70
60	3450 ²⁾	RN1	0.37 kW 4-pole 1400	0.70
40	3900 ²⁾	RL1	0.37 kW 4-pole 1400	0.70
UBA 4				
440	1950 ¹⁾	RV2	1.1 kW 2-pole 2800	0.70
240	3550 ¹⁾	RN2	1.1 kW 2-pole 2800	0.70
160	4700 ²⁾	RL2	1.1 kW 2-pole 2800	0.70
120	4800 ¹⁾	RN2	0.75 kW 4-pole 1400	0.70
96	4500 ²⁾	RL1	1.1 kW 2-pole 2800	0.70
80	5900 ²⁾	RL2	0.75 kW 4-pole 1400	0.70
48	5700 ²⁾	RL1	0.75 kW 4-pole 1400	0.70
UBA 5				
875	1300 ¹⁾	RV2	1.5 kW 2-pole 2800	0.70
480	2400 ¹⁾	RN2	1.5 kW 2-pole 2800	0.70
440	2650 ¹⁾	RV1	1.5 kW 2-pole 2800	0.70
320	3650 ¹⁾	RL2	1.5 kW 2-pole 2800	0.70
240	4800 ¹⁾	RN1	1.5 kW 2-pole 2800	0.70
160	7250 ¹⁾	RL1	1.5 kW 2-pole 2800	0.70
120	7050 ¹⁾	RN1	1.1 kW 4-pole 1400	0.70
80	10650 ¹⁾	RL1	1.1 kW 4-pole 1400	0.70

¹⁾ value limited by electric motor power; ball screw lifetime $L_{10h} > 1000$ hours (see diagrams on pages 33 ... 35)

The total dynamic efficiency (η) of UBA Series actuators, used to determine the DYNAMIC LOAD is calculated as follows:

$$\eta = \eta_1 \times \eta_2 \times \eta_3$$

where:

$\eta_1 = 0.95$ – timing belt transmission efficiency

$\eta_2 = 0.9$ – ball screw - nut efficiency

$\eta_3 = 0.9$ – bearings and sealing elements "efficiency"

²⁾ value related to the ball screw lifetime $L_{10h} = 1000$ h, with constant load, without load vibrations nor shocks; for different lifetime refer to diagrams on pages 33 ... 35

³⁾ limit value of linear actuator dynamic load capacity (see page 128)

Linear actuators UAL Series

ACME SCREW LINEAR ACTUATORS UAL Series with AC 3-PHASE MOTOR
PERFORMANCE with: Duty Cycle $F_i = 30\%$ over 10 min at ambient temperature $25\text{ }^\circ\text{C}$

LINEAR SPEED [mm/s]	DYNAMIC LOAD [N]	RATIO	MOTOR: POWER [kW] – N° of POLES SPEED [rpm]	SELF-LOCKING COEFFICIENT
UAL 1				
280	300 ¹⁾	RV2	0.12 kW 2-pole 2800	0.51
170	450 ¹⁾	RN2	0.12 kW 2-pole 2800	0.51
120	600 ¹⁾	RL2	0.12 kW 2-pole 2800	0.51
105	600 ¹⁾	RV1	0.12 kW 2-pole 2800	0.32
85	600 ¹⁾	RN2	0.09 kW 4-pole 1400	0.51
60	860 ¹⁾	RL2	0.09 kW 4-pole 1400	0.51
50	800 ¹⁾	RV1	0.09 kW 4-pole 1400	0.32
45	1200 ¹⁾	RL1	0.12 kW 2-pole 2800	0.32
32	1200 ¹⁾	RN1	0.09 kW 4-pole 1400	0.32
23	1600 ²⁾	RL1	0.09 kW 4-pole 1400	0.32
UAL 2				
265	650 ¹⁾	RV2	0.25 kW 2-pole 2800	0.48
175	950 ¹⁾	RN2	0.25 kW 2-pole 2800	0.48
130	1200 ¹⁾	RL2	0.25 kW 2-pole 2800	0.48
87	1300 ¹⁾	RN2	0.18 kW 4-pole 1400	0.48
65	1950 ¹⁾	RL1	0.25 kW 2-pole 2800	0.35
43	2000 ¹⁾	RN1	0.18 kW 4-pole 1400	0.35
32	2500 ²⁾	RL1	0.18 kW 4-pole 1400	0.35
UAL 3				
360	1000 ¹⁾	RV2	0.55 kW 2-pole 2800	0.46
180	1850 ¹⁾	RN2	0.55 kW 2-pole 2800	0.46
130	2600 ¹⁾	RL2	0.55 kW 2-pole 2800	0.46
90	3000 ¹⁾	RN1	0.55 kW 2-pole 2800	0.32
64	4100 ¹⁾	RL1	0.55 kW 2-pole 2800	0.32
46	3650 ¹⁾	RN1	0.37 kW 4-pole 1400	0.32
32	5100 ²⁾	RL1	0.37 kW 4-pole 1400	0.32
UAL 4				
440	1700 ¹⁾	RV2	1.1 kW 2-pole 2800	0.46
240	3000 ¹⁾	RN2	1.1 kW 2-pole 2800	0.46
160	4300 ¹⁾	RL2	1.1 kW 2-pole 2800	0.46
120	5000 ¹⁾	RN1	1.1 kW 2-pole 2800	0.32
80	7000 ¹⁾	RL1	1.1 kW 2-pole 2800	0.32
60	6200 ¹⁾	RN1	0.75 kW 4-pole 1400	0.32
40	8700 ²⁾	RL1	0.75 kW 4-pole 1400	0.32
UAL 5				
529	2000 ¹⁾	RV2	1.5 kW 2-pole 2800	0.44
292	3350 ¹⁾	RN2	1.5 kW 2-pole 2800	0.44
265	3350 ¹⁾	RV1	1.5 kW 2-pole 2800	0.30
193	4800 ¹⁾	RL2	1.5 kW 2-pole 2800	0.44
146	5500 ¹⁾	RN1	1.5 kW 2-pole 2800	0.30
97	7800 ¹⁾	RL1	1.5 kW 2-pole 2800	0.30
72	7300 ¹⁾	RN1	1.1 kW 4-pole 1400	0.30
48	10400 ²⁾	RL1	1.1 kW 4-pole 1400	0.30

1) value limited by electric motor power

The total dynamic efficiency (η) of UAL Series actuators, used to determine the DYNAMIC LOAD is calculated as follows:

$$\eta = \eta_1 \times \eta_2 \times \eta_3$$

where:

$\eta_1 = 0.95$ – timing belt transmission efficiency

η_2 – acme screw-bronze nut dynamic efficiency, calculated with reference to the speed

$\eta_3 = 0.9$ – bearings and sealing elements "efficiency"

2) limit value of linear actuator dynamic load capacity (see page 129)

Linear actuators UBA Series

BALL SCREW LINEAR ACTUATORS UBA Series with AC 1-PHASE MOTOR
PERFORMANCE with: Duty Cycle $F_i = 100\%$ at ambient temperature $25\text{ }^\circ\text{C}$

LINEAR SPEED [mm/s]	DYNAMIC LOAD [N]	RATIO	MOTOR: POWER [kW] – N° of POLES SPEED [rpm]	SELF-LOCKING COEFFICIENT
UBA 1				
350	250 ¹⁾	RV2	0.12 kW 2-pole 2800	0.72
215	400 ¹⁾	RN2	0.12 kW 2-pole 2800	0.72
175	500 ¹⁾	RV1	0.12 kW 2-pole 2800	0.72
155	600 ¹⁾	RL2	0.12 kW 2-pole 2800	0.72
105	850 ¹⁾	RN1	0.12 kW 2-pole 2800	0.72
85	750 ¹⁾	RV1	0.09 kW 4-pole 1400	0.72
75	1200 ¹⁾	RL1	0.12 kW 2-pole 2800	0.72
55	1300 ¹⁾	RN1	0.09 kW 4-pole 1400	0.72
40	1800 ³⁾	RL1	0.09 kW 4-pole 1400	0.72
UBA 2				
330	550 ¹⁾	RV2	0.25 kW 2-pole 2800	0.71
220	850 ¹⁾	RN2	0.25 kW 2-pole 2800	0.71
165	1100 ¹⁾	RL2	0.25 kW 2-pole 2800	0.71
110	1650 ¹⁾	RN1	0.25 kW 2-pole 2800	0.71
80	2300 ¹⁾	RL1	0.25 kW 2-pole 2800	0.71
55	2550 ¹⁾	RN1	0.18 kW 4-pole 1400	0.71
40	3400 ³⁾	RL1	0.18 kW 4-pole 1400	0.71
UBA 3				
450	960 ¹⁾	RV2	0.55 kW 2-pole 2800	0.70
235	1850 ¹⁾	RN2	0.55 kW 2-pole 2800	0.70
160	2700 ¹⁾	RL2	0.55 kW 2-pole 2800	0.70
115	2750 ²⁾	RN1	0.55 kW 2-pole 2800	0.70
80	3550 ¹⁾	RL2	0.37 kW 4-pole 1400	0.70
60	3450 ²⁾	RN1	0.37 kW 4-pole 1400	0.70
40	3900 ²⁾	RL1	0.37 kW 4-pole 1400	0.70
UBA 4				
440	1900 ¹⁾	RV2	1.1 kW 2-pole 2800	0.70
240	3500 ¹⁾	RN2	1.1 kW 2-pole 2800	0.70
160	4700 ²⁾	RL2	1.1 kW 2-pole 2800	0.70
120	4800 ¹⁾	RN2	0.75 kW 4-pole 1400	0.70
96	4500 ²⁾	RL1	1.1 kW 2-pole 2800	0.70
80	5900 ²⁾	RL2	0.75 kW 4-pole 1400	0.70
48	5700 ²⁾	RL1	0.75 kW 4-pole 1400	0.70

¹⁾ value limited by electric motor power; ball screw lifetime $L_{10h} > 1000$ hours (see diagrams on pages 33 ... 35)

The total dynamic efficiency (η) of UBA Series actuators, used to determine the DYNAMIC LOAD is calculated as follows:

$$\eta = \eta_1 \times \eta_2 \times \eta_3$$

where:

$\eta_1 = 0.95$ – timing belt transmission efficiency

$\eta_2 = 0.9$ – ball screw - nut efficiency

$\eta_3 = 0.9$ – bearings and sealing elements "efficiency"

²⁾ value related to the ball screw lifetime $L_{10h} = 1000$ h, with constant load, without load vibrations nor shocks; for different lifetime refer to diagrams on pages 33 ... 35

³⁾ limit value of linear actuator dynamic load capacity (see page 128)

Linear actuators UAL Series

ACME SCREW LINEAR ACTUATORS UAL Series with AC 1-PHASE MOTOR
PERFORMANCE with: Duty Cycle $F_i = 30\%$ over 10 min at ambient temperature 25 °C

LINEAR SPEED [mm/s]	DYNAMIC LOAD [N]	RATIO	MOTOR: POWER [kW] – N° of POLES SPEED [rpm]	SELF-LOCKING COEFFICIENT
UAL 1				
280	300 ¹⁾	RV2	0.12 kW 2-pole 2800	0.51
170	450 ¹⁾	RN2	0.12 kW 2-pole 2800	0.51
120	600 ¹⁾	RL2	0.12 kW 2-pole 2800	0.51
105	600 ¹⁾	RV1	0.12 kW 2-pole 2800	0.32
85	600 ¹⁾	RN2	0.09 kW 4-pole 1400	0.51
60	860 ¹⁾	RL2	0.09 kW 4-pole 1400	0.51
50	800 ¹⁾	RV1	0.09 kW 4-pole 1400	0.32
45	1200 ¹⁾	RL1	0.12 kW 2-pole 2800	0.32
32	1200 ¹⁾	RN1	0.09 kW 4-pole 1400	0.32
23	1600 ²⁾	RL1	0.09 kW 4-pole 1400	0.32
UAL 2				
265	600 ¹⁾	RV2	0.25 kW 2-pole 2800	0.48
175	850 ¹⁾	RN2	0.25 kW 2-pole 2800	0.48
130	1100 ¹⁾	RL2	0.25 kW 2-pole 2800	0.48
87	1200 ¹⁾	RN2	0.18 kW 4-pole 1400	0.48
65	1800 ¹⁾	RL1	0.25 kW 2-pole 2800	0.35
43	2000 ¹⁾	RN1	0.18 kW 4-pole 1400	0.35
32	2500 ²⁾	RL1	0.18 kW 4-pole 1400	0.35
UAL 3				
360	900 ¹⁾	RV2	0.55 kW 2-pole 2800	0.46
180	1650 ¹⁾	RN2	0.55 kW 2-pole 2800	0.46
130	2350 ¹⁾	RL2	0.55 kW 2-pole 2800	0.46
90	2700 ¹⁾	RN1	0.55 kW 2-pole 2800	0.32
64	3700 ¹⁾	RL1	0.55 kW 2-pole 2800	0.32
46	3300 ¹⁾	RN1	0.37 kW 4-pole 1400	0.32
32	4600 ¹⁾	RL1	0.37 kW 4-pole 1400	0.32
UAL 4				
440	1550 ¹⁾	RV2	1.1 kW 2-pole 2800	0.46
240	2700 ¹⁾	RN2	1.1 kW 2-pole 2800	0.46
160	3900 ¹⁾	RL2	1.1 kW 2-pole 2800	0.46
120	4500 ¹⁾	RN1	1.1 kW 2-pole 2800	0.32
80	6300 ¹⁾	RL1	1.1 kW 2-pole 2800	0.32
60	5600 ¹⁾	RN1	0.75 kW 4-pole 1400	0.32
40	7900 ¹⁾	RL1	0.75 kW 4-pole 1400	0.32

1) value limited by electric motor power

The total dynamic efficiency (η) of UAL Series actuators, used to determine the DYNAMIC LOAD is calculated as follows:

$$\eta = \eta_1 \times \eta_2 \times \eta_3$$

where:

$\eta_1 = 0.95$ – timing belt transmission efficiency

η_2 – acme screw-bronze nut dynamic efficiency, calculated with reference to the speed

$\eta_3 = 0.9$ – bearings and sealing elements "efficiency"

2) limit value of linear actuator dynamic load capacity (see page 129)

Linear actuators UBA Series

BALL SCREW LINEAR ACTUATORS UBA Series with DC MOTOR
PERFORMANCE with: Duty Cycle $F_i = 100\%$ at ambient temperature $25\text{ }^\circ\text{C}$

LINEAR SPEED [mm/s]	DYNAMIC LOAD [N]	RATIO	MOTOR: POWER [kW] – N° of POLES SPEED [rpm]	SELF-LOCKING COEFFICIENT
UBA 1 with DC motor 24 V 3000 rpm 150 W 8.4 A				
375	300 ¹⁾	RV2	9	0.72
230	500 ¹⁾	RN2	9	0.72
165	700 ¹⁾	RL2	9	0.72
115	1000 ¹⁾	RN1	9	0.72
85	1400 ¹⁾	RL1	9	0.72
UBA 2 with DC motor 24 V 3000 rpm 300 W 15.6 A				
360	650 ¹⁾	RV2	16	0.71
235	1000 ¹⁾	RN2	16	0.71
175	1300 ¹⁾	RL2	16	0.71
120	2000 ¹⁾	RN1	16	0.71
90	2600 ²⁾	RL1	16	0.71
UBA 3 with DC motor 24 V 3000 rpm 500 W 25 A				
480	800 ¹⁾	RV2	26	0.70
240	1600 ¹⁾	RV1	26	0.70
170	2250 ¹⁾	RL2	26	0.70
125	2700 ²⁾	RN1	22	0.70
85	3050 ²⁾	RL1	17.5 (*)	0.70
* - performances with DC motor 24 V 3000 rpm 300 W				
UBA 4 with DC motor 90 V 3000 rpm 750 W 10.6 A				
470	1250 ¹⁾	RV2	11	0.70
260	2250 ¹⁾	RN2	11	0.70
155	3750 ¹⁾	RN1	11	0.70
100	4400 ²⁾	RL1	8.5	0.70

1) value limited by electric motor power; ball screw lifetime $L_{10h} > 1000$ hours (see diagrams on pages 33 ... 35)

The total dynamic efficiency (η) of UBA Series actuators, used to determine the DYNAMIC LOAD is calculated as follows:

$$\eta = \eta_1 \times \eta_2 \times \eta_3$$

where:

$\eta_1 = 0.95$ – timing belt transmission efficiency

$\eta_2 = 0.9$ – ball screw - nut efficiency

$\eta_3 = 0.9$ – bearings and sealing elements "efficiency"

2) value related to the ball screw lifetime $L_{10h} = 1000$ h, with constant load, without load vibrations nor shocks; for different lifetime refer to diagrams on pages 33 ... 35

3) limit value of linear actuator dynamic load capacity (see page 128)

Linear actuators UAL Series

ACME SCREW LINEAR ACTUATORS UAL Series with DC MOTOR
PERFORMANCE with: Duty Cycle $F_i = 30\%$ over 10 min at ambient temperature 25 °C

LINEAR SPEED [mm/s]	DYNAMIC LOAD [N]	RATIO	MOTOR: POWER [kW] – N° of POLES SPEED [rpm]	SELF-LOCKING COEFFICIENT
UAL 1 with DC motor 24 V 3000 rpm 150 W 8.4 A				
300	350 ¹⁾	RV2	9	0.51
185	500 ¹⁾	RN2	9	0.51
130	700 ¹⁾	RL2	9	0.51
112	700 ¹⁾	RV1	9	0.32
70	1000 ¹⁾	RN1	9	0.32
50	1400 ¹⁾	RL1	9	0.32
UAL 2 with DC motor 24 V 3000 rpm 300 W 15.6 A				
285	700 ¹⁾	RV2	16	0.48
185	1050 ¹⁾	RN2	16	0.48
140	1350 ¹⁾	RL2	16	0.48
93	1700 ¹⁾	RN1	16	0.35
70	2200 ¹⁾	RL1	16	0.35
UAL 3 with DC motor 24 V 3000 rpm 500 W 25 A				
384	900 ¹⁾	RV2	26	0.46
200	1600 ¹⁾	RN2	26	0.46
137	2300 ¹⁾	RL2	26	0.46
100	2600 ¹⁾	RN1	26	0.32
68	3600 ¹⁾	RL1	26	0.32
UAL 4 with DC motor 90 V 3000 rpm 750 W 10.6 A				
470	1100 ¹⁾	RV2	11	0.46
250	2000 ¹⁾	RN2	12	0.46
170	2750 ¹⁾	RL2	11	0.46
125	3150 ¹⁾	RN1	11	0.32
85	4500 ¹⁾	RL1	11	0.32

1) value limited by electric motor power

The total dynamic efficiency (η) of UAL Series actuators, used to determine the DYNAMIC LOAD is calculated as follows:

$$\eta = \eta_1 \times \eta_2 \times \eta_3$$

where:

$\eta_1 = 0.95$ – timing belt transmission efficiency

η_2 – acme screw-bronze nut dynamic efficiency, calculated with reference to the speed

$\eta_3 = 0.9$ – bearings and sealing elements "efficiency"

2) limit value of linear actuator dynamic load capacity (see page 129)

Linear actuators UBA Series

BALL SCREW LINEAR ACTUATORS UBA Series, size 1 – 2 – 3 – 4
AC 3-phase or 1-phase MOTOR – with Magnetic Stroke Limit Switches FCM
STANDARD STROKE LENGTHS

		STROKE CODE	C100	C200	C300	C400	C500	C600	C700	C800	S2	T	Q2
UBA 1	R_1	STROKE [mm]	100	200	300	400	500	600	700	800	287	250	287
	R_2										303	266	303
UBA 2	R_1										307	263	310
	R_2										330	286	333
UBA 3	R_1										342	296	348
	R_2										367	321	373
UBA 4	R_1										406	352	418
	R_2										419	365	431

NOTE: Different stroke lengths available on request. $L_a = L_c + \text{STROKE}$

For stroke lengths longer than 800 mm it is necessary to increase the guided length between push rod and outer tube to avoid axial backlash. Dimensions **S2**, **T** and **Q2** shall be considered increased by 200 mm for stroke lengths up to 1500 mm.

For stroke lengths longer than 1500 mm, please, contact SERVOMECH.

	A	B	B1	C	CH	∅ D1	∅ D2	E	G	H1	H2	H3	I	L2
UBA 1	85	52	110	114	22	25	36	189	15	58	75	55	90	193
UBA 2	94	60	115	127	27	30	45	217	17	64	90	62	104	229
UBA 3	106	71	124	135	30	35	55	247	20	68	90	75	121	304
UBA 4	120	77	141	161	36	40	60	293	24	81	95	90	138	340

	R1	∅ X	a	b	c	e	∅ g	h	∅ i	l	∅ o	r1	s	t
UBA 1	17	110	54	28	73	46	10	36	M10×1.5	17	9	18	10	4
UBA 2	20	123	62	32	80	50	12	40	M12×1.75	18	9	20	11	8
UBA 3	20	150	72	38	90	58	14	45	M14×2	24	9	22	12	8
UBA 4	22	170	85	55	110	81	20	58	M20×1.5	27	11	29	15	15

4

FRONT ATTACHMENT Dimensions

	∅ a	∅ b	∅ c	∅ D1	∅ d2	g	∅ g1	k	p	p1
UBA 1	55	40	5.5	25	28	10	10	20	31	45
UBA 2	60	45	6.5	30	32	12	12	24	36	52
UBA 3	65	50	6.5	35	36	14	14	27	36	54
UBA 4	80	60	8.5	40	50	20	20	40	53	78

	q	r	s2	s3	t1	∅ t1	u	w	w1	w2	w3
UBA 1	8	27	14	11	26	14	15	49	61	20	12
UBA 2	9	28	16	12	32	16	18	56	70	24	14
UBA 3	9	32	19	14	36	18	21	65	81	28	16
UBA 4	10	42	25	18	42	25	27	90	115	40	25

MAGNETIC STROKE LIMIT SWITCHES FCM Technical features and dimensions

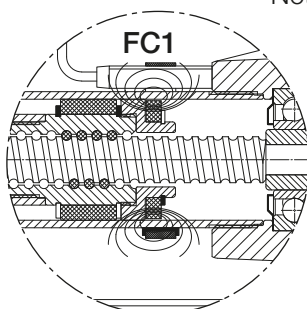

Note: - Additional extra magnetic REED SWITCHES are available for intermediate positions.

- The minimum distance between the REED SWITCHES must be of at least 10 mm.

- REED SWITCH Normally Closed (NC) R = 39 mm

- REED SWITCH Change-over (NC+NO) R = 39 mm

- REED SWITCH Normally Open (NO) R = 29 mm

Linear actuators UBA Series

BALL SCREW LINEAR ACTUATORS UBA Series, size 1 – 2 – 3 – 4
DC MOTOR – with Magnetic Stroke Limit Switches FCM

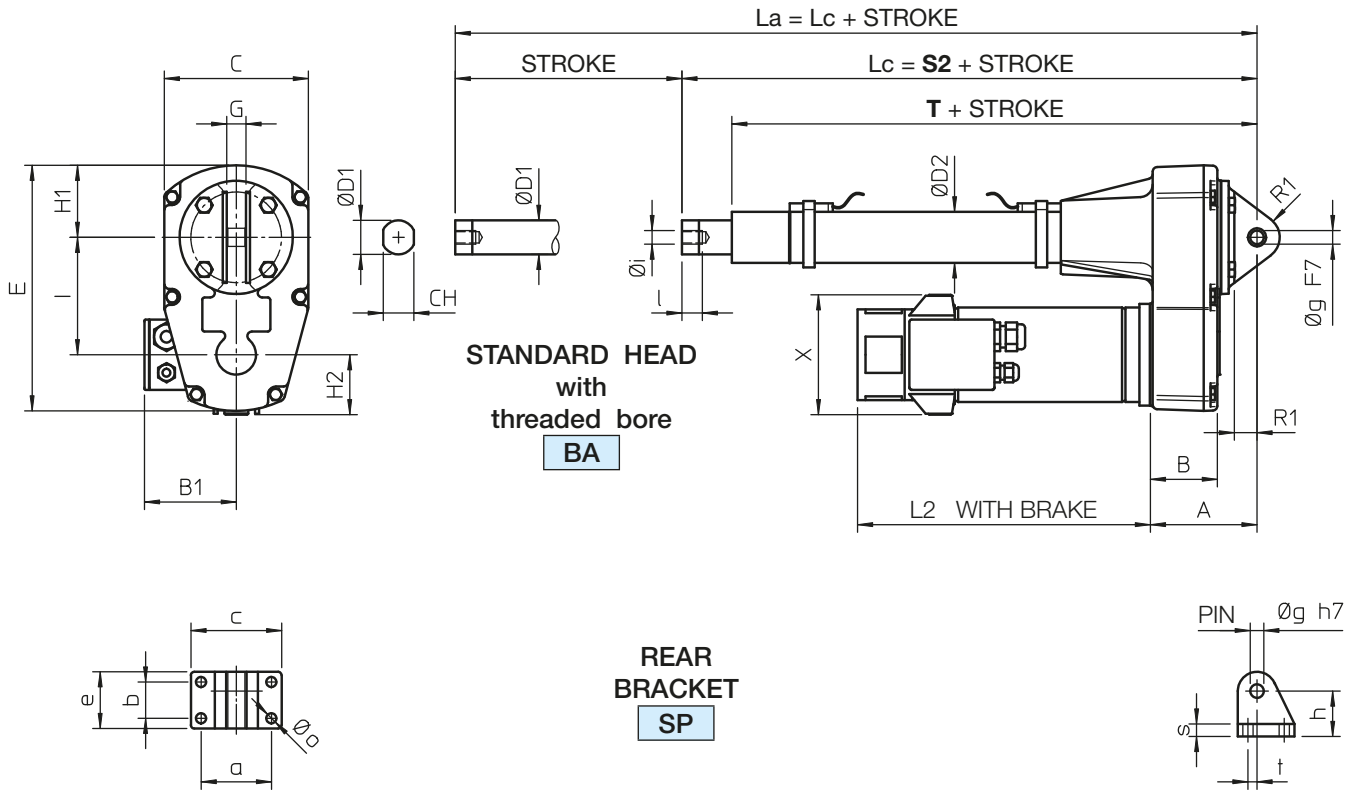

Lc - RETRACTED ACTUATOR length
La - EXTENDED ACTUATOR length

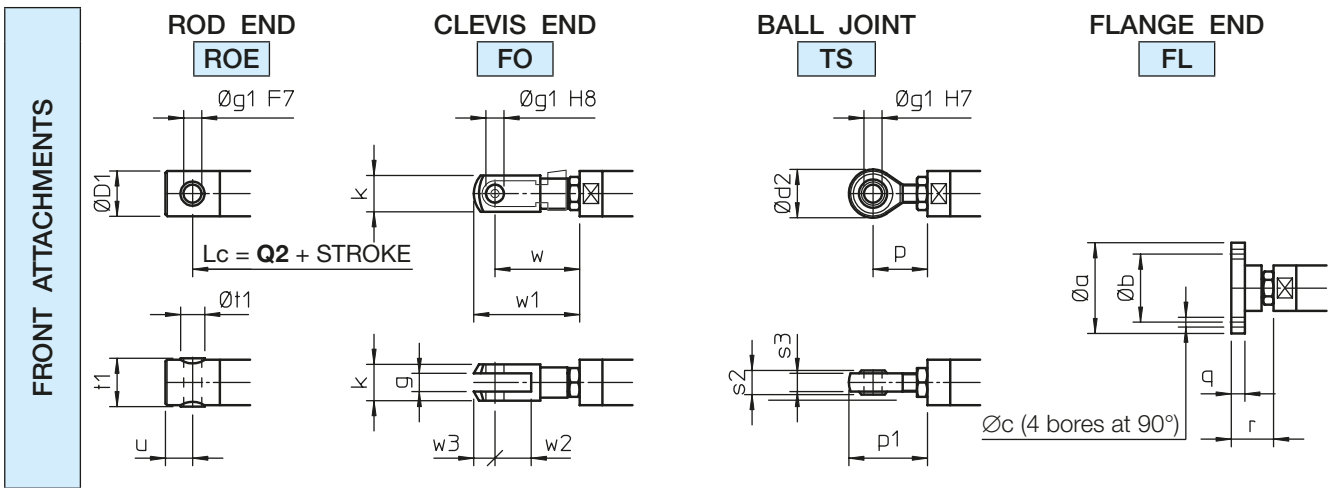

MAGNETIC STROKE LIMIT SWITCHES FCM Dimensions

	L	
	REED CONTACT NC or (NC+NO)	NO
UBA 1	42	47
UBA 2	51	56
UBA 3	59	64
UBA 4	69	74

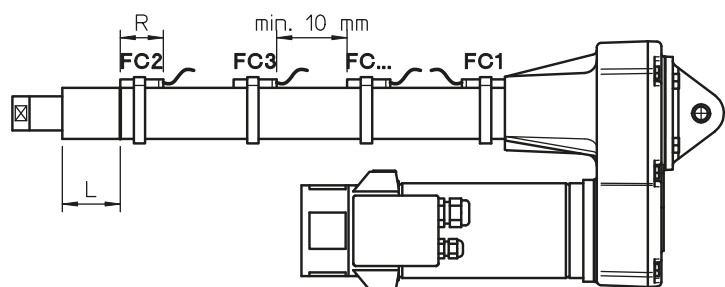

Linear actuators UBA Series

BALL SCREW LINEAR ACTUATORS UBA Series, size 1 – 2 – 3 – 4
DC MOTOR – with Magnetic Stroke Limit Switches FCM
STANDARD STROKE LENGTHS

		STROKE CODE	C100	C200	C300	C400	C500	C600	C700	C800	S2	T	Q2
UBA 1	R_1	STROKE [mm]	100	200	300	400	500	600	700	800	287	250	287
	R_2										303	266	303
UBA 2	R_1										307	263	310
	R_2										330	286	333
UBA 3	R_1										342	296	348
	R_2										367	321	373
UBA 4	R_1										406	352	418
	R_2										419	365	431

NOTE: Different stroke lengths available on request. $L_a = L_c + \text{STROKE}$

For stroke lengths longer than 800 mm it is necessary to increase the guided length between push rod and outer tube to avoid axial backlash. Dimensions **S2**, **T** and **Q2** shall be considered increased by 200 mm for stroke lengths up to 1500 mm.

For stroke lengths longer than 1500 mm, please, contact SERVOMECH.

	A	B	B1	C	CH	∅ D1	∅ D2	E	G	H1	H2	H3	I	L2
UBA 1	85	52	80	114	22	25	36	189	15	58	75	55	90	193
UBA 2	94	60	80	127	27	30	45	217	17	64	90	62	104	229
UBA 3	106	71	80	135	30	35	55	247	20	68	90	75	121	304
UBA 4	120	77	118	161	36	40	60	293	24	81	95	90	138	340

	R1	X	a	b	c	e	∅ g	h	∅ i	l	∅ o	r1	s	t
UBA 1	17	107	54	28	73	46	10	36	M10×1.5	17	9	18	10	4
UBA 2	20	107	62	32	80	50	12	40	M12×1.75	18	9	20	11	8
UBA 3	20	107	72	38	90	58	14	45	M14×2	24	9	22	12	8
UBA 4	22	138	85	55	110	81	20	58	M20×1.5	27	11	29	15	15

4

FRONT ATTACHMENT Dimensions

	∅ a	∅ b	∅ c	∅ D1	∅ d2	g	∅ g1	k	p	p1
UBA 1	55	40	5.5	25	28	10	10	20	31	45
UBA 2	60	45	6.5	30	32	12	12	24	36	52
UBA 3	65	50	6.5	35	36	14	14	27	36	54
UBA 4	80	60	8.5	40	50	20	20	40	53	78

	q	r	s2	s3	t1	∅ t1	u	w	w1	w2	w3
UBA 1	8	27	14	11	26	14	15	49	61	20	12
UBA 2	9	28	16	12	32	16	18	56	70	24	14
UBA 3	9	32	19	14	36	18	21	65	81	28	16
UBA 4	10	42	25	18	42	25	27	90	115	40	25

MAGNETIC STROKE LIMIT SWITCHES FCM Technical features and dimensions

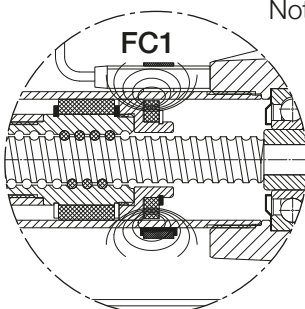

- Note: - Additional extra magnetic REED SWITCHES are available for intermediate positions.
 - The minimum distance between the REED SWITCHES must be of at least 10 mm.
- | | | | |
|---------------|-----------------|---------|-----------|
| - REED SWITCH | Normally Closed | (NC) | R = 39 mm |
| - REED SWITCH | Change-over | (NC+NO) | R = 39 mm |
| - REED SWITCH | Normally Open | (NO) | R = 29 mm |

Linear actuators UBA Series

BALL SCREW LINEAR ACTUATOR UBA 5 AC 3-phase MOTOR — with Proximity Stroke Limit Switches FCP

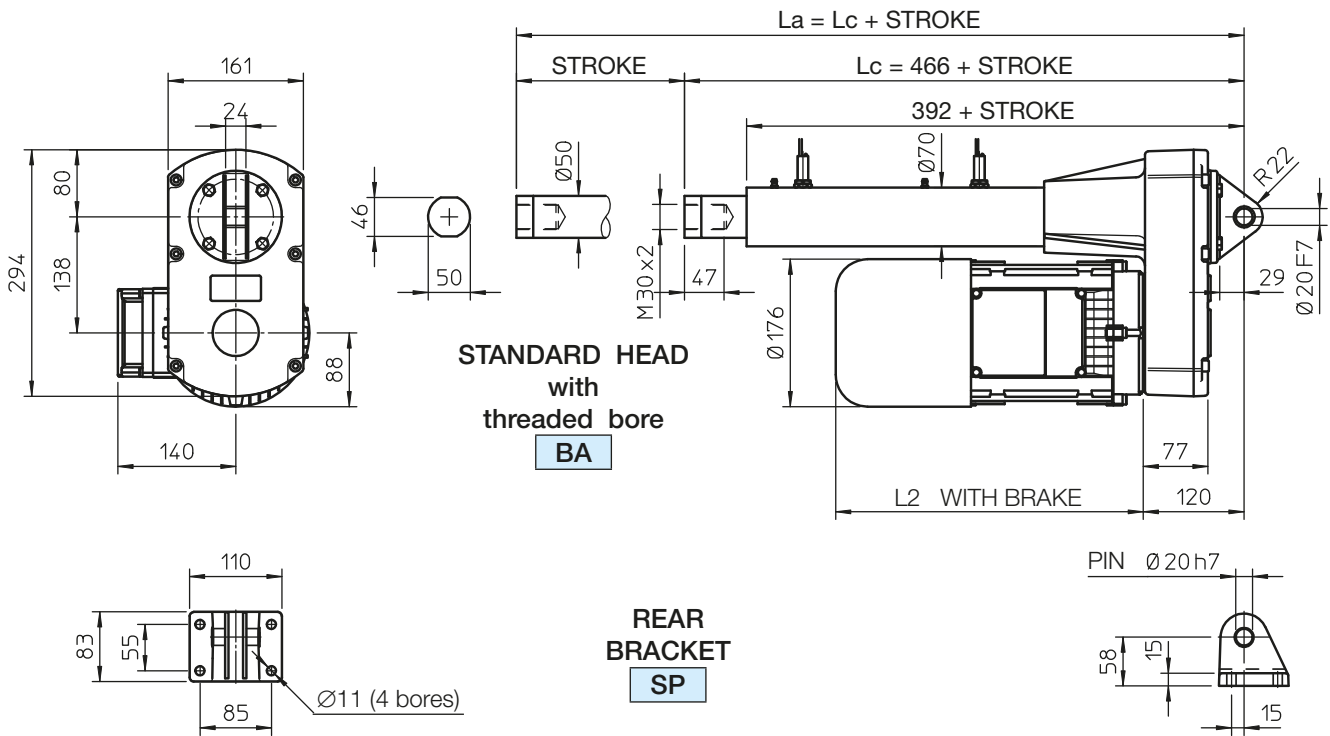

L_c - RETRACTED ACTUATOR length
 L_a - EXTENDED ACTUATOR length

NOTE: The STROKE that the actuator can perform corresponds to the STROKE CODE of the ordering code (STROKE CODE C100 means STROKE = 100 mm)
 For stroke lengths longer than 800 mm it is necessary to increase the guided length between push rod and outer tube to avoid axial backlash. The length L_c shall be considered increased by 200 mm for stroke lengths up to 1500 mm.
 For stroke lengths longer than 1500 mm please contact SERVOMECH.

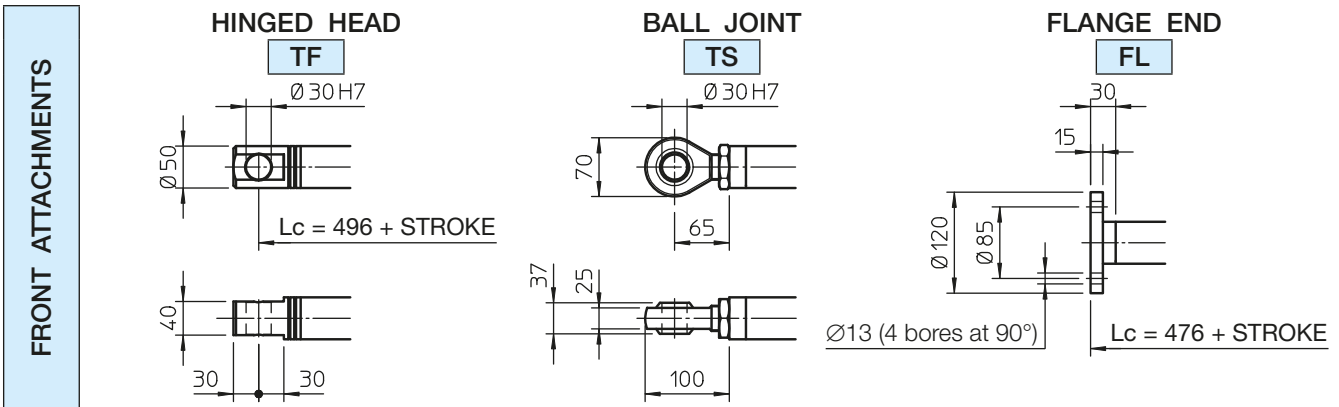

Linear actuators UAL Series

ACME SCREW LINEAR ACTUATOR UAL 5 AC 3-phase MOTOR – with Proximity Stroke Limit Switches FCP

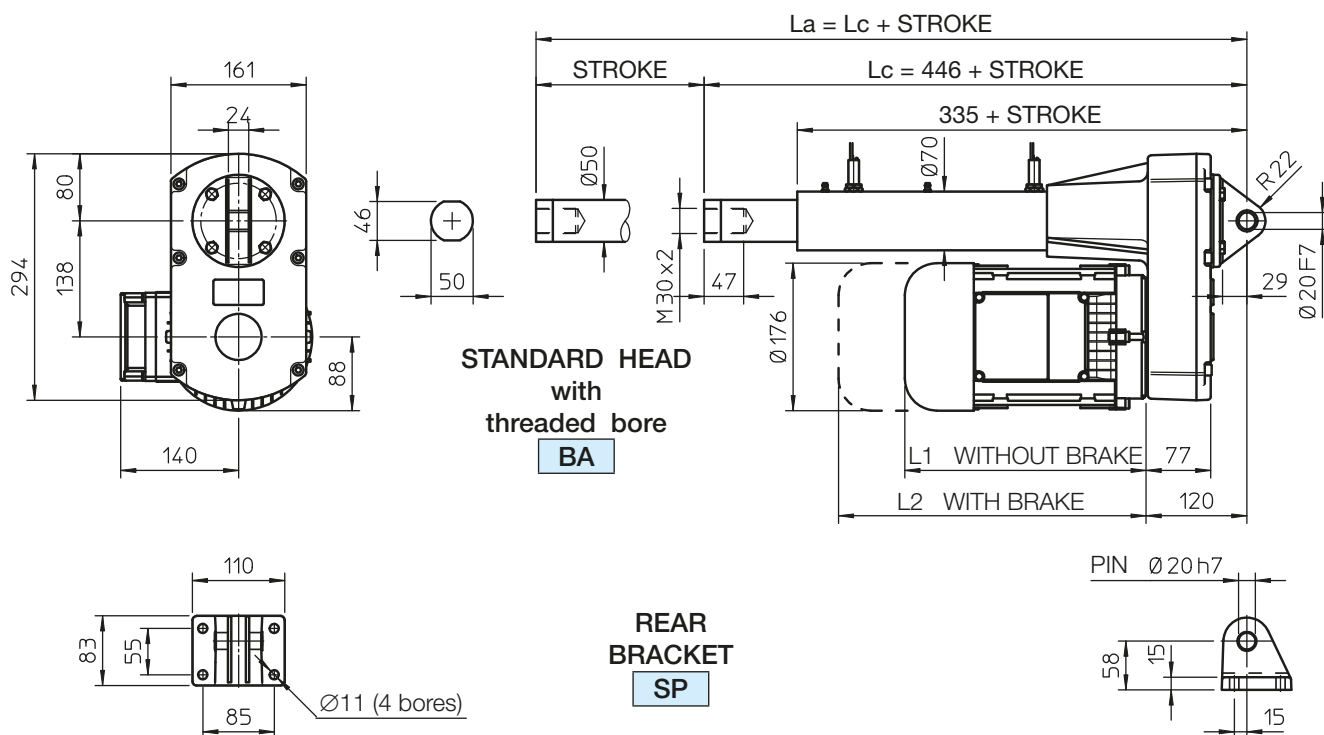

Lc - RETRACTED ACTUATOR length
La - EXTENDED ACTUATOR length

NOTE: The STROKE that the actuator can perform corresponds to the STROKE CODE of the ordering code (STROKE CODE C100 means STROKE = 100 mm)

For stroke lengths longer than 800 mm it is necessary to increase the guided length between push rod and outer tube to avoid axial backlash. The length Lc shall be considered increased by 200 mm for stroke lengths up to 1500 mm.

For stroke lengths longer than 1500 mm please contact SERVOMECH.

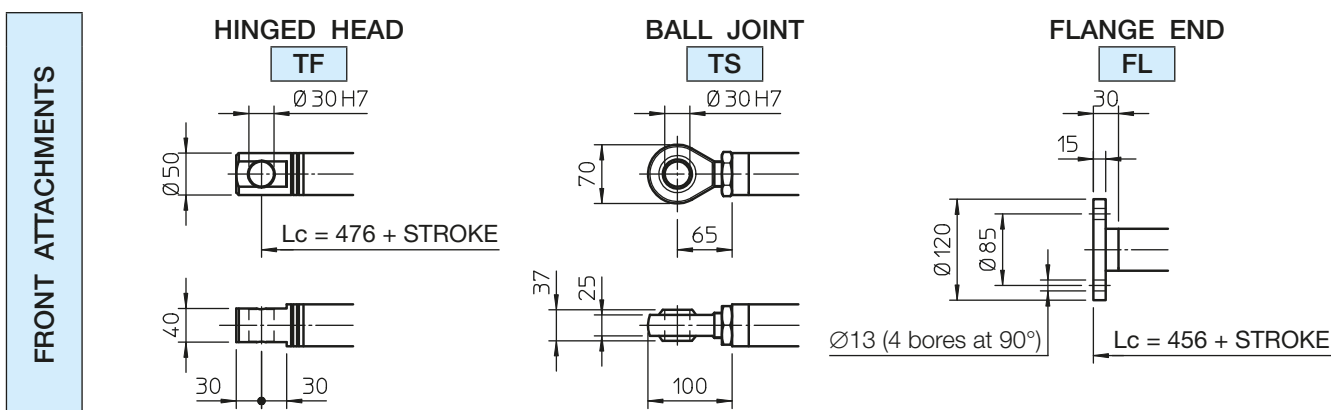

Linear actuators UAL Series

ACME SCREW LINEAR ACTUATORS UAL Series, size 1 – 2 – 3 – 4
 AC 3-phase or 1-phase MOTOR – with Magnetic Stroke Limit Switches FCM

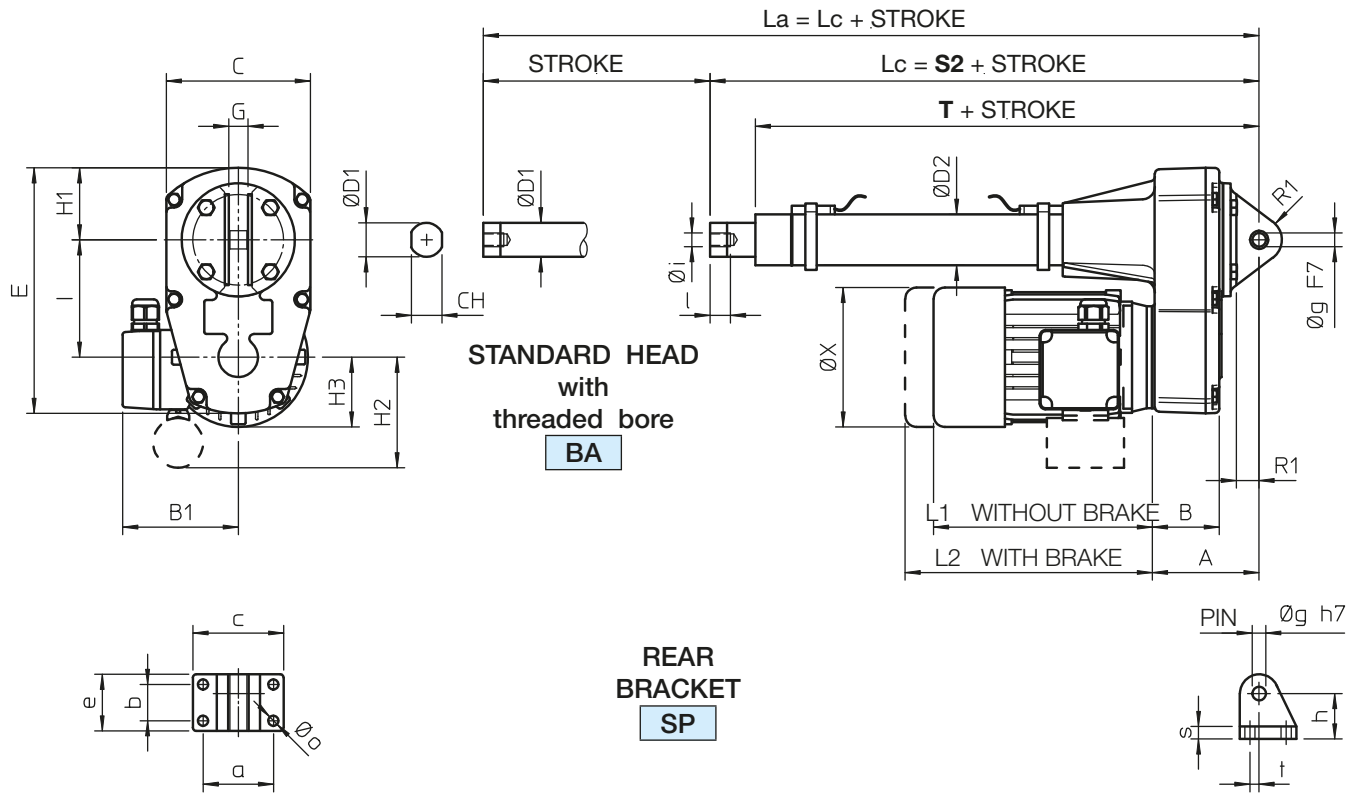

Lc - RETRACTED ACTUATOR length
 La - EXTENDED ACTUATOR length

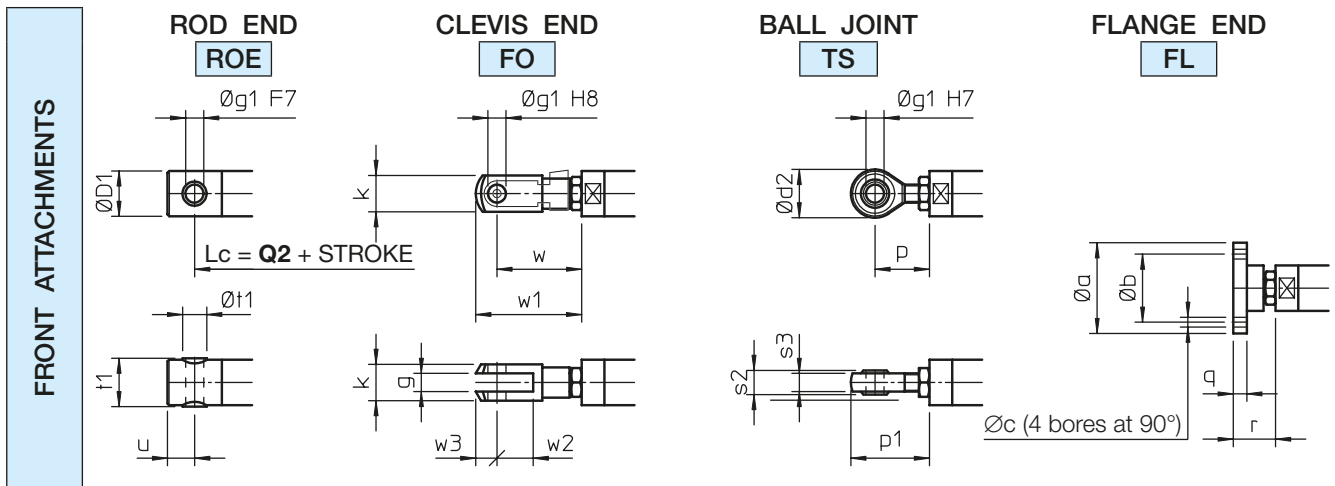

MAGNETIC STROKE LIMIT SWITCHES FCM Dimensions

	L	
	REED CONTACT NC or (NC+NO)	NO
UAL 1	42	47
UAL 2	51	56
UAL 3	59	64
UAL 4	69	74

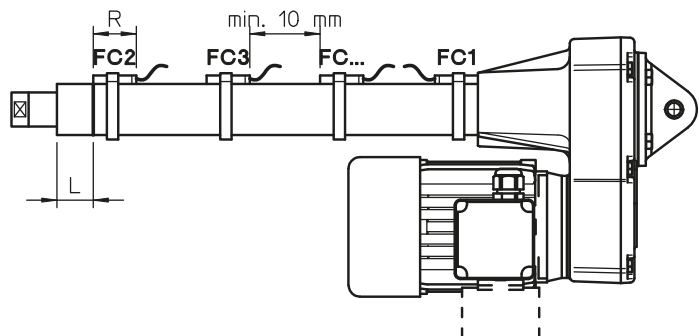

Linear actuators UAL Series

ACME SCREW LINEAR ACTUATORS UAL Series, size 1 – 2 – 3 – 4
AC 3-phase or 1-phase MOTOR – with Magnetic Stroke Limit Switches FCM

STANDARD STROKE LENGTHS

	STROKE CODE	C100	C200	C300	C400	C500	C600	C700	C800	S2	T	Q2
UAL 1	STROKE [mm]	100	200	300	400	500	600	700	800	265	232	265
UAL 2										284	244	287
UAL 3										317	274	324
UAL 4										377	323	389

NOTE: Different stroke lengths available on request. $L_a = L_c + \text{STROKE}$

For stroke lengths longer than 800 mm it is necessary to increase the guided length between push rod and outer tube to avoid axial backlash. Dimensions **S2**, **T** and **Q2** shall be considered increased by 200 mm for stroke lengths up to 1500 mm.

For stroke lengths longer than 1500 mm, please, contact SERVOMECH.

	A	B	B1	C	CH	∅ D1	∅ D2	E	G	H1	H2	H3	I	L1	L2
UAL 1	85	52	110	114	22	25	36	189	15	58	75	55	90	167	193
UAL 2	94	60	115	127	27	30	45	217	17	64	90	62	104	193	229
UAL 3	106	71	124	135	30	35	55	247	20	68	90	75	121	215	304
UAL 4	120	77	141	161	36	40	60	293	24	81	95	90	138	235	340

	R1	∅ X	a	b	c	e	∅ g	h	∅ i	l	∅ o	r1	s	t
UAL 1	17	110	54	28	73	46	10	36	M10×1.5	17	9	18	10	4
UAL 2	20	123	62	32	80	50	12	40	M12×1.75	18	9	20	11	8
UAL 3	20	150	72	38	90	58	14	45	M14×2	24	9	22	12	8
UAL 4	22	170	85	55	110	81	20	58	M20×1.5	27	11	29	15	15

4

FRONT ATTACHMENT Dimensions

	∅ a	∅ b	∅ c	∅ D1	∅ d2	g	∅ g1	k	p	p1
UAL 1	55	40	5.5	25	28	10	10	20	31	45
UAL 2	60	45	6.5	30	32	12	12	24	36	52
UAL 3	65	50	6.5	35	36	14	14	27	36	54
UAL 4	80	60	8.5	40	50	20	20	40	53	78

	q	r	s2	s3	t1	∅ t1	u	w	w1	w2	w3
UAL 1	8	27	14	11	26	14	15	49	61	20	12
UAL 2	9	28	16	12	32	16	18	56	70	24	14
UAL 3	9	32	19	14	36	18	21	65	81	28	16
UAL 4	10	42	25	18	42	25	27	90	115	40	25

MAGNETIC STROKE LIMIT SWITCHES FCM Technical features and dimensions

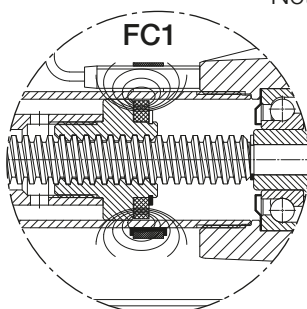

Note: - Additional extra magnetic REED SWITCHES are available for intermediate positions.

- The minimum distance between the REED SWITCHES must be of at least 10 mm.

- REED SWITCH Normally Closed (NC) R = 39 mm

- REED SWITCH Change-over (NC+NO) R = 39 mm

- REED SWITCH Normally Open (NO) R = 29 mm

Linear actuators UAL Series

ACME SCREW LINEAR ACTUATORS UAL Series, size 1 – 2 – 3 – 4
DC MOTOR – with Magnetic Stroke Limit Switches FCM

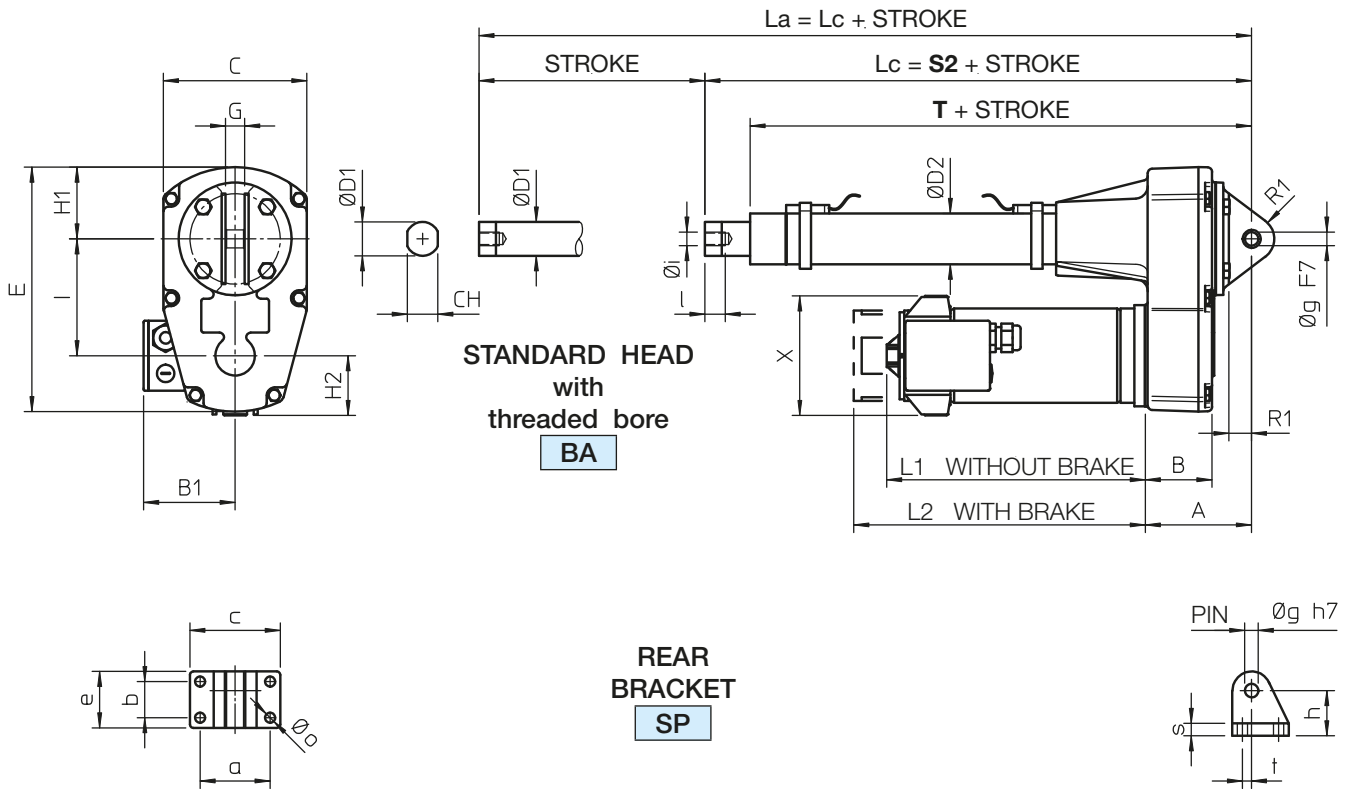

L_c - RETRACTED ACTUATOR length
 L_a - EXTENDED ACTUATOR length

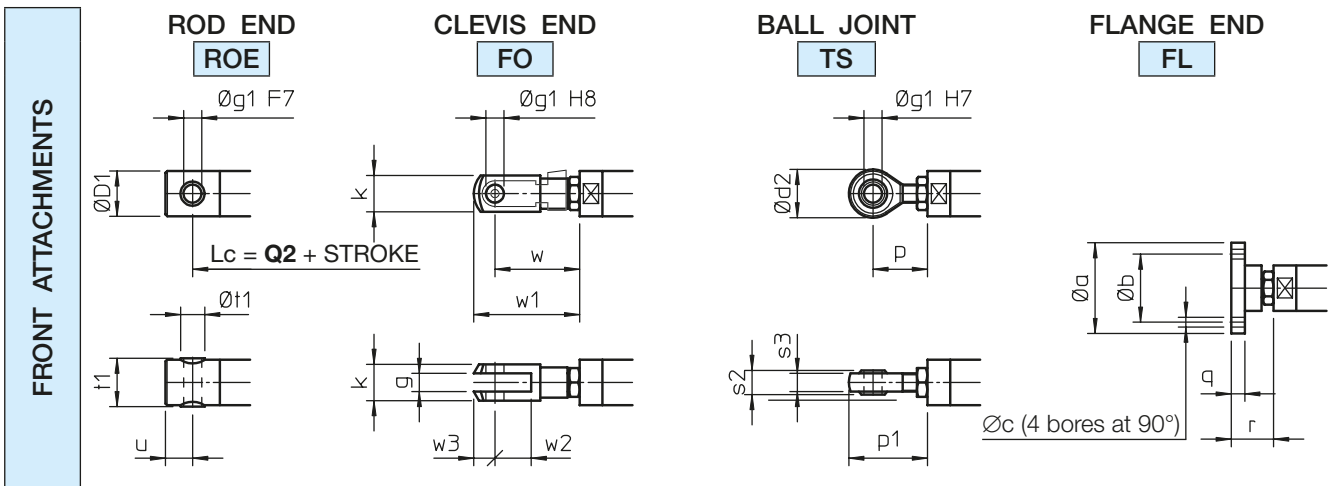

MAGNETIC STROKE LIMIT SWITCHES FCM Dimensions

	L	
	REED CONTACT NC or (NC+NO)	NO
UAL 1	42	47
UAL 2	51	56
UAL 3	59	64
UAL 4	69	74

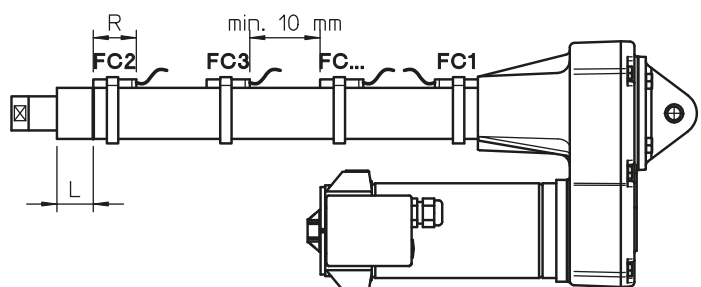

Linear actuators UAL Series

ACME SCREW LINEAR ACTUATORS UAL Series, size 1 – 2 – 3 – 4
DC MOTOR – with Magnetic Stroke Limit Switches FCM
STANDARD STROKE LENGTHS

	STROKE CODE	C100	C200	C300	C400	C500	C600	C700	C800	S2	T	Q2
UAL 1	STROKE [mm]	100	200	300	400	500	600	700	800	265	232	265
UAL 2										284	244	287
UAL 3										317	274	324
UAL 4										377	323	389

NOTE: Different stroke lengths available on request. $L_a = L_c + \text{STROKE}$

For stroke lengths longer than 800 mm it is necessary to increase the guided length between push rod and outer tube to avoid axial backlash. Dimensions **S2**, **T** and **Q2** shall be considered increased by 200 mm for stroke lengths up to 1500 mm.

For stroke lengths longer than 1500 mm, please, contact SERVOMECH.

	A	B	B1	C	CH	∅ D1	∅ D2	E	G	H1	H2	H3	I	L1	L2
UAL 1	85	52	110	114	22	25	36	189	15	58	75	55	90	167	193
UAL 2	94	60	115	127	27	30	45	217	17	64	90	62	104	193	229
UAL 3	106	71	124	135	30	35	55	247	20	68	90	75	121	215	304
UAL 4	120	77	141	161	36	40	60	293	24	81	95	90	138	235	340

	R1	∅ X	a	b	c	e	∅ g	h	∅ i	l	∅ o	r1	s	t
UAL 1	17	110	54	28	73	46	10	36	M10×1.5	17	9	18	10	4
UAL 2	20	123	62	32	80	50	12	40	M12×1.75	18	9	20	11	8
UAL 3	20	150	72	38	90	58	14	45	M14×2	24	9	22	12	8
UAL 4	22	170	85	55	110	81	20	58	M20×1.5	27	11	29	15	15

4

FRONT ATTACHMENT Dimensions

	∅ a	∅ b	∅ c	∅ D1	∅ d2	g	∅ g1	k	p	p1
UAL 1	55	40	5.5	25	28	10	10	20	31	45
UAL 2	60	45	6.5	30	32	12	12	24	36	52
UAL 3	65	50	6.5	35	36	14	14	27	36	54
UAL 4	80	60	8.5	40	50	20	20	40	53	78

	q	r	s2	s3	t1	∅ t1	u	w	w1	w2	w3
UAL 1	8	27	14	11	26	14	15	49	61	20	12
UAL 2	9	28	16	12	32	16	18	56	70	24	14
UAL 3	9	32	19	14	36	18	21	65	81	28	16
UAL 4	10	42	25	18	42	25	27	90	115	40	25

MAGNETIC STROKE LIMIT SWITCHES FCM Technical features and dimensions

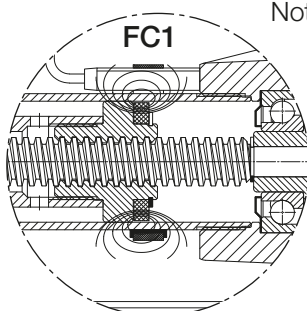

- Note: - Additional extra magnetic REED SWITCHES are available for intermediate positions.
 - The minimum distance between the REED SWITCHES must be of at least 10 mm.
- | | | | |
|---------------|-----------------|---------|-----------|
| - REED SWITCH | Normally Closed | (NC) | R = 39 mm |
| - REED SWITCH | Change-over | (NC+NO) | R = 39 mm |
| - REED SWITCH | Normally Open | (NO) | R = 29 mm |

Linear actuators UBA Series and UAL Series

4.5 OPTIONS AND ACCESSORIES

ELECTRIC MOTOR TERMINAL BOX POSITION

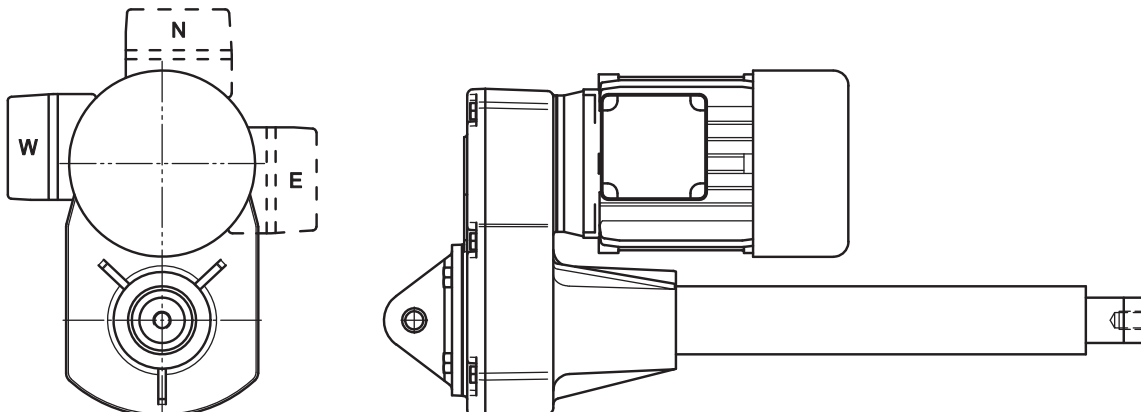

STANDARD side: W
ON REQUEST side E ; N

POSITION OF FRONT AND REAR ACTUATOR ATTACHMENT

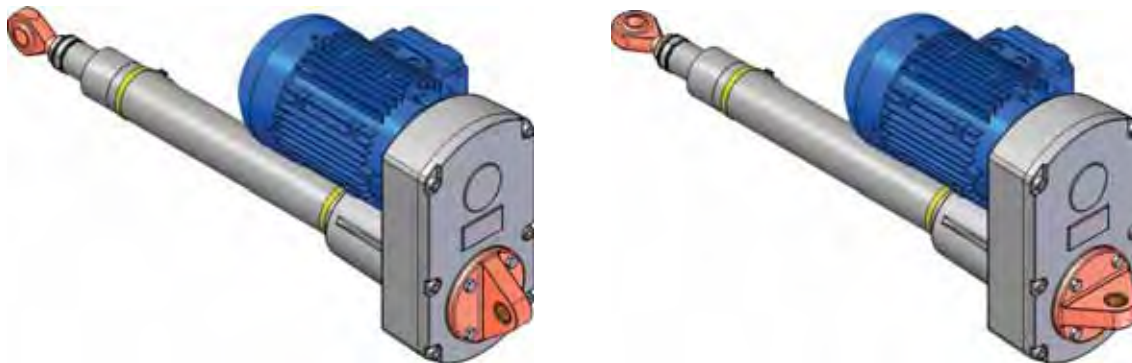

STANDARD

ON REQUEST: turned at 90°
Code: RPT 90°

INTERMEDIATE FLANGE Code FI

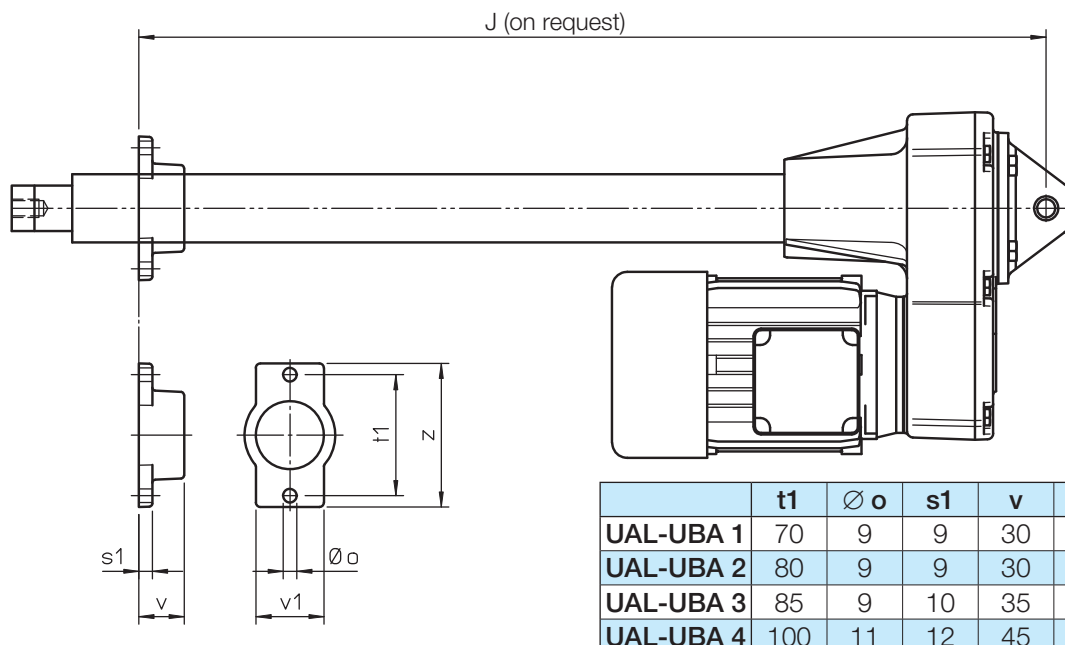

NOTE: the intermediate flange FI can be used as sustainer only and not to support the axial load!

Linear actuators UBA Series and UAL Series

4.5 ACCESSORIES

MAGNETIC STROKE END SWITCHES Code FCM

The MAGNETIC STROKE END SWITCHES FCM allow to limit the actuator stroke length avoiding to reach the extreme positions (mechanical stop) and preventing damage. Using more switches it is also possible to set intermediate positions along the actuator stroke length.

These reeds can be used to stop the actuator or simply to signal its position during the linear motion.

A magnetic ring on the actuator push rod creates a toroidal magnetic field of 100 Gauß.

The stroke end switches must be fixed on the push rod and are activated by the toroidal magnetic field independently of their angular position.

The outer tubes are made in non-magnetic material, such as anodized aluminium or stainless steel, thus allowing the external transmission of the magnetic field and therefore activation of the reeds switches.

The standard construction of actuators with FCM includes the outer tube in anodized aluminium; tubes in stainless steel are available on request.

The stroke end switches must be fixed with clamps in non-magnetic material and, to be activated, they must be mounted with the side with the code number upwards (the sensor code number shall be visible).

WARNING: Max. performances stated in this catalogue and/or technical data sheets supplied with the actuator must not be exceeded, in order to avoid damages and malfunction!
The magnetic reed switches can work only if connected to a control circuit to activate electric relay. They shall not be connected in series between the power supply and the electric motor.

- RETRACTED ACTUATOR (Lc) position: sensor FC 1
- EXTENDED ACTUATOR (La) position: sensor FC 2

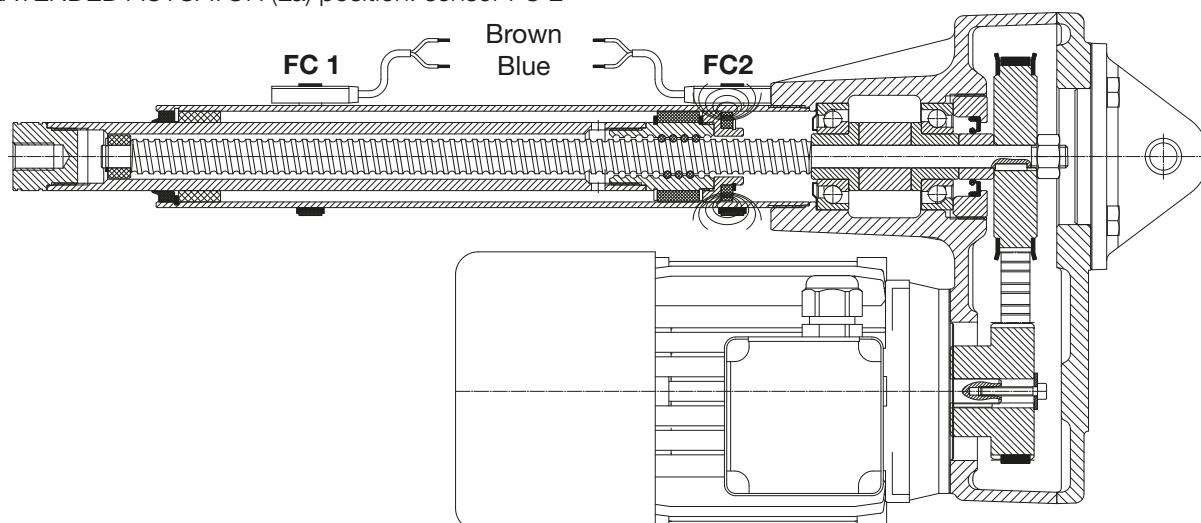

The toroidal magnetic field created by the internal magnetic ring has an arch-like form. When using more contact reeds for intermediate positions, it shall be considered that the same reed switch can give the signal in 2 different positions, depending on the actuator motion which can be retracting or extending. To know the difference between these 2 positions please contact SERVOMECH.

The position of the reed switches can be adjusted by changing the fixing clamp position on the outer tube.

The MAGNETIC STROKE END SWITCHES FCM are available for actuators of both UAL and UBA Series, for size 1 ... 4.

NOTE: The FCM is not available if the actuator is equipped with ANTI-TURN device AR.

Linear actuators UBA Series and UAL Series

4.5 ACCESSORIES

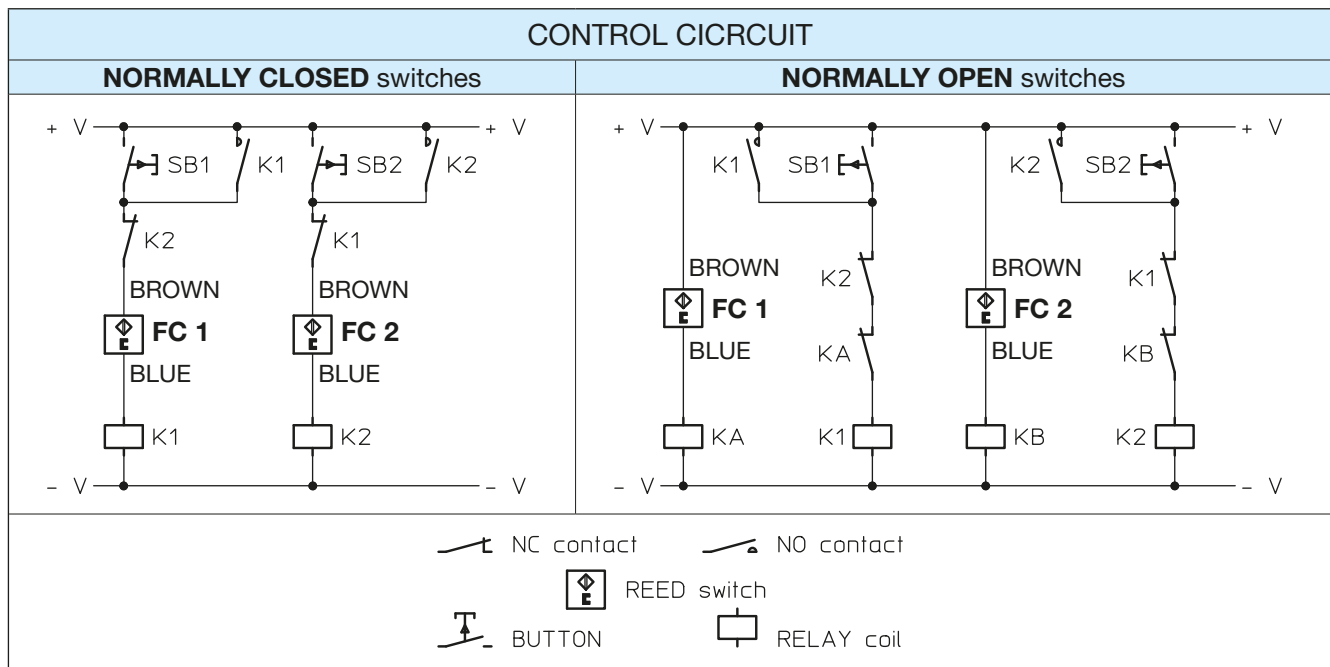

The extreme reed switches positions are:

- RETRACTED ACTUATOR (Lc) position: the reed switch fixed on the tube up to the actuator housing
- EXTENDED ACTUATOR (La) position: the reed switch must exceed the limit marked on the outer tube. This limit position is given on the tables stating the dimensions for standard stroke lengths up to 800 mm.

For special stroke lengths longer than 800 mm, the limit position is the one marked on the tube, otherwise please contact SERVOMECH (also in this case it is marked on the actuator).

ELECTRIC FEATURES		
Voltage	(3 ... 130) V DC	(3 ... 130) V AC
Max. commutable power	20 W	20 VA
Max. commutable current	300 mA (resistive load)	
Max. inductive load	3 W (simple coil)	

The reed switches are equipped with a multicore cable 2 × 0.25 mm², standard length 2 m.

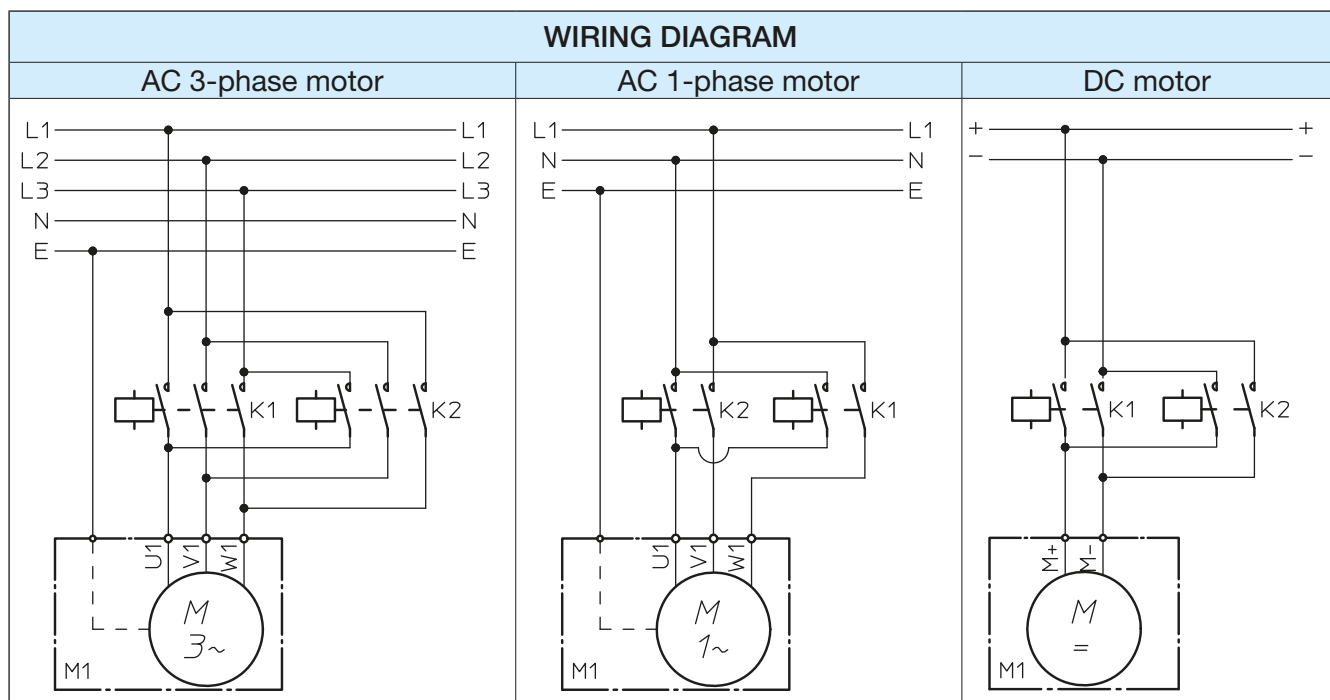

Linear actuators UBA Series and UAL Series

4.5 ACCESSORIES

INDUCTIVE PROXIMITY STROKE END SWITCHES Code FCP

The INDUCTIVE PROXIMITY STROKE END SWITCHES FCP allow the actuator to stop before reaching the internal mechanical stop avoiding damage. They can be also used to fix intermediate positions along the actuator stroke length.

The INDUCTIVE PROXIMITY STROKE END SWITCHES are fixed directly on the actuator outer tube in the required position. Their position is not adjustable. Standard proximity switches are normally closed.

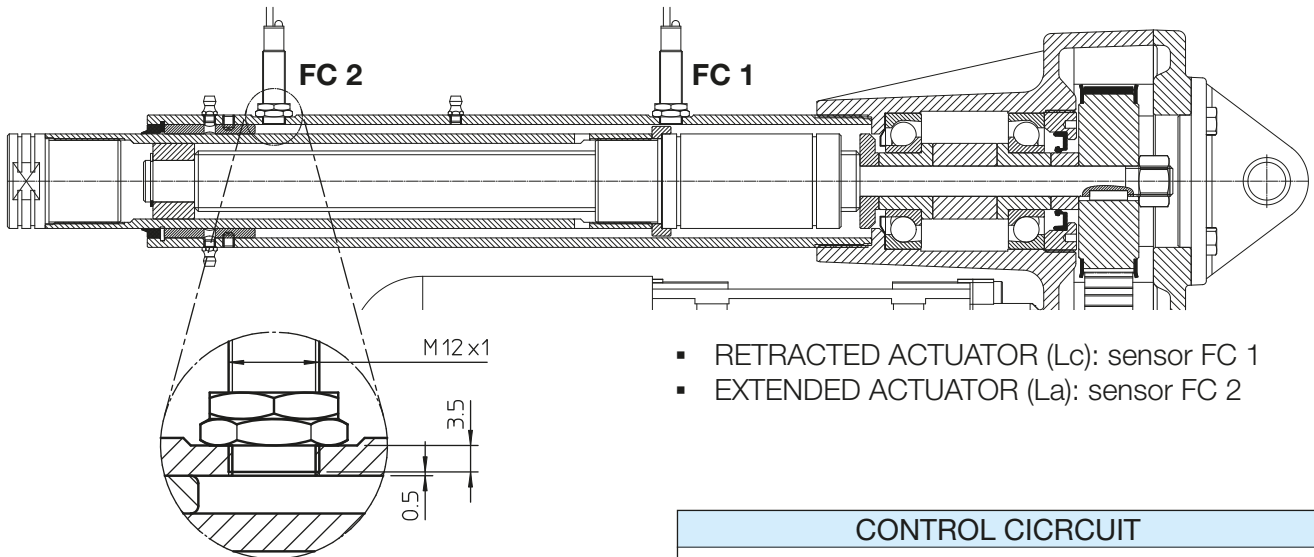

- RETRACTED ACTUATOR (Lc): sensor FC 1
- EXTENDED ACTUATOR (La): sensor FC 2

ELECTRIC FEATURES	
Voltage	(10 ... 30) V DC
Max. output current	200 mA
Voltage drop (activated switch)	< 3 V (at 200 mA)

The switches are equipped with a multicore cable 3 × 0.2 mm², standard length 2 m.

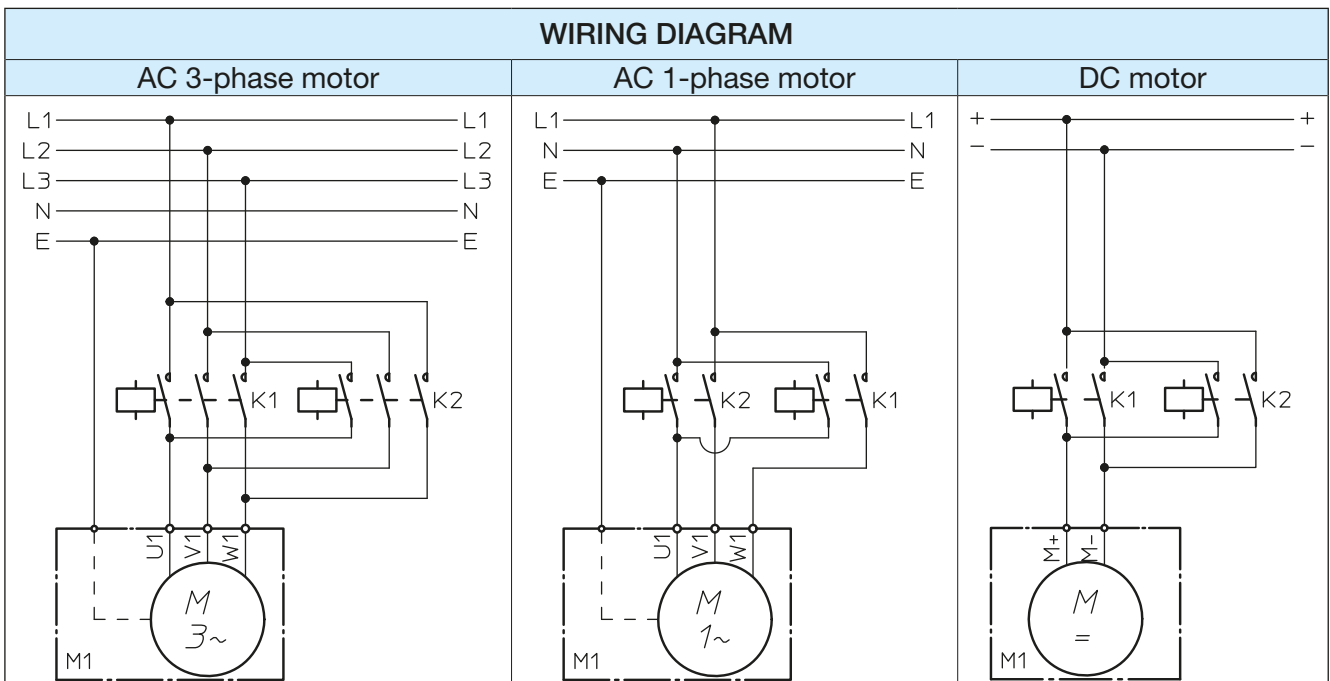
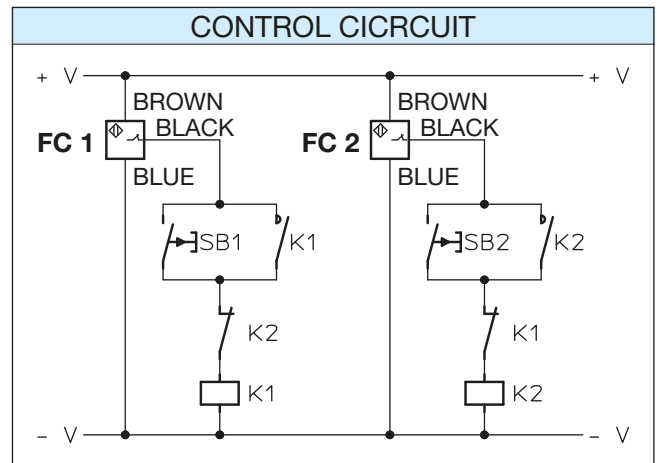
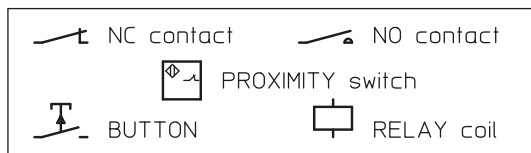

Linear actuators UBA Series and UAL Series

4.5 ACCESSORIES

ANTI-TURN device Code AR

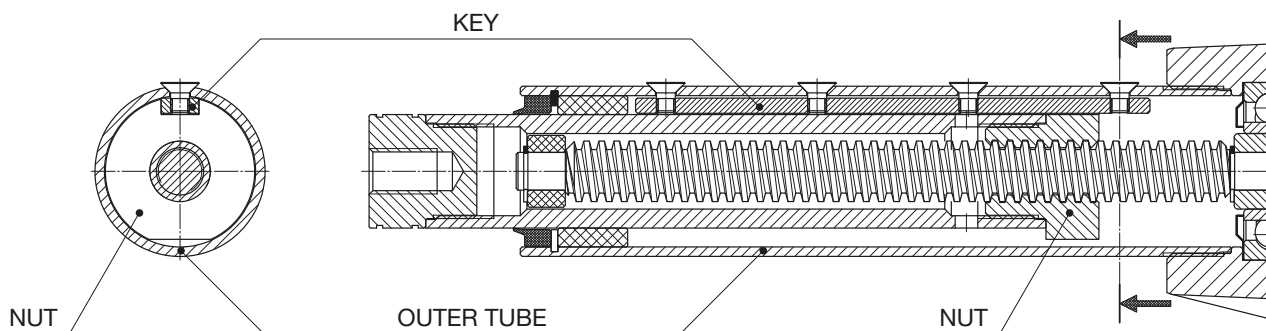

To achieve a linear motion it is necessary to prevent the rotary movement of the nut and of the push rod fixed to it. In many applications it is the external structure itself that, being connected to the push rod, prevents the rotation and allows the linear motion.

In some cases the load applied on the push rod cannot be guided and therefore the rotation cannot be avoided. In such cases it is necessary to use actuators with an internal anti-turn device. The ANTI-TURN device allows the linear motion without any external reaction on the push rod. It can be supplied upon request.

The anti-turn device shown in the above picture consists in a steel key fixed and aligned along the outer tube. The bronze nut, provided with a suitable keyway, slides on this key, making translate the push rod.

The ANTI-TURN device AR is available for linear actuators UAL 2, UAL 3, UAL 4 **without MAGNETIC STROKE END SWITCHES FCM** and UAL 5. **It is not available** for actuators UAL 1 and for all ball screw linear actuators (UBA Series).

SAFETY NUT Code MS

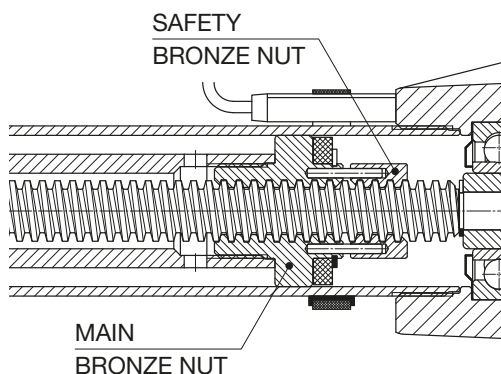

The SAFETY NUT is an auxiliary bronze nut connected by 2 pins to the main bronze nut. The distance between the two nuts in a new actuator is equal to a half of the thread pitch. If the main nut wears up to a half of the thread pitch or crashes, the SAFETY NUT supports the load avoiding its fall.

The SAFETY NUT is a one-direction device. Its position with respect to the main nut depends on the load direction. The SAFETY NUT is available for actuators working with push load. For applications with pull load a special design is available (contact SERVOMECH).

The SAFETY NUT MS is available for acme screw actuators UAL 2, UAL 3, UAL 4 and UAL 5.

4

Linear actuators UBA Series and UAL Series

4.5 ACCESSORIES

PROTECTIVE BELLOWS Code B

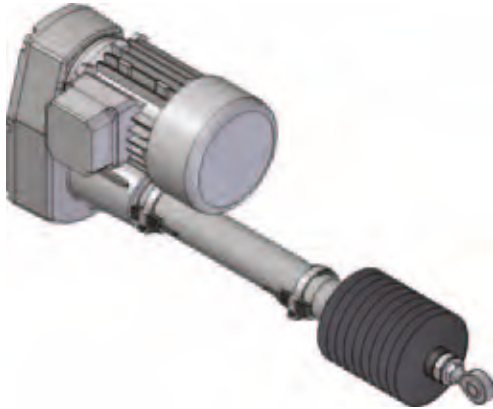

When the actuators are used in particular environment conditions with contaminant agents that can damage the seal scraper between the outer tube and the push rod, BELLOWS protection can be useful.

Bellows made of special materials for hard environments are available upon request.

ROTARY ENCODER

For the positioning control of all linear actuators ATL Series and BSA Series (all sizes), an incremental rotary encoders can be supplied, fixed to the housing, the side opposite to the motor, and connected to the motor shaft through an auxiliary shaft.

On request, the linear actuator can be equipped with an absolute rotary encoder.

ROTARY ENCODER Code EH 53

Optical encoder, incremental, bi-directional

Resolution: 100 or 500 pulses per revolution

Output: PUSH-PULL
2 channels (phase difference 90°)
channel ZERO

Input voltage: (8 ... 24) Vcc

No-load current: 100 mA

Max. commutable current: 50 mA

Cable length: 0.5 m

Protection: IP 54

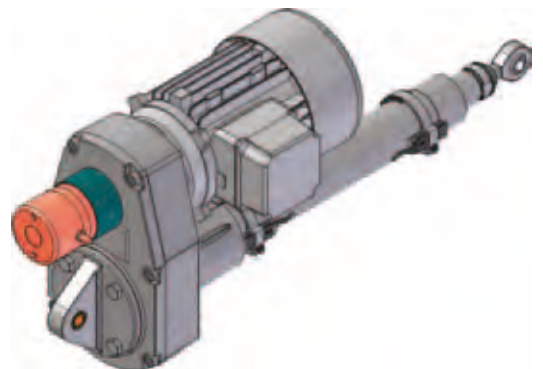

(On request, in case of linear actuators with DC motor, the motor can be supplied with a tacho-generator mounted on the opposite side of the motor shaft.)

4.6 SPECIAL DESIGNS

According to specific application requirements, special designs can be carried out on standard actuators.

Some possible options are for example:

- push rod in stainless steel AISI 304
- outer tube in stainless steel AISI 304
- lubricants for high or low ambient temperature
- lubricants suitable for food industry
- seals in VITON or silicone
- wiper seal on push rod with second lip in brass (ice scrapers)

Thanks to the long experience and know-how, SERVOMECH is able to support customers in selecting the right actuator version and accessories suitable for specific environment and installation conditions.

Linear actuators UBA Series and UAL Series

4.6 ORDERING CODE

UBA	4	RN2	C300	FO	—	FCM
1	2	3	4	5	6	7

SP encoder ...	8
----------------	---

AC 3-phase brake-motor 0.75 kW 4-pole 230/400 V 50 Hz IP 55 Ins. F	W
9.A	9.B

1	Actuator series UBA or UAL	
2	Actuator size 1, 2, 3, 4, 5	pages 128 ... 129
3	Ratio RV1, RN1, RL1 RV2, RN2, RL2	pages 128 ... 129
4	Stroke code C100, C200, C300, C400, C500, C600, C700, C800 (special stroke available on request)	
5	Front attachment BA - standard head with threaded bore ROE - rod end FO - clevis end TS - ball joint FL - flange end TF - hinged head	pages 136 ... 145
6	Position of front and rear actuator attachment STANDARD (without code) or RPT 90°	page 146
7	Stroke end switches FCM-NC - magnetic reed switches, normally closed FCM-NO - magnetic reed switches normally open FCP - inductive proximity switches	pages 147 ... 148 pages 147 ... 148 page 149
8	Accessories SP - rear bracket FI - intermediate support flange AR - anti-turn device MS - safety nut for push load B - bellows encoder - EH 53 or according to required specifications	pages 136 ... 145 page 146 page 150 page 150 page 151 page 151
9.A	Motor data	pages 200 ... 201
9.B	Motor terminal box position	page 146
10	Other specifications example: push rod in stainless steel AISI 303 example: lubricant for low temperature	
11	Filled in SELECTION DATA sheet	page 147
12	Application layout	

APPLICATION: _____

REQUIRED STROKE: _____ mm

REQUIRED LINEAR SPEED: _____ mm/s _____ mm/min _____ m/min TIME TO PERFORM 1 STROKE: _____ s

STATIC LOAD: PULL: _____ N PUSH: _____ N at STROKE _____ mm

DYNAMIC LOAD: PULL: _____ N PUSH: _____ N at STROKE _____ mm

ACTUATOR SUBJECTED TO VIBRATIONS NOT SUBJECTED TO VIBRATIONS

OPERATING: _____ cycle / hour _____ working hours / day Notes: _____

REQUIRED LIFETIME: _____ cycle _____ hours _____ calendar days Notes: _____

ENVIRONMENT: TEMPERATURE _____ °C DUST HUMIDITY _____ % AGGRESSIVE AGENT _____

Ball screw actuators **UBA Series** Acme screw actuators **UAL Series**

Size: 1 2 3 4 5

Ratio: RV2 RV1 RN2 RN1 RL2 RL1

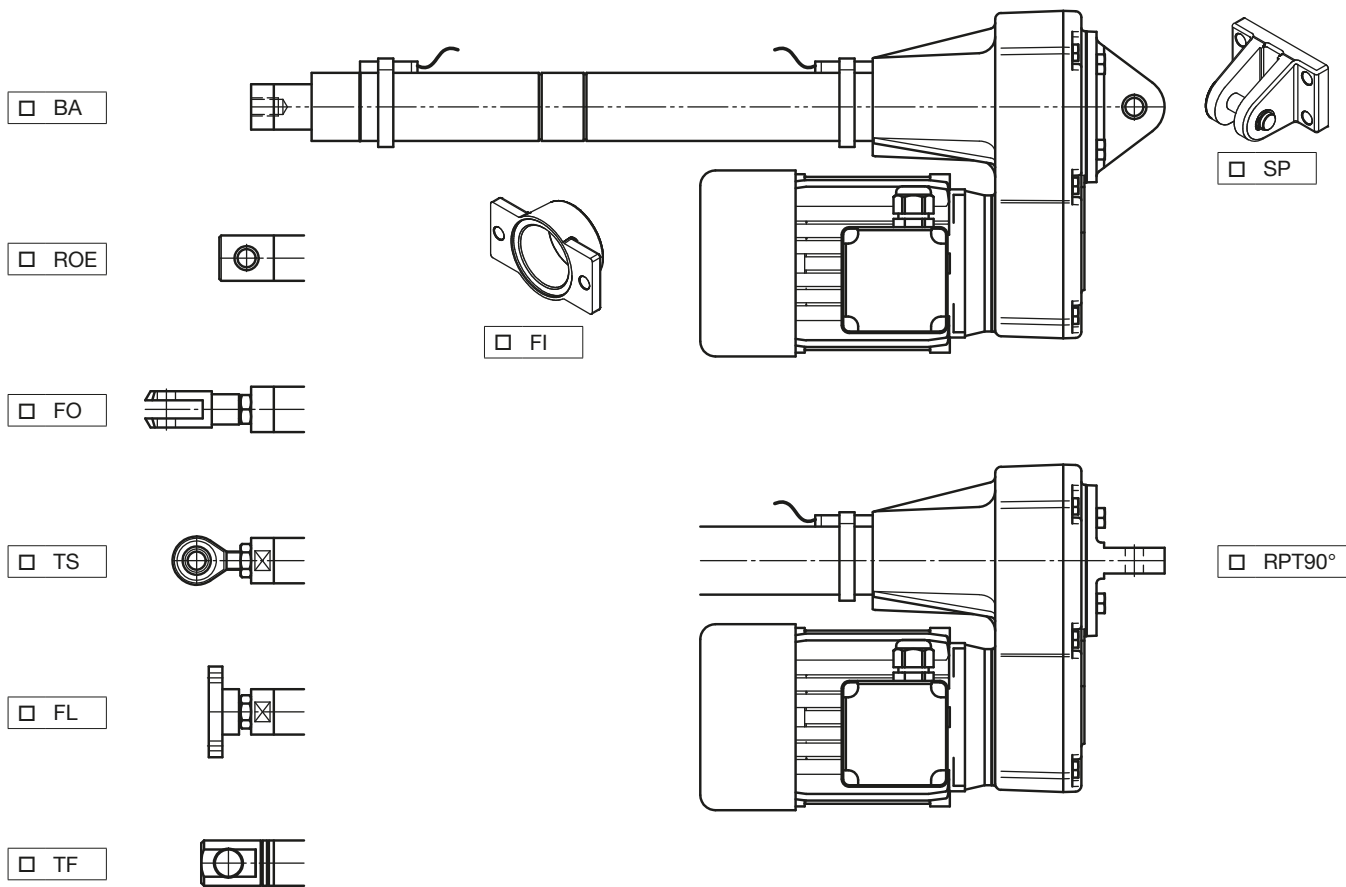

ELECTRIC MOTOR AC 3-phase AC 1-phase DC 24 V or 12 V WITHOUT BRAKE WITH BRAKE

STROKE END SWITCHES ELECTRIC FCE MAGNETIC FCM PROXIMITY FCP

ROTARY ENCODER

ANTI-TURN DEVICE AR SAFETY NUT MS

BELLOWS PUSH ROD IN STAINLESS STEEL OUTER TUBE IN STAINLESS STEEL

OTHER: _____

Ball screw actuators **UBA Series**

Acme screw actuators **UAL Series**

PRODUCT: _____

Product serial number: _____ ; q.ty: _____

STANDARD HEAD

BA

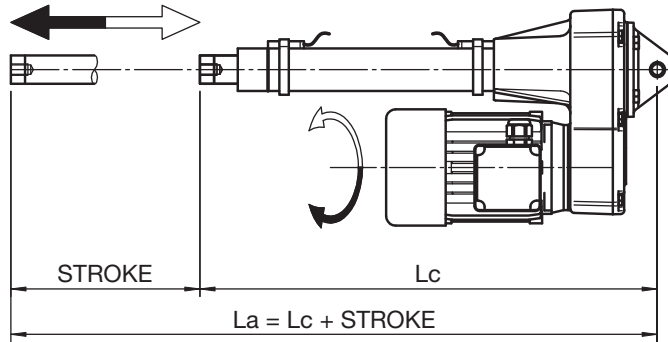

ELECTRIC MOTOR

- AC 3-phase
- AC 1-phase
- DC

- WITHOUT brake
- WITH brake
 - internally powered
 - separately powered

CLEVIS END

FO

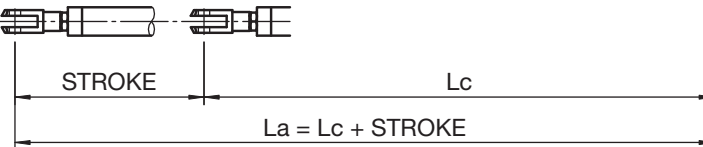

BALL JOINT

TS

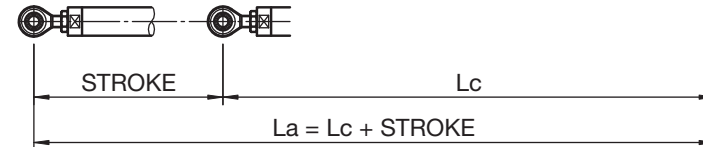

FLANGE END

FL

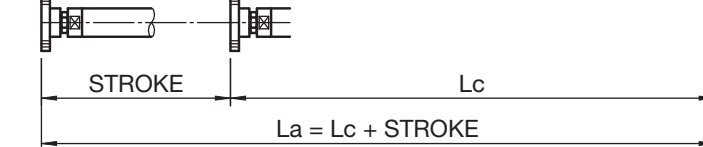

ROD END

ROE

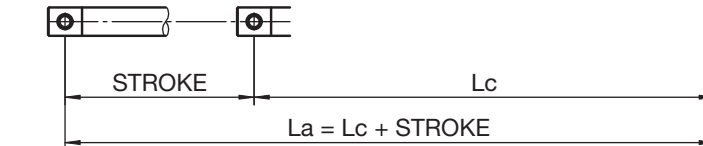

HINGED HEAD

TF

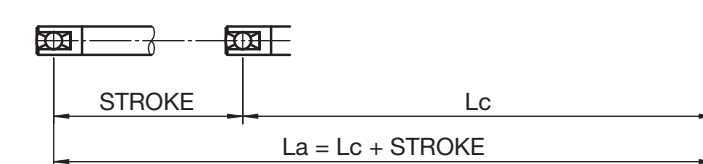

Servomech. QMS

PASSED

Date: _____

Signature: _____

LINEAR ACTUATOR LENGTH (ref. to BA ROE TF FL)

WORKING RANGE

INTERNAL MECHANICAL STOP LIMIT

RETRACTED ACTUATOR length:	Lc = _____ mm	MIN. actuator length:	_____ mm
EXTENDED ACTUATOR length:	La = _____ mm	MAX. actuator length:	_____ mm
STROKE (La - Lc):	C = _____ mm		

MAGNETIC STROKE END SWITCHES **FCM** □

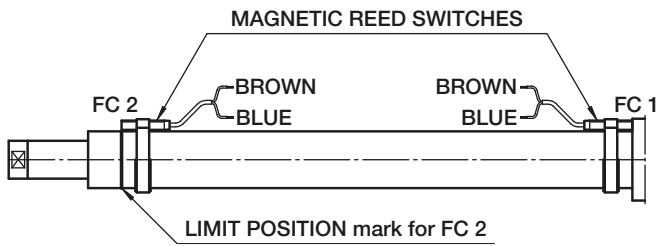

The MAGNETIC STROKE END SWITCHES **FCM** has reed switches FC 1 and FC 2.
 The rated electric values are indicated on the reed switch.
 The RETRACTED ACTUATOR position is adjusted and controlled by FC 1.
 The EXTENDED ACTUATOR position is adjusted and controlled by FC 2.
 Reed switch wires are BROWN and BLUE
 (and the third, BLACK, for change-over contact).
 For DC supply: connect the BROWN wire to ⊕.

PROXIMITY STROKE END SWITCHES **FCP** □

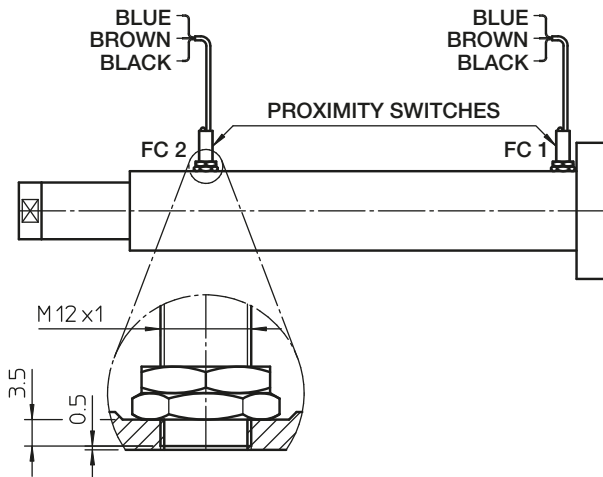

The PROXIMITY STROKE END SWITCHES **FCP** has proximity sensors FC 1 and FC 2.

- type: inductive, PNP
- contact: **normally CLOSED**
- supply voltage: (10 ... 30) V DC
- max. output current: 200 mA
- max. voltage drop (activated sensor): < 3 V (ref. 200 mA)

FC 1 - sensor for RETRACTED ACTUATOR position
 FC 2 - sensor for EXTENDED ACTUATOR position

SINGLE SENSOR WIRING:

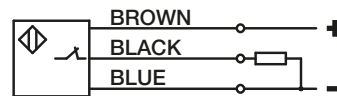

WARNING!

1. The values **Lc** (RETRACTED ACTUATOR length), **La** (EXTENDED ACTUATOR length) and **C** (STROKE) are the extreme limit values.
2. **BEFORE** using the linear actuator:
 - verify the input shaft rotating direction and the push rod running direction;
 - check the stroke end switches position: they must not exceed the extreme limit positions;
 - make sure that the motor and the limit switches are correctly connected and that the right voltage is used.
3. Linear actuators equipped with brake motor:
 - the brake is **NORMALLY CLOSED** (NEGATIVE action). When the power supply is switched off, the brake is engaged. The brake opens only when power is supplied;
 - if the brake is wired directly to the connecting pins of the terminal box, it does not require any power supply;
 - if the brake is wired separately, make sure that the correct voltage is used;
 - if the brake is equipped with hand release device, make sure that the brake is engaged before starting the linear actuator.
4. **Alignment check:** the load must be in line with the actuator. No off-set or radial loads are allowed.

NOTE: _____

WORMGEAR LUBRICANT: _____

SCREW – NUT LUBRICANT: _____

Linear actuators TMA Series

Linear Actuators TMA Series
rear attachment with bushes

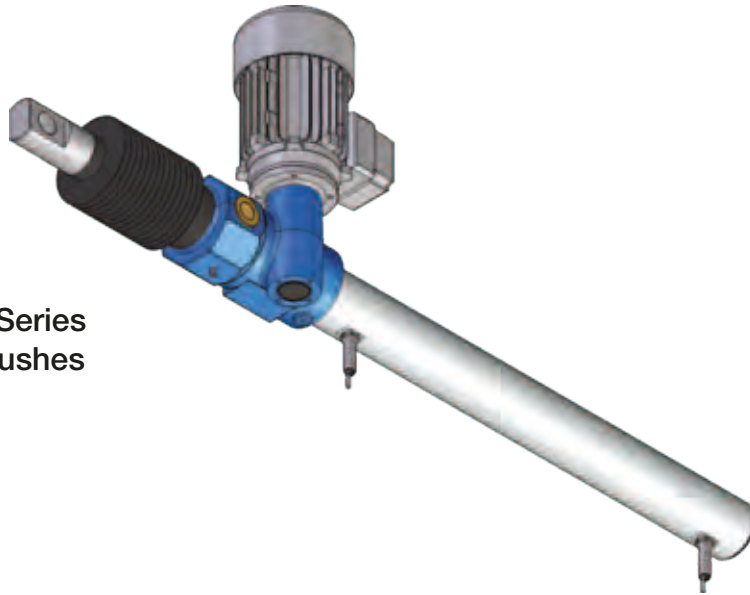

Linear Actuators TMA Series
rear attachment with pins

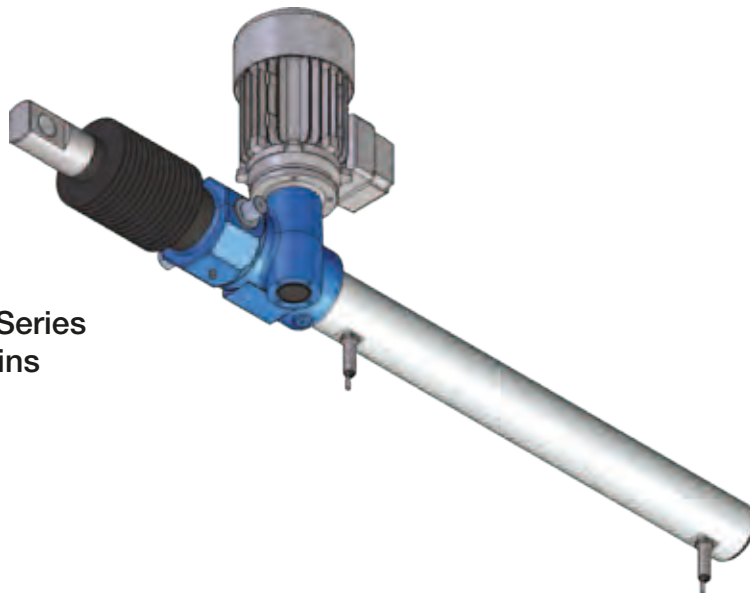

Example of system
with 2 linear actuators TMA Series
and only one electric motor

5

Linear actuators TMA Series

5.1 MANUFACTURING FEATURES

Housing:

designed and manufactured in monobloc form to achieve a compact body able to sustain heavy axial loads and have a high rigidity.

Material: grey cast iron EN-GJL-250 (UNI EN 1561)

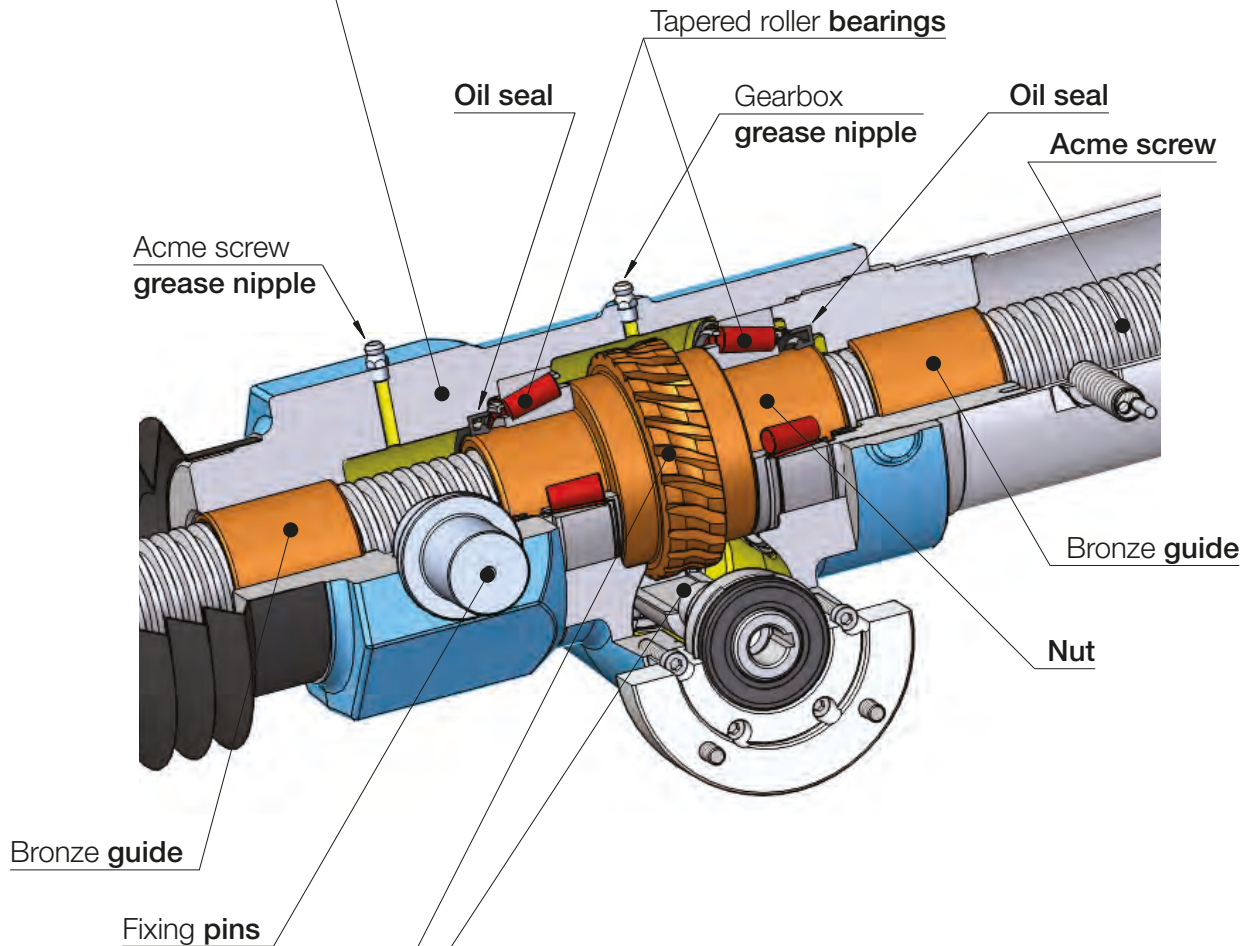

Input drive:

precision worm gear

geometric design for high efficiency,

involute profile ZI (UNI 4760 Part 4), low angular backlash.

Worm shaft in case hardened steel 20 MnCr 5 (UNI EN 10084), with thread and input shafts ground.

Wormwheel in bronze EN 1982 – CuSn12-C.

Linear actuators TMA Series

5.2 TECHNICAL DATA - acme screw linear actuators TMA Series

SIZE		TMA 15	TMA 25	TMA 50
Load capacity [kN], (push - pull)		15	25	50
1-start acme screw		Tr 22x5	Tr 30x6	Tr 40x7
Input solid shaft diameter [mm]		10	14	19
Attachment for IEC standard motor (flange and hollow shaft)		63 B14	63 B14	71 B14
Attachment for IEC standard motor (flange adapter + coupling)		—	71 B14	80 B14 90 B14
Ratio	RV	1 : 4 (4 : 16)	1 : 5 (4 : 20)	1 : 6 (4 : 24)
	RN	1 : 16 (2 : 32)	1 : 20	1 : 18 (2 : 36)
	RL	1 : 24	1 : 25	1 : 24
	RXL	1 : 34	1 : 48	1 : 44
Linear travel [mm] for 1 input shaft revolution	Ratio			
	RV1	1.25	1.2	1.17
	RN1	0.31	0.3	0.33
	RL1	0.21	0.24	0.29
Starting efficiency	Ratio			
	RV1	0.26	0.24	0.21
	RN1	0.20	0.16	0.16
	RL1	0.16	0.15	0.14
Running efficiency at 1500 rpm	Ratio			
	RV1	0.41	0.40	0.37
	RN1	0.31	0.27	0.28
	RL1	0.27	0.26	0.25
Starting torque on input shaft at max. load [Nm]	Ratio			
	RV1	12	20	44
	RN1	3.7	7.5	19
	RL1	3.1	6.3	17
RXL1	2.8	4.7	12	
Reaction torque on acme screw at max. load [Nm]		30	65	165
Mass of actuator without acme screw [kg]		8	13	26
Mass of each 100 mm of acme screw [kg]		0.5	0.8	1.5

Linear actuators TMA Series

5.2 TECHNICAL DATA - acme screw linear actuators TMA Series

TMA 100	TMA 150	TMA 200	SIZE
100	150	200	Load capacity [kN], (push - pull)
Tr 55×9	Tr 60×12	Tr 80×12	1-start acme screw
24	24	28	Input solid shaft diameter [mm]
80 B5	80 B5	90 B5	Attachment for IEC standard motor (flange and hollow shaft)
90 B14 100-112 B14	90 B14 100-112 B14	100-112 B14	Attachment for IEC standard motor (flange adapter + coupling)
1 : 7 (4 : 28)	1 : 7 (4 : 28)	1 : 8 (4 : 32)	RV
1 : 14 (2 : 28)	1 : 14 (2 : 28)	1 : 24	RN
1 : 28	1 : 28	1 : 32	RL
1 : 40	1 : 40	—	RXL
1.29	1.71	1.5	RV1
0.64	0.86	0.5	RN1
0.32	0.43	0.38	RL1
0.23	0.3	—	RXL1
0.20	0.24	0.21	RV1
0.17	0.20	0.14	RN1
0.13	0.15	0.13	RL1
0.12	0.14	—	RXL1
0.37	0.42	0.39	RV1
0.32	0.36	0.29	RN1
0.25	0.29	0.27	RL1
0.22	0.26	—	RXL1
102	174	230	RV1
61	105	110	RN1
40	70	91	RL1
30	53	—	RXL1
460	800	1 200	Reaction torque on acme screw at max. load [Nm]
43	70	141	Mass of actuator without acme screw [kg]
2.5	3	10.5	Mass of each 100 mm of acme screw [kg]

Linear actuators TMA Series

5.3 PERFORMANCE (actuator WITHOUT input gearbox)

ACME SCREW LINEAR ACTUATORS TMA Series with AC 3-PHASE MOTOR
 PERFORMANCE with: Duty Cycle $F_i = 30\%$ over 10 min at ambient temperature 25 °C

LINEAR SPEED [mm/s]	DYNAMIC LOAD [kN]	RATIO	MOTOR: POWER [kW] – N° of POLES SPEED [rpm]	SELF-LOCKING COEFFICIENT
TMA 15				
29	2.6 ¹⁾	RV1	0.18 kW 4-pole 1400	0.26
7.3	7.7 ¹⁾	RN1	0.18 kW 4-pole 1400	0.20
4.9	10 ¹⁾	RL1	0.18 kW 4-pole 1400	0.16
3.4	12.2 ¹⁾	RXL1	0.18 kW 4-pole 1400	0.13
TMA 25				
28	5.4 ¹⁾	RV1	0.37 kW 4-pole 1400	0.24
7	14.4 ¹⁾	RN1	0.37 kW 4-pole 1400	0.16
5.6	17.5 ¹⁾	RL1	0.37 kW 4-pole 1400	0.15
2.9	25 ²⁾	RXL1	0.37 kW 4-pole 1400	0.11
TMA 50				
27	20.6 ¹⁾	RV1	1.5 kW 4-pole 1400	0.21
9	46.8 ¹⁾	RN1	1.5 kW 4-pole 1400	0.16
6.8	50 ²⁾	RL1	1.5 kW 4-pole 1400	0.14
3.7	50 ²⁾	RXL1	1.5 kW 4-pole 1400	0.11
TMA 100				
30	37.2 ¹⁾	RV1	3 kW 4-pole 1400	0.20
15	63 ¹⁾	RN1	3 kW 4-pole 1400	0.17
7.5	100 ²⁾	RL1	3 kW 4-pole 1400	0.13
5.3	100 ²⁾	RXL1	3 kW 4-pole 1400	0.12
TMA 150				
40	42 ¹⁾	RV1	4 kW 4-pole 1400	0.24
20	72 ¹⁾	RN1	4 kW 4-pole 1400	0.20
10	115 ¹⁾	RL1	4 kW 4-pole 1400	0.15
7	147 ¹⁾	RXL1	4 kW 4-pole 1400	0.14
TMA 200				
35	58 ¹⁾	RV1	5.2 kW 4-pole 1400	0.21
12	130 ¹⁾	RN1	5.2 kW 4-pole 1400	0.14
8.8	159 ¹⁾	RL1	5.2 kW 4-pole 1400	0.13

Note: Lower linear speeds are achievable with 3-phase 6-pole electric motors.

¹⁾ value limited by electric motor power

The total dynamic efficiency (η) of TMA Series actuators **without input drive**, used to determine the DYNAMIC LOAD is calculated as follows:

$$\eta = \eta_1 \times \eta_2 \times \eta_3$$

where:

η_1 – wormgear dynamic efficiency, calculated according to BS 721 : Part 2 : 1983

η_2 – acme screw-bronze nut dynamic efficiency, calculated with reference to the speed

$\eta_3 = 0.9$ – bearings and sealing elements “efficiency”

²⁾ value limited by linear actuator load capacity (see pages 158 ... 159)

Linear actuators TMA Series

5.3 PERFORMANCE (actuator WITH input gearbox)

ACME SCREW LINEAR ACTUATORS TMA Series with AC 3-PHASE MOTOR
PERFORMANCE with: Duty Cycle $F_i = 30\%$ over 10 min at ambient temperature 25 °C

LINEAR SPEED [mm/s]	DYNAMIC LOAD [kN]	ACTUATOR: RATIO	INPUT GEARBOX: CENTRE DISTANCE RATIO	MOTOR: POWER [kW] – N° of POLES SPEED [rpm]	SELF-LOCKING COEFFICIENT
TMA 15					
2.3	9 ¹⁾	RN1	1 25 R 6.25	0.12 kW 2-pole 2800	0.14
1.2	15 ²⁾	RN1	1 25 R 12.5	0.12 kW 2-pole 2800	0.14
0.39	15 ²⁾	RL1	1 25 R 12.5	0.09 kW 4-pole 1400	0.10
0.14	15 ²⁾	RXL1	1 25 R 25	0.09 kW 4-pole 1400	0.06
TMA 25					
1.8	20 ¹⁾	RN1	1 30 R 4	0.18 kW 4-pole 1400	0.09
0.88	25 ²⁾	RN1	1 30 R 16	0.25 kW 2-pole 2800	0.09
0.45	25 ²⁾	RL1	1 25 R 12.5	0.09 kW 4-pole 1400	0.10
0.12	25 ²⁾	RXL1	1 25 R 25	0.09 kW 4-pole 1400	0.05
TMA 50					
1.8	39 ¹⁾	RN1	1 40 R 5	0.37 kW 4-pole 1400	0.10
0.91	50 ²⁾	RN1	1 40 R 20	0.55 kW 2-pole 2800	0.08
0.43	50 ²⁾	RL1	1 30 R 16	0.18 kW 4-pole 1400	0.08
0.15	50 ²⁾	RXL1	1 30 R 24	0.18 kW 4-pole 1400	0.05
TMA 100					
2	100 ²⁾	RV1	1 63 R 15	1.1 kW 4-pole 1400	0.14
1	100 ²⁾	RN1	1 50 R 15	0.75 kW 4-pole 1400	0.12
0.38	100 ²⁾	RL1	1 40 R 20	0.37 kW 4-pole 1400	0.07
0.21	100 ²⁾	RXL1	1 40 R 25	0.37 kW 4-pole 1400	0.06
TMA 150					
2	117 ¹⁾	RV1	1 63 R 20	1.1 kW 4-pole 1400	0.14
1	150 ²⁾	RN1	1 50 R 20	1.1 kW 4-pole 1400	0.12
0.5	150 ²⁾	RL1	1 50 R 20	0.75 kW 4-pole 1400	0.09
0.13	150 ²⁾	RXL1	1 40 R 55	0.37 kW 4-pole 1400	0.01
TMA 200					
1.8	162 ¹⁾	RV1	1 63 R 20	1.5 kW 4-pole 1400	0.13
0.78	200 ²⁾	RN1	1 50 R 15	1.1 kW 4-pole 1400	0.10
0.13	200 ²⁾	RL1	1 63 R 70	0.75 kW 4-pole 1400	0.05

1) value limited by electric motor power

The total dynamic efficiency (η) of TMA Series actuators **with input drive**, used to determine the DYNAMIC LOAD is calculated as follows:

$$\eta = \eta_1 \times \eta_2 \times \eta_3 \times \eta_4$$

where:

η_1 – input drive wormgear dynamic efficiency, calculated according to BS 721 : Part 2 : 1983

η_2 – actuator wormgear dynamic efficiency, calculated according to BS 721 : Part 2 : 1983

η_3 – acme screw-bronze nut dynamic efficiency, calculated with reference to the speed

$\eta_4 = 0.85$ – bearings and sealing elements "efficiency"

2) value limited by linear actuator load capacity (see pages 158 ... 159)

Linear actuators TMA Series

5.4 CONFIGURATION

	DESCRIPTION	CONFIGURATION CODE
	<p>Rear attachment: BUSHES</p> <p>Input shaft axis PERPENDICULAR to the median plane , determined by the rear attachment axis and by the front attachment axis </p> <p>Rear attachment axis between input shaft axis and front attachment axis </p>	Config.1
	<p>Rear attachment: PINS</p> <p>Input shaft axis PERPENDICULAR to the median plane , determined by the rear attachment axis and by the front attachment axis </p> <p>Rear attachment axis between input shaft axis and front attachment axis </p>	Config.2
	<p>Rear attachment: BUSHES</p> <p>Input shaft axis PARALLEL to rear attachment axis and front attachment axis </p> <p>Rear attachment axis between input shaft axis and front attachment axis </p>	Config.3
	<p>Rear attachment: PINS</p> <p>Input shaft axis PARALLEL to rear attachment axis and front attachment axis </p> <p>Rear attachment axis between input shaft axis and front attachment axis </p>	Config.4

5

Linear actuators TMA Series



5.4 CONFIGURATION

	DESCRIPTION	CONFIGURATION CODE
	<p>Rear attachment: BUSHES</p> <p>Input shaft axis PERPENDICULAR to the median plane , determined by the rear attachment axis and by the front attachment axis </p> <p>Input shaft axis between rear attachment axis and front attachment axis </p>	Config.5
	<p>Rear attachment: PINS</p> <p>Input shaft axis PERPENDICULAR to the median plane , determined by the rear attachment axis and by the front attachment axis </p> <p>Input shaft axis between rear attachment axis and front attachment axis </p>	Config.6
	<p>Rear attachment: BUSHES</p> <p>Input shaft axis PARALLEL to rear attachment axis and front attachment axis </p> <p>Input shaft axis between rear attachment axis and front attachment axis </p>	Config.7
	<p>Rear attachment: PINS</p> <p>Input shaft axis PARALLEL to rear attachment axis and front attachment axis </p> <p>Input shaft axis between rear attachment axis and front attachment axis </p>	Config.8

Linear actuators TMA Series

5.5 OVERALL DIMENSIONS - actuator WITHOUT input gearbox

Input shaft axis perpendicular to front and rear attachments axis

Configurations with rear attachment axis  between input shaft axis  and front attachment axis 

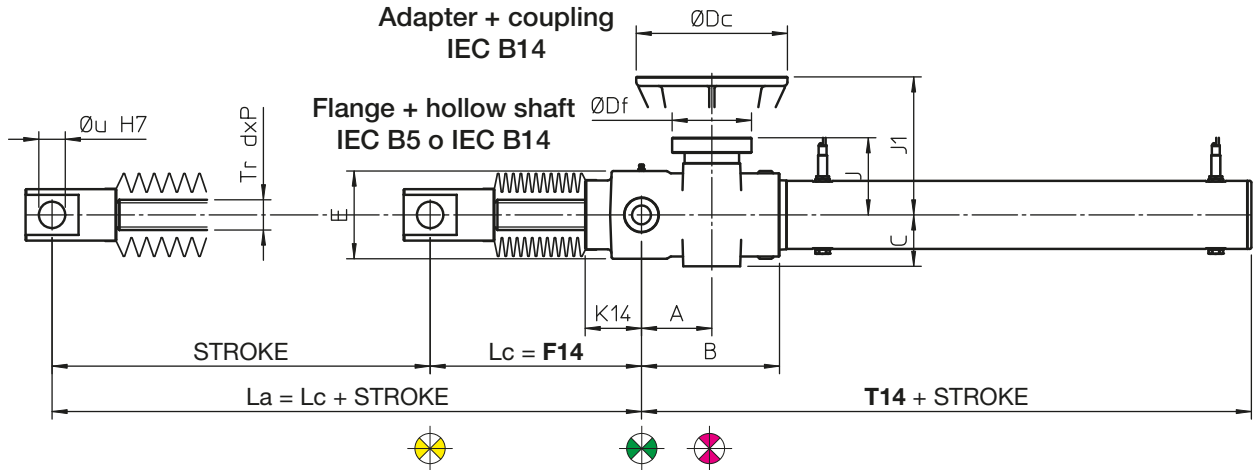

Lc - RETRACTED ACTUATOR length
La - EXTENDED ACTUATOR length

Front attachment
HINGED HEAD
TF

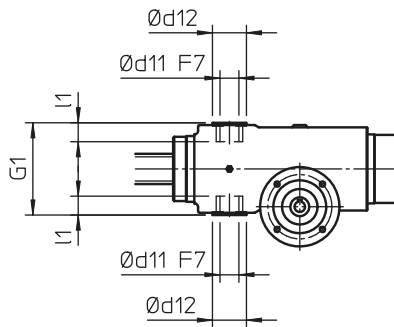
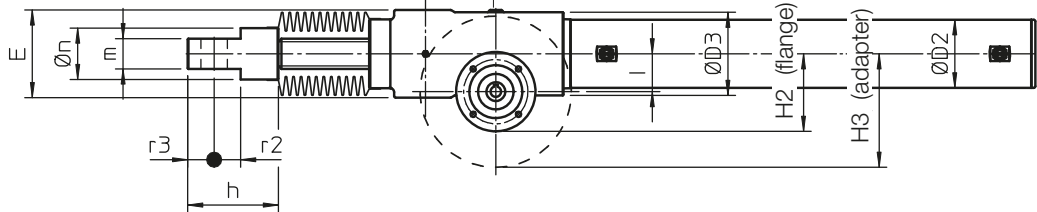

Rear attachment
BUSHES
Config.1

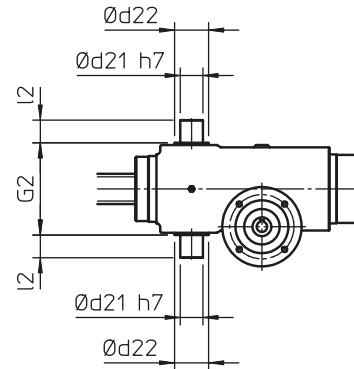

Rear attachment
PINS
Config.2

Front attachment
BALL JOINT
TS

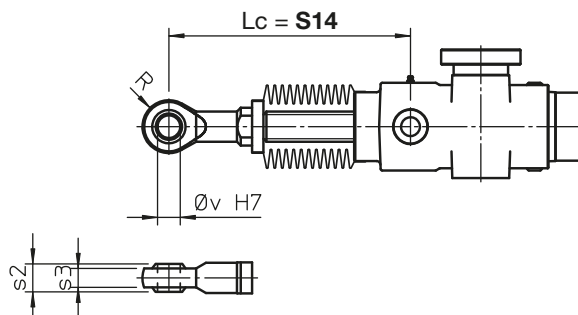

Linear actuators TMA Series

5.5 OVERALL DIMENSIONS - actuator WITHOUT input gearbox

Input shaft axis perpendicular to front and rear attachments axis

Config.1 and Config.2 - rear attachment axis between input shaft axis and front attachment axis

	Tr d×P	F14			S14			T14
TMA 15	Tr 22×5	125 ¹⁾	225 ²⁾	325 ³⁾	144 ¹⁾	244 ²⁾	344 ³⁾	240
TMA 25	Tr 30×6	156 ¹⁾	256 ²⁾	356 ³⁾	172 ¹⁾	272 ²⁾	372 ³⁾	259
TMA 50	Tr 40×7	180 ¹⁾	280 ²⁾	380 ³⁾	220 ¹⁾	320 ²⁾	420 ³⁾	304
TMA 100	Tr 55×9	197 ¹⁾	297 ²⁾	397 ³⁾	254 ¹⁾	354 ²⁾	454 ³⁾	332
TMA 150	Tr 60×12	254 ¹⁾	354 ²⁾	454 ³⁾	304 ¹⁾	404 ²⁾	504 ³⁾	404
TMA 200	Tr 80×12	276 ¹⁾	376 ²⁾	476 ³⁾	321 ¹⁾	421 ²⁾	521 ³⁾	525

1) without bellows

2) with bellows and STROKE < 600

3) with bellows and 600 < STROKE < 1200

4) with bellows and STROKE > 1200: please, contact SERVOMECH

	A	B	C	∅ D2	∅ D3	E	I	K14
TMA 15	67	132	50	50	82	88	30	50
TMA 25	77.5	145	57	65	90	96	40	61
TMA 50	93	183	68	90	110	116	50	75
TMA 100	110	219	83	110	140	150	63	77
TMA 150	140	248	83	130	153	168	63	104
TMA 200	200	340	103	160	200	240	80	106

	Attachment for IEC motor (flange + hollow shaft)				Attachment for IEC motor (adapter + coupling)			
	Size	∅ Df	H2	J	Size	∅ Dc	H3	J1
TMA 15	63 B14 – 63 B5	90 – 140	75 – 100	62	—	—	—	—
TMA 25	63 B14 – 63 B5	90 – 140	80 – 110	69	71 B14	105	93	138
TMA 50	63 B5	140	120	102	80 B14	120	110	182
	71 B14 – 71 B5	105 – 160	103 – 130	102	90 B14	140	120	182
TMA 100	80 B5	200	163	100	90 B14	140	133	200
					100 B14	160	143	220
TMA 150	80 B5	200	163	100	90 B14	140	133	200
					100 B14	160	143	220
TMA 200	80 B5	200	179	119	100 B14	160	159	240
	90 B5				112 B14			

	G1	G2	∅ d11	∅ d12	∅ d21	∅ d22	l1	l2
TMA 15	91	92	16	28	16	28	22	16
TMA 25	100	100	20	35	20	35	20	20
TMA 50	122	122	25	45	30	45	25	30
TMA 100	154	154	35	55	40	55	35	40
TMA 150	176	176	40	60	40	60	40	40
TMA 200	248	248	50	70	50	70	60	50

	h	m	∅ n	R	r2	r3	s2	s3	∅ u	∅ v
TMA 15	75	25	38	21	20	20	21	15.5	20	16
TMA 25	100	30	48	27	25	25	16	13	25	20
TMA 50	120	40	68	37	35	35	22	19	35	30
TMA 100	140	50	78	46	40	40	28	23	40	40
TMA 150	180	60	90	56	50	50	35	30	50	50
TMA 200	210	75	108	68	60	60	44	38	60	60

5

Linear actuators TMA Series

5.5 OVERALL DIMENSIONS - actuator WITHOUT input gearbox

Input shaft axis parallel to front and rear attachments axis

Configurations with rear attachment axis between input shaft axis and front attachment axis

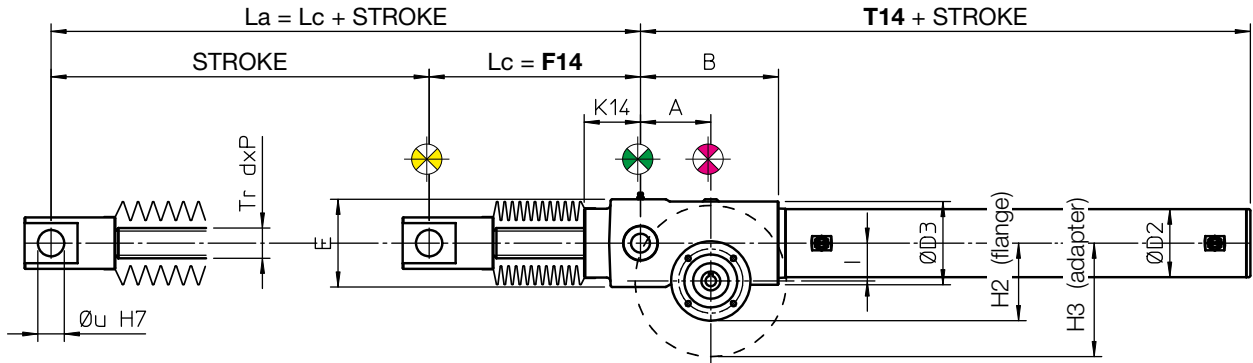

Lc - RETRACTED ACTUATOR length
La - EXTENDED ACTUATOR length

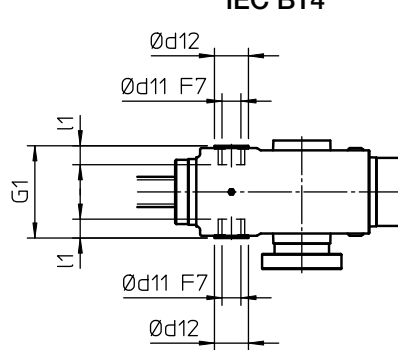
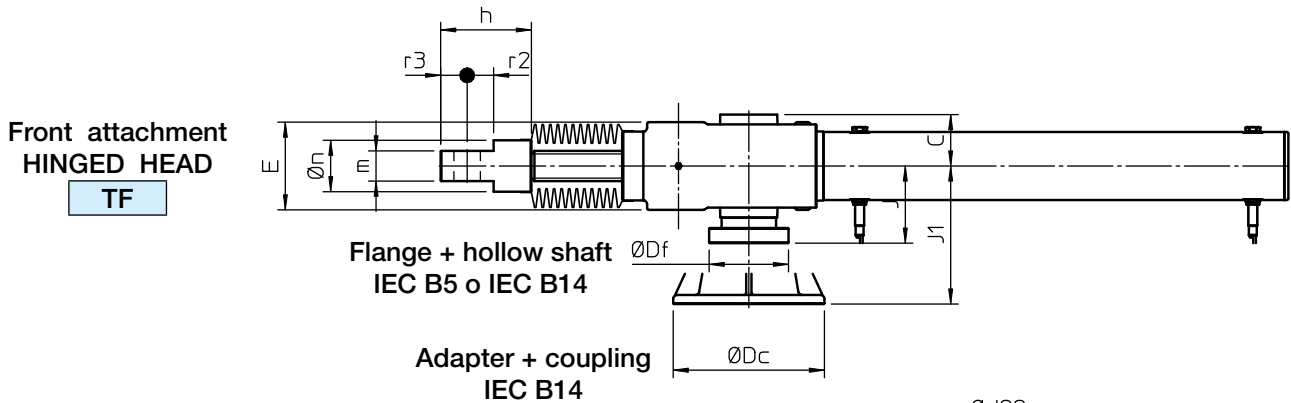

Rear attachment
BUSHES
Config.3

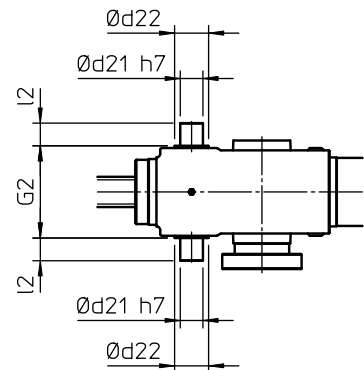

Rear attachment
PINS
Config.4

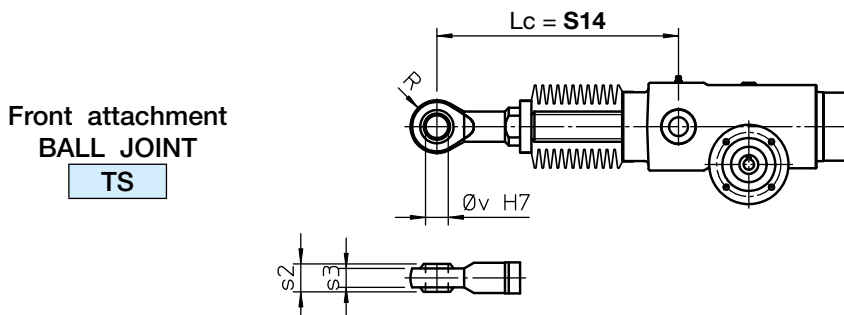

Linear actuators TMA Series

5.5 OVERALL DIMENSIONS - actuator WITHOUT input gearbox

Input shaft axis parallel to front and rear attachments axis

Config.3 and Config.4 - rear attachment axis between input shaft axis and front attachment axis

	Tr d×P	F14			S14			T14
TMA 15	Tr 22×5	125 ¹⁾	225 ²⁾	325 ³⁾	144 ¹⁾	244 ²⁾	344 ³⁾	240
TMA 25	Tr 30×6	156 ¹⁾	256 ²⁾	356 ³⁾	172 ¹⁾	272 ²⁾	372 ³⁾	259
TMA 50	Tr 40×7	180 ¹⁾	280 ²⁾	380 ³⁾	220 ¹⁾	320 ²⁾	420 ³⁾	304
TMA 100	Tr 55×9	197 ¹⁾	297 ²⁾	397 ³⁾	254 ¹⁾	354 ²⁾	454 ³⁾	332
TMA 150	Tr 60×12	254 ¹⁾	354 ²⁾	454 ³⁾	304 ¹⁾	404 ²⁾	504 ³⁾	404
TMA 200	Tr 80×12	276 ¹⁾	376 ²⁾	476 ³⁾	321 ¹⁾	421 ²⁾	521 ³⁾	525

1) without bellows

2) with bellows and STROKE < 600

3) with bellows and 600 < STROKE < 1200

4) with bellows and STROKE > 1200: please, contact SERVOMECH

	A	B	C	∅ D2	∅ D3	E	I	K14
TMA 15	67	132	50	50	82	88	30	50
TMA 25	77.5	145	57	65	90	96	40	61
TMA 50	93	183	68	90	110	116	50	75
TMA 100	110	219	83	110	140	150	63	77
TMA 150	140	248	83	130	153	168	63	104
TMA 200	200	340	103	160	200	240	80	106

	Attachment for IEC motor (flange + hollow shaft)				Attachment for IEC motor (adapter + coupling)			
	Size	∅ Df	H2	J	Size	∅ Dc	H3	J1
TMA 15	63 B14 – 63 B5	90 – 140	75 – 100	62	—	—	—	—
TMA 25	63 B14 – 63 B5	90 – 140	80 – 110	69	71 B14	105	93	138
TMA 50	63 B5	140	120	102	80 B14	120	110	182
	71 B14 – 71 B5	105 – 160	103 – 130	102	90 B14	140	120	182
TMA 100	80 B5	200	163	100	90 B14	140	133	200
					100 B14	160	143	220
TMA 150	80 B5	200	163	100	90 B14	140	133	200
					100 B14	160	143	220
TMA 200	80 B5	200	179	119	100 B14	160	159	240
	90 B5				112 B14			

	G1	G2	∅ d11	∅ d12	∅ d21	∅ d22	l1	l2
TMA 15	91	92	16	28	16	28	22	16
TMA 25	100	100	20	35	20	35	20	20
TMA 50	122	122	25	45	30	45	25	30
TMA 100	154	154	35	55	40	55	35	40
TMA 150	176	176	40	60	40	60	40	40
TMA 200	248	248	50	70	50	70	60	50

	h	m	∅ n	R	r2	r3	s2	s3	∅ u	∅ v
TMA 15	75	25	38	21	20	20	21	15.5	20	16
TMA 25	100	30	48	27	25	25	16	13	25	20
TMA 50	120	40	68	37	35	35	22	19	35	30
TMA 100	140	50	78	46	40	40	28	23	40	40
TMA 150	180	60	90	56	50	50	35	30	50	50
TMA 200	210	75	108	68	60	60	44	38	60	60

Linear actuators TMA Series

5.5 OVERALL DIMENSIONS - actuator WITHOUT input gearbox

Input shaft axis perpendicular to front and rear attachments axis

Config.5 and Config.6 - input shaft axis between rear attachment axis and front attachment axis

	Tr d×P	F58			S58			T58
TMA 15	Tr 22×5	235 ¹⁾	335 ²⁾	435 ³⁾	254 ¹⁾	354 ²⁾	454 ³⁾	130
TMA 25	Tr 30×6	274 ¹⁾	374 ²⁾	474 ³⁾	290 ¹⁾	390 ²⁾	490 ³⁾	140
TMA 50	Tr 40×7	324 ¹⁾	424 ²⁾	524 ³⁾	364 ¹⁾	464 ²⁾	564 ³⁾	160
TMA 100	Tr 55×9	367 ¹⁾	467 ²⁾	567 ³⁾	424 ¹⁾	524 ²⁾	624 ³⁾	162
TMA 150	Tr 60×12	460 ¹⁾	560 ²⁾	660 ³⁾	510 ¹⁾	610 ²⁾	710 ³⁾	199
TMA 200	Tr 80×12	590 ¹⁾	690 ²⁾	790 ³⁾	635 ¹⁾	735 ²⁾	835 ³⁾	211

¹⁾ without bellows

²⁾ with bellows and STROKE < 600

³⁾ with bellows and 600 < STROKE < 1200

⁴⁾ with bellows and STROKE > 1200: please, contact SERVOMECH

	A	B	C	∅ D2	∅ D3	E	I	K58
TMA 15	67	132	50	50	82	88	30	160
TMA 25	77.5	145	57	65	90	96	40	179
TMA 50	93	183	68	90	110	116	50	220
TMA 100	110	219	83	110	140	150	63	247
TMA 150	140	248	83	130	153	168	63	305
TMA 200	200	340	103	160	200	240	80	420

	Attachment for IEC motor (flange + hollow shaft)				Attachment for IEC motor (adapter + coupling)			
	Size	∅ Df	H2	J	Size	∅ Dc	H3	J1
TMA 15	63 B14 – 63 B5	90 – 140	75 – 100	62	—	—	—	—
TMA 25	63 B14 – 63 B5	90 – 140	80 – 110	69	71 B14	105	93	138
TMA 50	63 B5	140	120	102	80 B14	120	110	182
	71 B14 – 71 B5	105 – 160	103 – 130	102	90 B14	140	120	182
TMA 100	80 B5	200	163	100	90 B14	140	133	200
					100 B14	160	143	220
TMA 150	80 B5	200	163	100	90 B14	140	133	200
					100 B14	160	143	220
TMA 200	80 B5	200	179	119	100 B14	160	159	240
	90 B5				112 B14			



	G1	G2	∅ d11	∅ d12	∅ d21	∅ d22	l1	l2
TMA 15	91	92	16	28	16	28	22	16
TMA 25	100	100	20	35	20	35	20	20
TMA 50	122	122	25	45	30	45	25	30
TMA 100	154	154	35	55	40	55	35	40
TMA 150	176	176	40	60	40	60	40	40
TMA 200	248	248	50	70	50	70	60	50

	h	m	∅ n	R	r2	r3	s2	s3	∅ u	∅ v
TMA 15	75	25	38	21	20	20	21	15.5	20	16
TMA 25	100	30	48	27	25	25	16	13	25	20
TMA 50	120	40	68	37	35	35	22	19	35	30
TMA 100	140	50	78	46	40	40	28	23	40	40
TMA 150	180	60	90	56	50	50	35	30	50	50
TMA 200	210	75	108	68	60	60	44	38	60	60

Linear actuators TMA Series

5.5 OVERALL DIMENSIONS - actuator WITHOUT input gearbox

Input shaft axis parallel to front and rear attachments axis

Configurations with input shaft axis  between rear attachment axis  and front attachment axis 

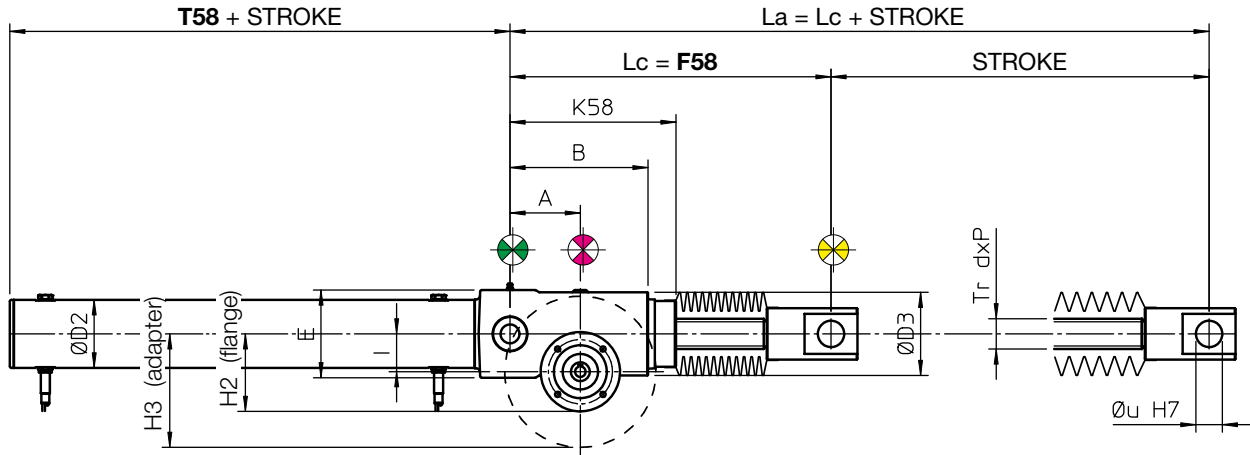

Lc - RETRACTED ACTUATOR length
La - EXTENDED ACTUATOR length

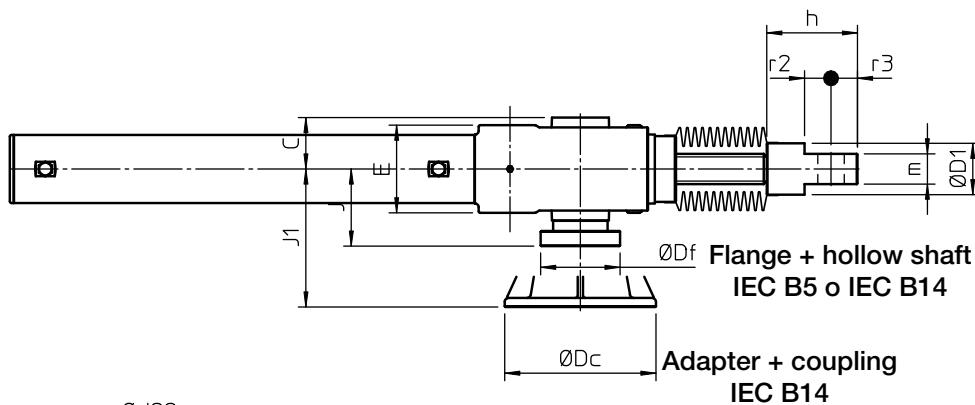

Front attachment
HINGED HEAD
TF

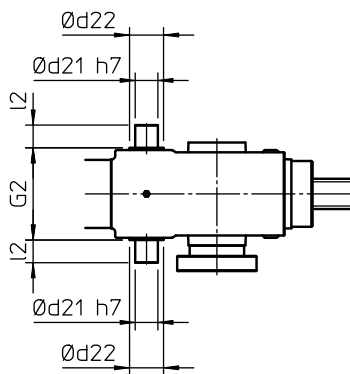

Rear attachment
PINS
Config.8

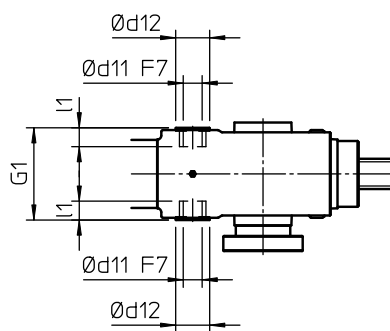

Rear attachment
BUSHES
Config.7

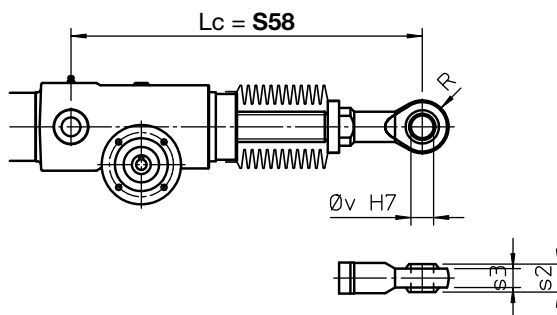

Front attachment
BALL JOINT
TS

5

Linear actuators TMA Series

5.5 OVERALL DIMENSIONS - actuator WITHOUT input gearbox

Input shaft axis parallel to front and rear attachments axis

Config.7 and Config.8 - input shaft axis between rear attachment axis and front attachment axis

	Tr d×P	F58			S58			T58
TMA 15	Tr 22×5	235 ¹⁾	335 ²⁾	435 ³⁾	254 ¹⁾	354 ²⁾	454 ³⁾	130
TMA 25	Tr 30×6	274 ¹⁾	374 ²⁾	474 ³⁾	290 ¹⁾	390 ²⁾	490 ³⁾	140
TMA 50	Tr 40×7	324 ¹⁾	424 ²⁾	524 ³⁾	364 ¹⁾	464 ²⁾	564 ³⁾	160
TMA 100	Tr 55×9	367 ¹⁾	467 ²⁾	567 ³⁾	424 ¹⁾	524 ²⁾	624 ³⁾	162
TMA 150	Tr 60×12	460 ¹⁾	560 ²⁾	660 ³⁾	510 ¹⁾	610 ²⁾	710 ³⁾	199
TMA 200	Tr 80×12	590 ¹⁾	690 ²⁾	790 ³⁾	635 ¹⁾	735 ²⁾	835 ³⁾	211

¹⁾ without bellows

²⁾ with bellows and STROKE < 600

³⁾ with bellows and 600 < STROKE < 1200

⁴⁾ with bellows and STROKE > 1200: please, contact SERVOMECH

	A	B	C	∅ D2	∅ D3	E	I	K58
TMA 15	67	132	50	50	82	88	30	160
TMA 25	77.5	145	57	65	90	96	40	179
TMA 50	93	183	68	90	110	116	50	220
TMA 100	110	219	83	110	140	150	63	247
TMA 150	140	248	83	130	153	168	63	305
TMA 200	200	340	103	160	200	240	80	420

	Attachment for IEC motor (flange + hollow shaft)				Attachment for IEC motor (adapter + coupling)			
	Size	∅ Df	H2	J	Size	∅ Dc	H3	J1
TMA 15	63 B14 – 63 B5	90 – 140	75 – 100	62	—	—	—	—
TMA 25	63 B14 – 63 B5	90 – 140	80 – 110	69	71 B14	105	93	138
TMA 50	63 B5	140	120	102	80 B14	120	110	182
	71 B14 – 71 B5	105 – 160	103 – 130	102	90 B14	140	120	182
TMA 100	80 B5	200	163	100	90 B14	140	133	200
					100 B14	160	143	220
TMA 150	80 B5	200	163	100	90 B14	140	133	200
					100 B14	160	143	220
TMA 200	80 B5	200	179	119	100 B14	160	159	240
	90 B5				112 B14			

	G1	G2	∅ d11	∅ d12	∅ d21	∅ d22	l1	l2
TMA 15	91	92	16	28	16	28	22	16
TMA 25	100	100	20	35	20	35	20	20
TMA 50	122	122	25	45	30	45	25	30
TMA 100	154	154	35	55	40	55	35	40
TMA 150	176	176	40	60	40	60	40	40
TMA 200	248	248	50	70	50	70	60	50

	h	m	∅ n	R	r2	r3	s2	s3	∅ u	∅ v
TMA 15	75	25	38	21	20	20	21	15.5	20	16
TMA 25	100	30	48	27	25	25	16	13	25	20
TMA 50	120	40	68	37	35	35	22	19	35	30
TMA 100	140	50	78	46	40	40	28	23	40	40
TMA 150	180	60	90	56	50	50	35	30	50	50
TMA 200	210	75	108	68	60	60	44	38	60	60

Linear actuators TMA Series

5.5 OVERALL DIMENSIONS - input gearbox

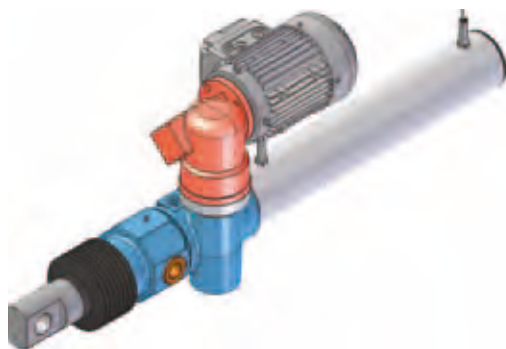

Configurations: 1, 2, 3 and 4



Configurations: 5, 6, 7 and 8

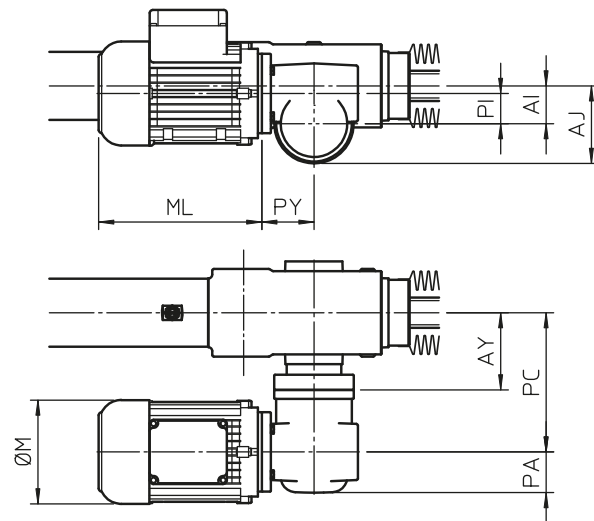
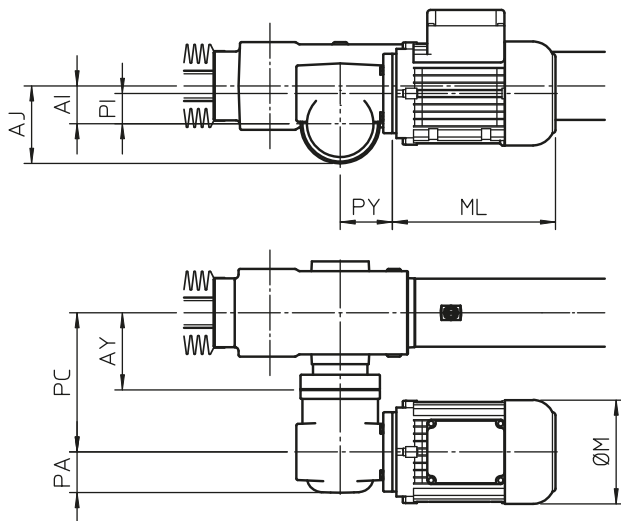

5

ACTUATOR	INPUT GEARBOX	AI	AJ	AY	PA	PC	PI	PY	Ø M	ML
TMA 15	I 25	30	75	62	44	123	25	58	110	168
TMA 25	I 25	40	85	69	44	130	25	58	110	168
	I 30	40	85	69	49	142	30	62	123	198
TMA 50	I 30	50	103	102	49	175	30	62	123	198
	I 40	50	103	102	54	184	40	69	137	216
TMA 100	I 40	63	123	100	54	182	40	69	137	216

For dimensions of the actuator with input gearbox not stated in this table please contact SERVOMECH.

Linear actuators TMA Series

5.6 OPTIONS

ACTUATOR INPUT – size 15

Single input shaft

Code: **Vers.1**

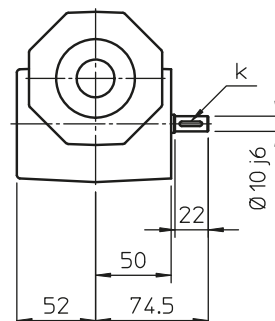
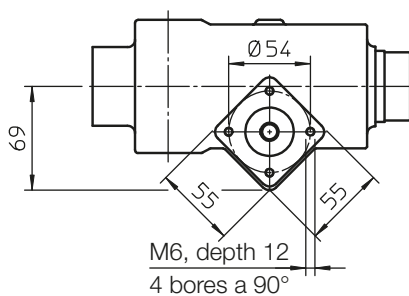

Double input shaft

Code: **Vers.2**

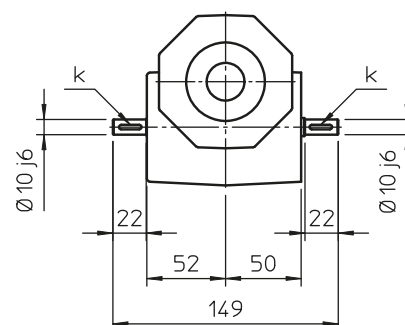
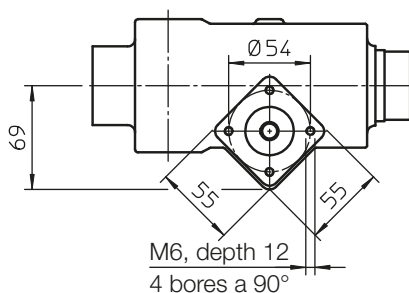

Attachment for IEC _ B14 electric motor (flange and hollow shaft)

Code: **Vers.3**

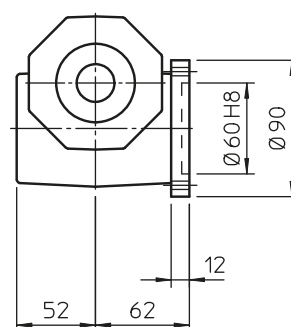
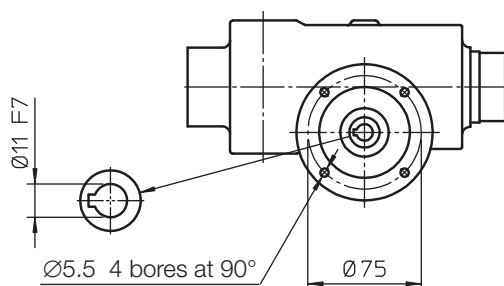

Attachment for IEC _ B14 electric motor (flange and hollow shaft) and second shaft

Code: **Vers.4**

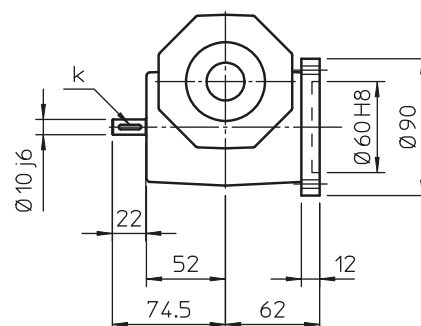
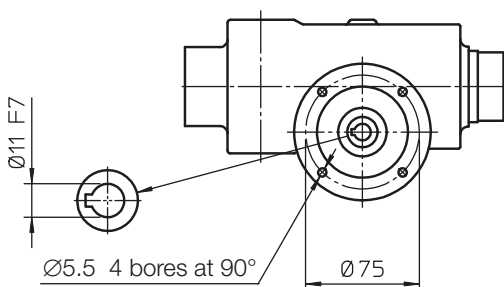

Linear actuators TMA Series

5.6 OPTIONS

ACTUATOR INPUT – size 25 - 50 - 100 - 150 - 200

Single input shaft

Code: **Vers.1**

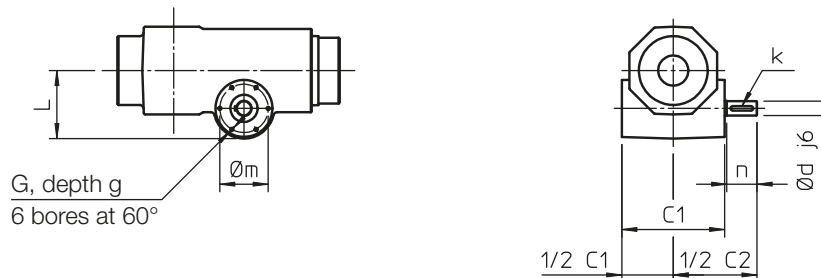

Double input shaft

Code: **Vers.2**

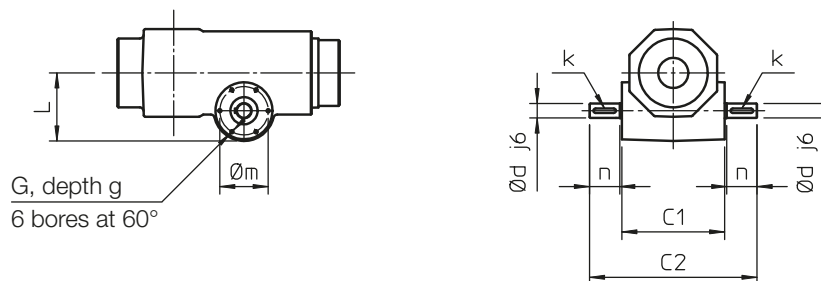

Attachment for IEC _ B5 or B14 electric motor (flange and hollow shaft)

Code: **Vers.3**

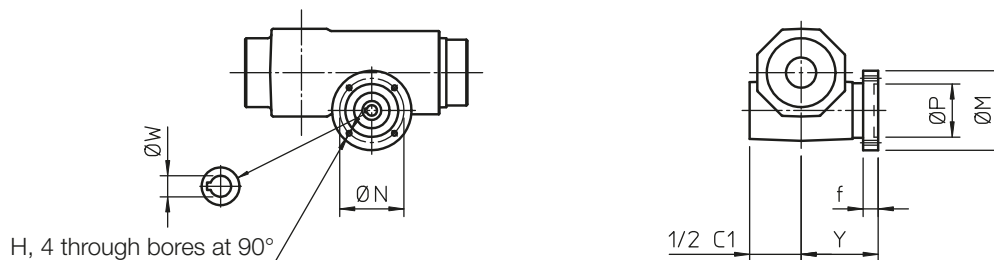

Attachment for IEC _ B5 or B14 electric motor (flange and hollow shaft) and second shaft

Code: **Vers.4**

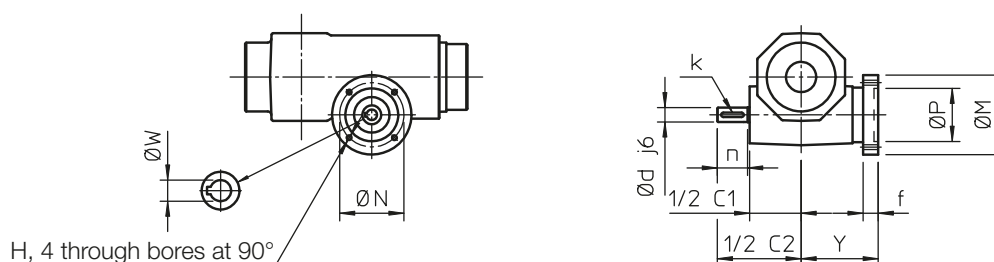

5

Linear actuators TMA Series

5.6 OPTIONS

ACTUATOR INPUT – size 25 - 50 - 100 - 150 - 200

Attachment for IEC _ B14 electric motor (adapter and coupling)

Code: **Vers.5**

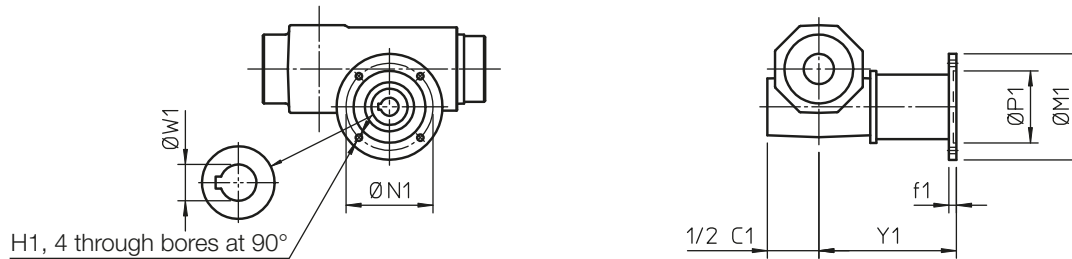

Attachment for IEC _ B14 electric motor (adapter and coupling) and second shaft

Code: **Vers.6**

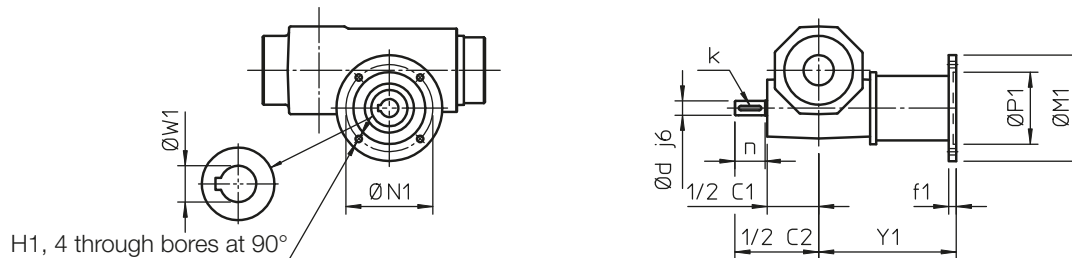

	C1	C2	G	L	g	Ø d	k	Ø m	n
TMA 25	114	179	M5	70	12	14	5x5x20	46	30
TMA 50	136	222	M5	90	10	19	6x6x30	64	40
TMA 100	165	269	M6	104	14	24	8x7x40	63	50
TMA 150	165	269	M6	104	14	24	8x7x40	63	50
TMA 200	205	330	M6	143	14	28	8x7x40	74	60

Attachment for IEC electric motor: flange and hollow shaft

	Motore IEC	H	Ø M	Ø N	Ø P	Ø W	Y	f
TMA 25	63 B14	Ø 5.5	90	75	60	11	69	8
TMA 50	71 B14	Ø 7	105	85	70	14	102	20
TMA 100	80 B5	M10	200	165	130	19	100	12
TMA 150	80 B5	M10	200	165	130	19	100	12
TMA 200	80 B5/90 B5	M10	200	165	130	19 24	119	12

Attachment for IEC electric motor: adapter and coupling

	IEC motor		H1	Ø M1		Ø N1		Ø P1		Ø W1		Y1		f1
TMA 25	71 B14		Ø 6.5	105		85		70		24		138		8
TMA 50	80 B14	90 B14	Ø 6.5 Ø 8.5	120	140	100	115	80	95	19	24	176	182	10 10
TMA 100	90 B14	100-112 B14	Ø 8.5 Ø 8.5	140	160	115	130	95	110	24	28	200	220	10 15
TMA 150	90 B14	100-112 B14	Ø 8.5 Ø 8.5	140	160	115	130	95	110	24	28	200	220	10 15
TMA 200	100 -112 B14		Ø 8.5	160		130		110		28		240		15

Linear actuators TMA Series

5.6 ACCESSORIES

INDUCTIVE PROXIMITY STROKE END SWITCHES Code FCP

The INDUCTIVE PROXIMITY STROKE END SWITCHES FCP allow the actuator to stop before reaching the internal mechanical stop avoiding damage. They can be also used to fix intermediate positions along the actuator stroke length.

The INDUCTIVE PROXIMITY STROKE END SWITCHES are fixed directly on the actuator outer tube in the required position and are activated by the ferrous-metal ring, which is positioned at the acme screw end.

In case the screw jack is not stopped after the sensor activation, when the ferrous-metal ring moves away, the sensor restores the original state (becomes deactivated). In case the limit switches are used to stop the actuator, an electric connection with electric check is recommended, in order to prevent that the actuator keeps moving in the same direction.

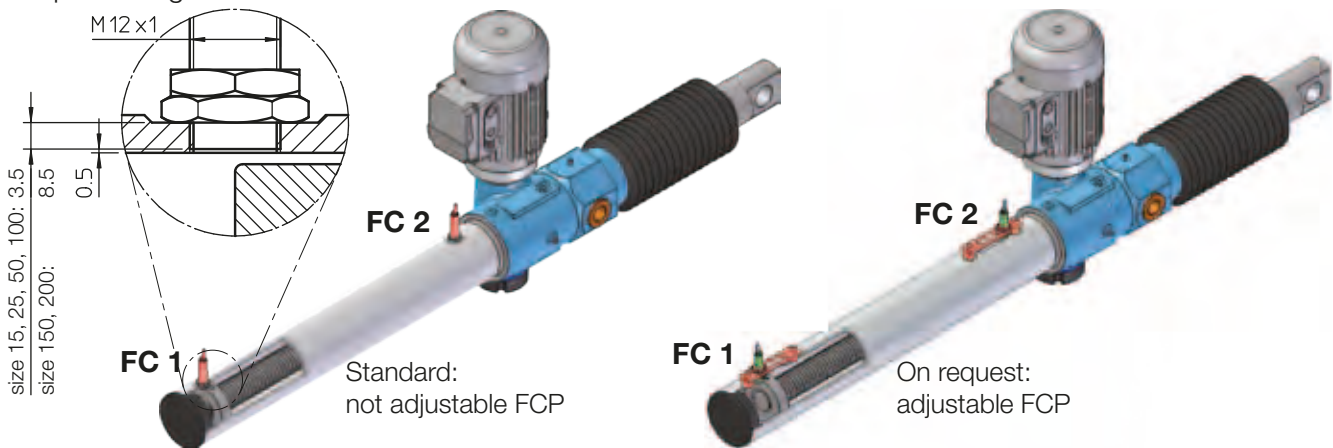

- RETRACTED ACTUATOR (Lc): sensor FC 1
- EXTENDED ACTUATOR (La): sensor FC 2

In the standard arrangement, the position of the switches along the tube is not adjustable and it is not angularly fixed. Design with angular position according to customer's requirements is available on request.

Design with axial adjustment of the sensors position is also available on request.

ELECTRIC FEATURES

Type:	inductive, PNP
Contact:	normally CLOSED (NC)
Voltage:	(10 ... 30) V DC
Max. output current:	200 mA
Voltage drop (activated switch)	< 3 V (at 200 mA)
Wires:	3 x 0.2 mm ²
Cable length:	2 m

CONTROL CIRCUIT

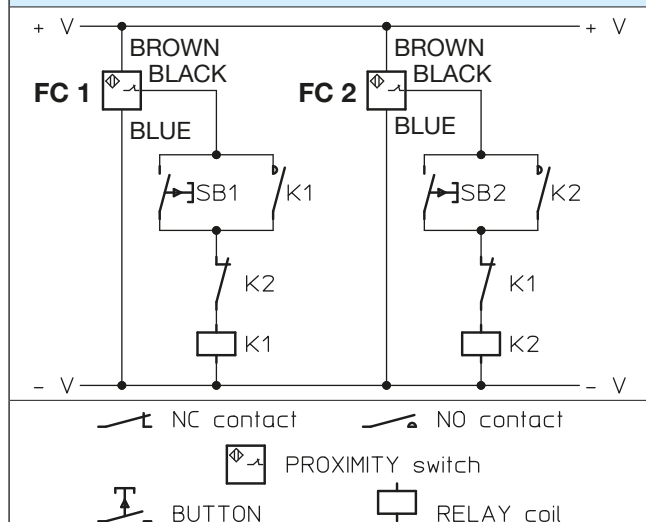

WIRING DIAGRAM

AC 3-phase motor

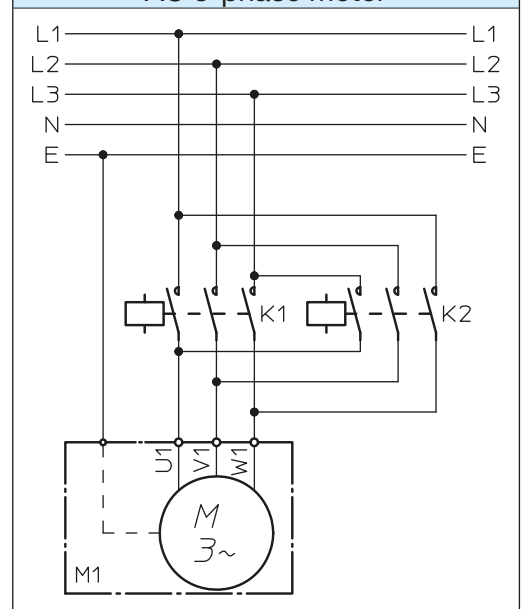

Linear actuators TMA Series

5.6 ACCESSORIES

ELECTRIC STROKE END SWITCHES Code FC

The ELECTRIC STROKE END SWITCHES FC allow to limit the actuator stroke avoiding to reach the extreme positions (mechanical stops) and preventing damage. The device consists of two switch assemblies, each of them consisting of one miniature electric switch (FC 1, FC 2) fixed to the relative support, a switch operating cam, rotating around the relative support pin when operated by the ferrous-metal ring fixed to the acme screw end and a spring that allows the return of the cam to its neutral position, thus deactivating the switch; the entire assembly is covered by an aluminium cover and sealed by a rubber seal. Each assembly determines one of the two extreme positions of the push rod (Lc or La), but it can not be used to fix any intermediate position. The position of the assembly along the outer tube is not adjustable.

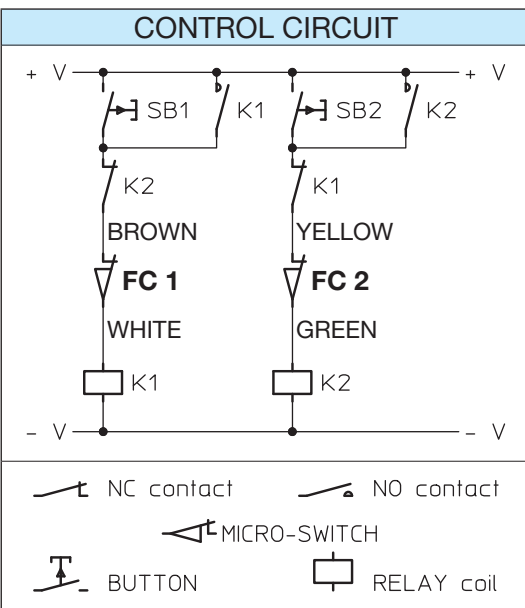
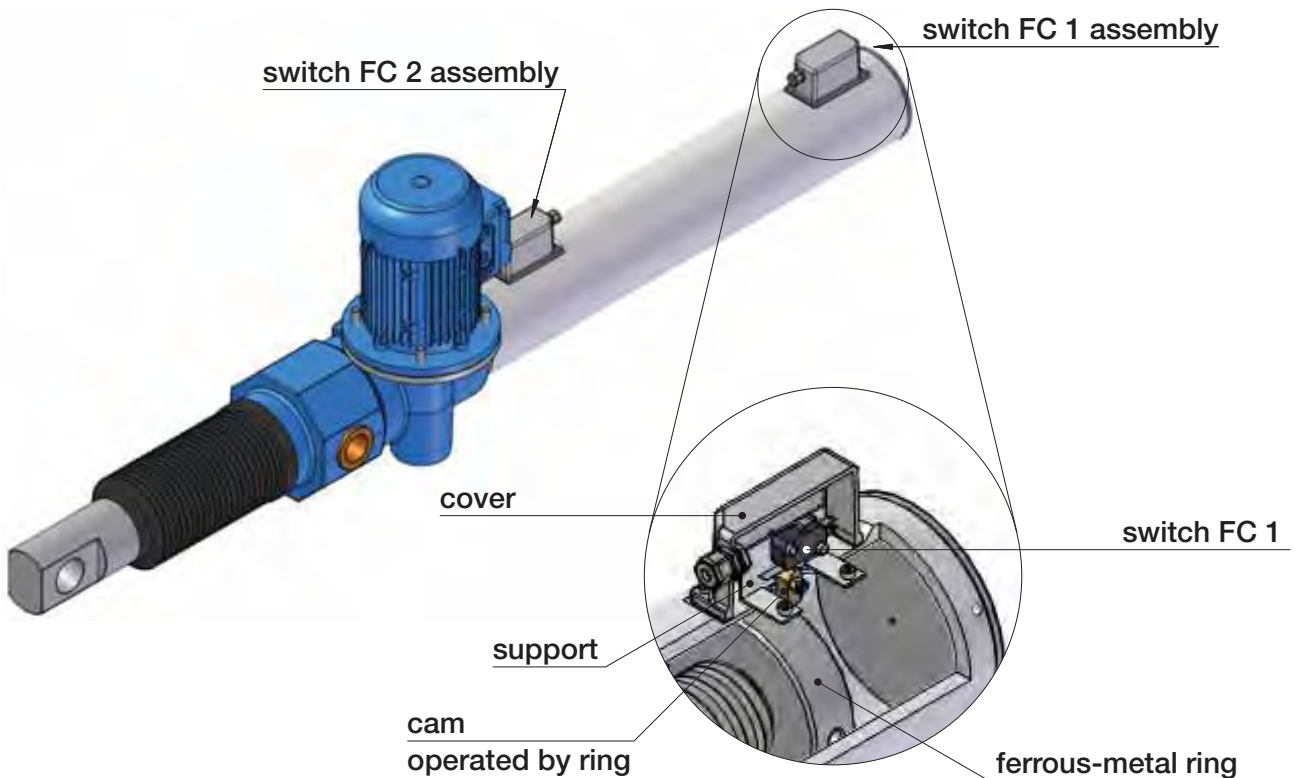

The ELECTRIC STROKE END SWITCHES FC must be connected to the electric control circuit to guarantee the motor switch off and to prevent damages to the actuator and the application equipment. The relevant WIRING DIAGRAM is on page 176.

The ELECTRIC STROKE END SWITCHES FC equipped with 2 multi-core cables 2 × 0.75 mm², standard length 1.5 m, longer cable on request. The wire colours are indicated in the CONTROL CIRCUIT on the left.

RATED CONTACT VALUES			
Voltage	250 V AC	125 V AC	125 V DC
Current (resistive load)	16 A	16 A	0.6 A
Current (inductive load)	10 A	10 A	0.6 A

The ELECTRIC STROKE END SWITCHES FC are available for actuators TMA 100, TMA 150 and TMA 200.

Linear actuators TMA Series

5.6 ACCESSORIES

PROTECTIVE BELLOWS Code B

When the actuators are used in severe environment conditions with contaminant agents that can damage the seal scraper between the outer tube and the push rod, BELLOWS protection can be useful.

Bellows made of special materials for severe environments are available upon request.



ROTARY ENCODER Code ENC.4

Hall-effect encoder, incremental, bi-directional

Resolution: 4 pulses per revolution

Output: PUSH-PULL

2 channels (phase difference 90°)

Input voltage: (8 ... 32) Vdc

Max. commutable current: 100 mA

Max output voltage drop:

with load connected to 0 and $I_{out} = 100 \text{ mA}$: 4.6 V

with load connected to + V and $I_{out} = 100 \text{ mA}$: 2 V

Protection:

against short circuit

against input polarity inversion

against any incorrect output connection

Cable length: 1.3 m

Protection: IP 55

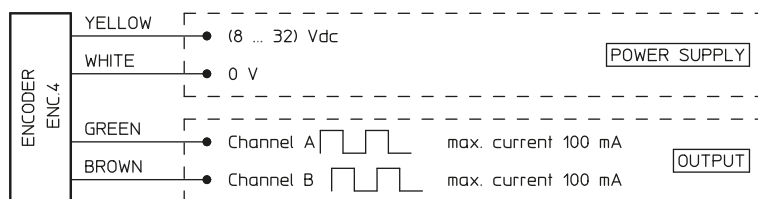

5.7 SPECIAL DESIGNS

According to specific application requirements, special designs can be carried out on standard actuators.

Some possible options are for example:

- acme screw in stainless steel AISI 303
- lubricants for high or low ambient temperature
- seals in VITON or silicone

Thanks to the long experience and know-how, SERVOMECH is able to support customers in selecting the right actuator version and accessories suitable for specific environment and installation conditions.



5

Application example of linear actuator TMA Series: solar tracker

Linear actuators TMA Series

5.8 ORDERING CODE

TMA	50	Config.1	RL1	C800	TF	B	FCP
1	2	3	4	5	6	7	8
Vers.3							
9							
input gearbox I 30 RL							
10							
AC 3-phase motor 0.37 kW 4-pole 230/400 V 50 Hz IP 55 Ins. F							
11							

1	Actuator series TMA	
2	Actuator size 15, 25, 50, 100, 150, 200	pages 158 ... 159
3	Actuator configuration Config.1 ... Config.8	pages 162 ... 163
4	Ratio RV1, RN1, RL1, RXL1	pages 158 ... 159
5	Stroke code (C...)	
6	Front attachment TF - hinged head TS - ball joint	pages 164 ... 172
7	Bellows	page 178
8	Stroke end switches FCP - inductive proximity switches FC - electric switches	page 176 page 177
9	Actuator input Vers.1 - single input shaft Vers.2 - double input shaft Vers.3 - attachment for IEC motor (flange and hollow shaft) Vers.4 - attachment for IEC motor (flange and hollow shaft) + second shaft Vers.5 - attachment for IEC motor (adapter and coupling) Vers.6 - attachment for IEC motor (adapter and coupling) + second shaft	pages 173 ... 175
10	Input gearbox	page 161
11	Motor data	pages 200 ... 201
12	Other specifications example: acme screw in stainless steel AISI 303 example: lubricant for low temperature	
13	Filled in SELECTION DATA sheet	page 181
14	Application layout	

APPLICATION: _____

REQUIRED STROKE: _____ mm

REQUIRED LINEAR SPEED: _____ mm/s _____ mm/min _____ m/min TIME TO PERFORM 1 STROKE: _____ s

STATIC LOAD: PULL: _____ N PUSH: _____ N at STROKE _____ mm

DYNAMIC LOAD: PULL: _____ N PUSH: _____ N at STROKE _____ mm

ACTUATOR SUBJECTED TO VIBRATIONS NOT SUBJECTED TO VIBRATIONS

OPERATING: _____ cycle / hour _____ working hours / day Notes: _____

ENVIRONMENT: TEMPERATURE _____ °C DUST HUMIDITY _____ % AGGRESSIVE AGENT _____

Size: 15 25 50 100 150 200

Ratio: RV1 RN1 RL1 RXL1

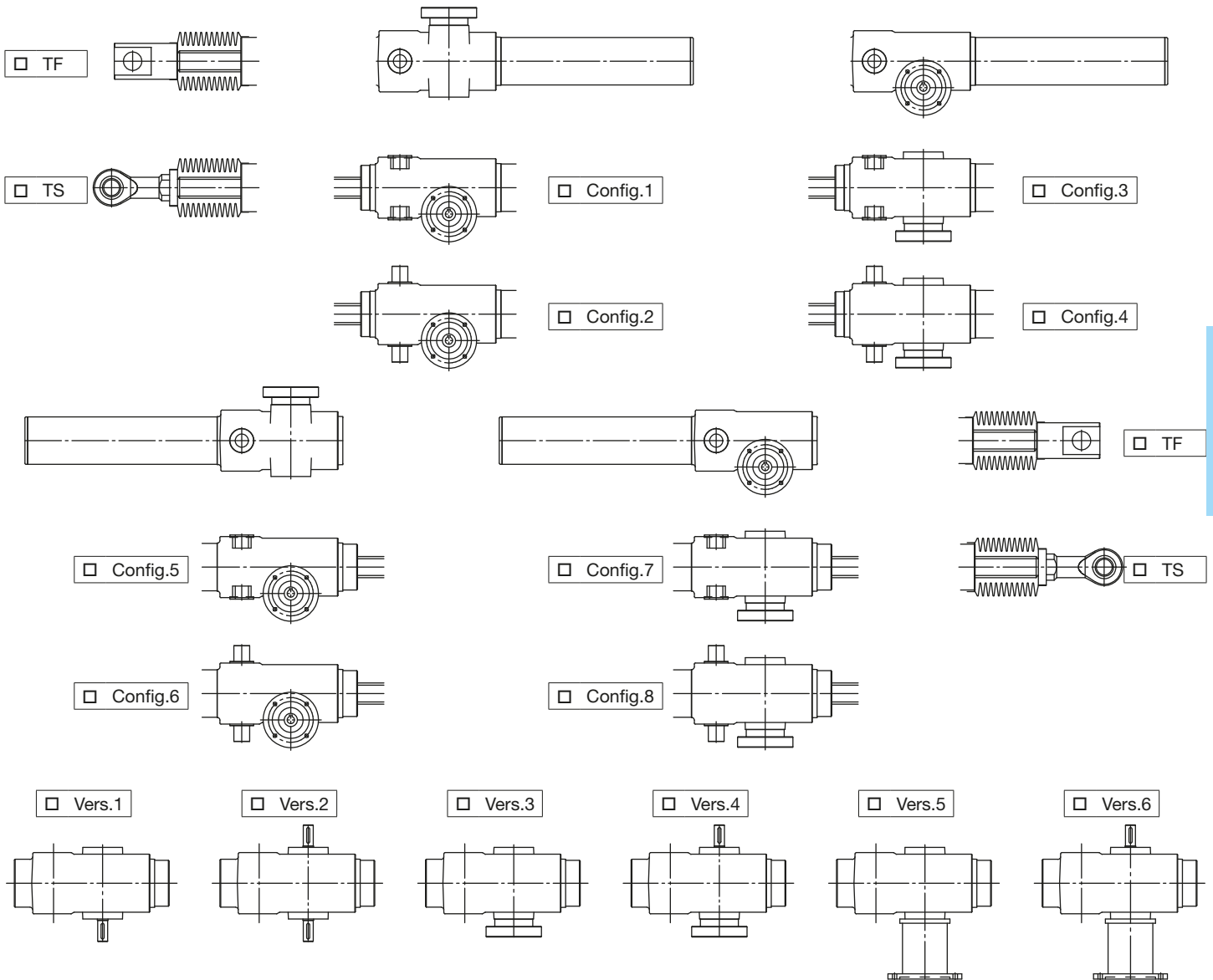

INPUT GEARBOX _____ ELECTRIC MOTOR AC 3-phase _____

STROKE END SWITCHES PROXIMITY FCP ELECTRIC FC ROTARY ENCODER

BELLOWS

OTHER: _____

PRODUCT: _____

- | | |
|--------------------------|---------------------------|
| <input type="checkbox"/> | WITHOUT input gearbox |
| <input type="checkbox"/> | WITH input gearbox _____ |
| <input type="checkbox"/> | WITHOUT electric motor |
| <input type="checkbox"/> | WITH electric motor _____ |

Product serial number: _____ ; q.ty: _____

HINGED HEAD

TF

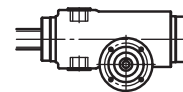
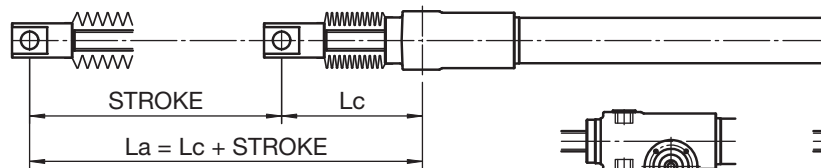

Config.1

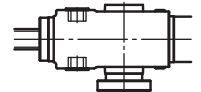

Config.3

BALL JOINT

TS

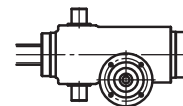
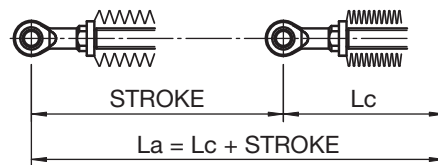

Config.2

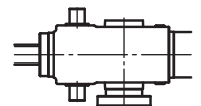

Config.4

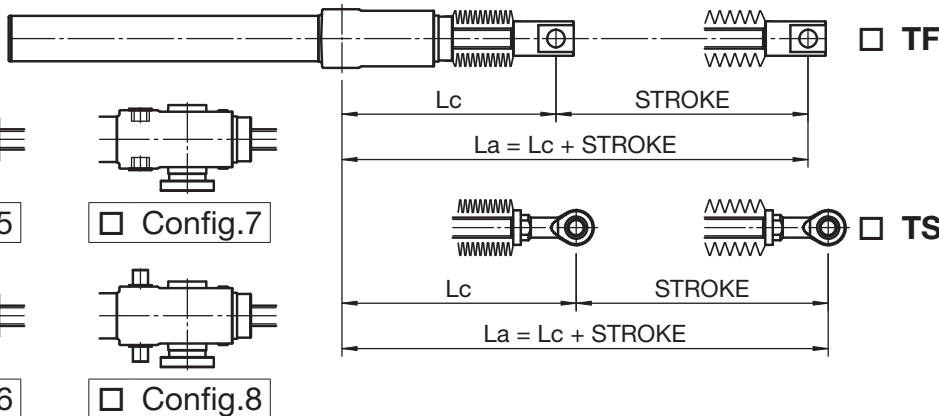

TF

HINGED HEAD

TS

BALL JOINT

LINEAR ACTUATOR LENGTH

WORKING RANGE

RETRACTED ACTUATOR length: $L_c =$ _____ mm
 EXTENDED ACTUATOR length: $L_a =$ _____ mm
 STROKE ($L_a - L_c$): $C =$ _____ mm

INTERNAL MECHANICAL STOP LIMIT

MIN. actuator length: _____ mm
 MAX. actuator length: _____ mm

<p>PASSED</p>	
Date: _____	Signature: _____

PROXIMITY STROKE END SWITCHES **FCP** □

The PROXIMITY STROKE END SWITCHES **FCP** has proximity sensors FC 1 and FC2.

- type: inductive, PNP
- contact: **normally CLOSED**
- supply voltage: (10 ... 30) V DC
- max. output current: 200 mA
- max. voltage drop (activated sensor): < 3 V (ref. 200 mA)

FC1 - sensor for RETRACTED ACTUATOR position
FC2 - sensor for EXTENDED ACTUATOR position

SINGLE SENSOR WIRING:

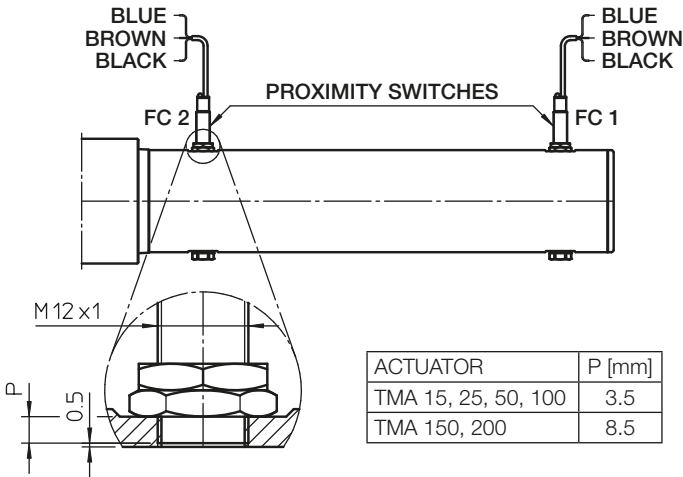

ELECTRIC STROKE END SWITCHES **FC** □

The ELECTRIC STROKE END SWITCHES **FC** has miniature switches FC 1 and FC 2.

- contact: **normally CLOSED**
- voltage: 250 V DC / 125 V DC / 125 V DC
- current: 16 A / 16 A / 0.6 A (resistive load)
10 A / 10 A / 0.6 A (inductive load)

FC1 - switch for RETRACTED ACTUATOR position
The wires that connect the switch FC 1 are WHITE and BROWN.
FC2 - switch for EXTENDED ACTUATOR position
The wires that connect the switch FC 2 are GREEN and YELLOW.

SINGLE SWITCH WIRING:

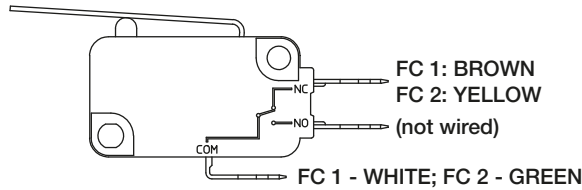

WARNING!

1. The values **Lc** (RETRACTED ACTUATOR length), **La** (EXTENDED ACTUATOR length) and **C** (STROKE) are the extreme limit values.
2. **BEFORE** using the linear actuator:
 - verify the input shaft rotating direction and the acme screw running direction;
 - make sure that the motor and the limit switches are correctly connected and that the correct voltage is used.
3. **Alignment check:** the load must be in line with the actuator. No off-set or radial loads are allowed.

NOTE: _____

WORMGEAR LUBRICANT: _____

SCREW – NUT LUBRICANT: _____

Linear actuators ILA Series

Linear Actuator ILA Series without input drive, with flange and input shaft



Linear Actuator ILA Series with input drive

- with 2 bevel gearmotors

- with single bevel gearmotor

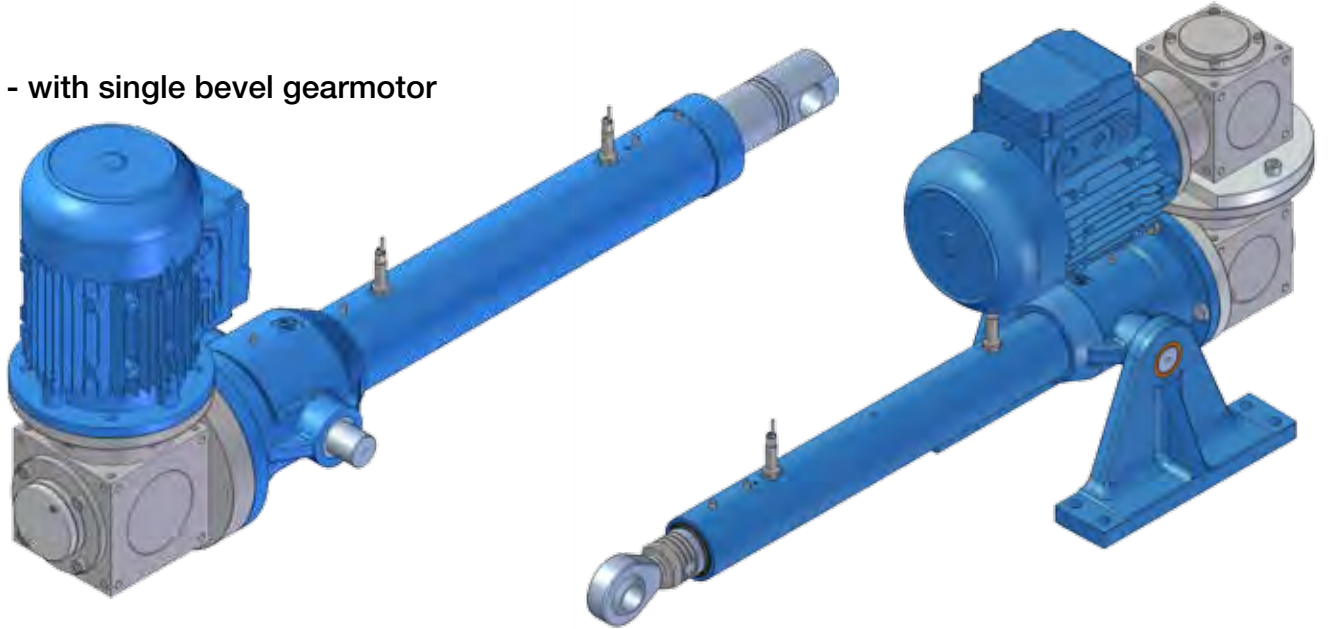

- with helical coaxial or planetary gearmotor

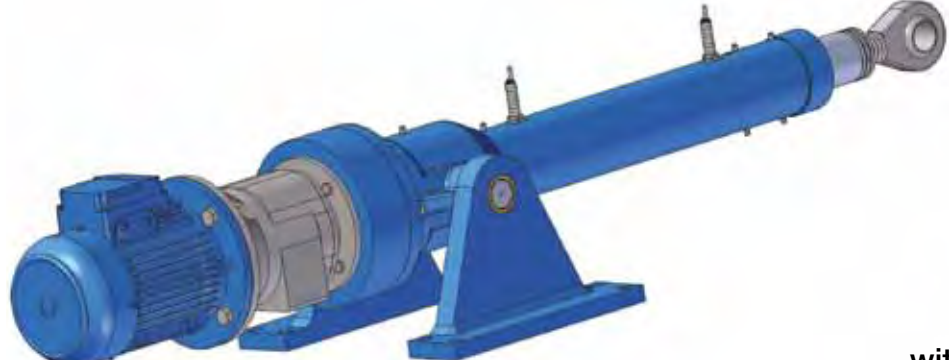

- with bevel-helical gearmotor



6

Linear actuators ILA Series

6.1 MANUFACTURING FEATURES

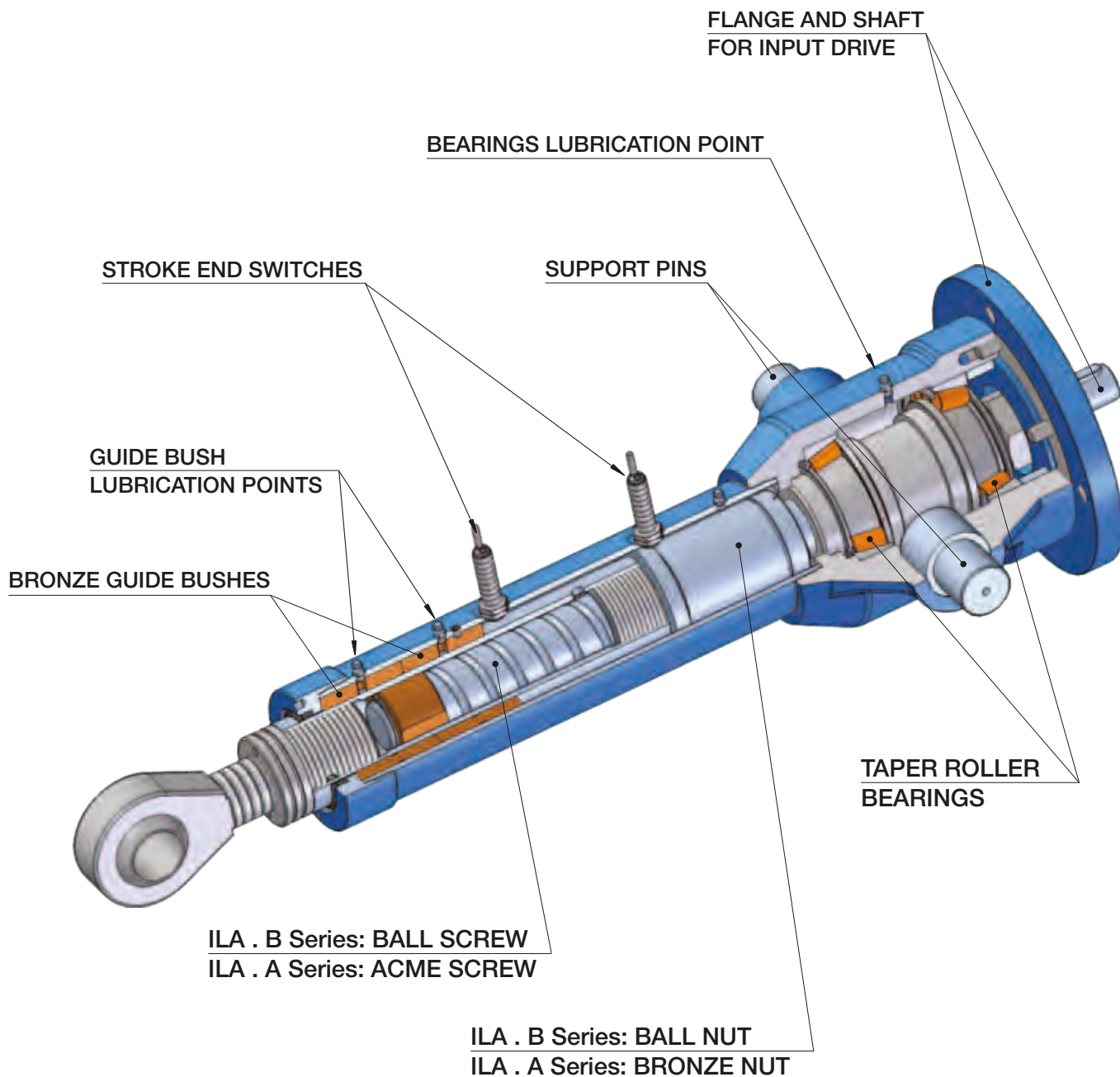

Linear actuators ILA Series

6.2 TECHNICAL DATA - acme screw linear actuators ILA . A Series

SIZE		ILA 15 A	ILA 25 A	ILA 50 A
Load capacity [kN], (push - pull)		15	25	50
Push rod diameter	[mm]	40	50	60
Outer tube diameter	[mm]	60	70	90
Front attachment diameter	[mm]	20	30	35
Rear attachment diameter - pins	[mm]	20	30	35
Max. input solid shaft diameter	[mm]	12	16	24
1-start acme screw (code: 1)		Tr 22×5	Tr 30×6	Tr 40×7
Linear travel for 1 input shaft revolution	[mm]	5	6	7
Starting efficiency		0.38	0.35	0.31
Running efficiency at 100 rpm		0.45	0.42	0.42
Reaction torque on front attachment at max. load	[Nm]	32	69	180
2-start acme screw (code: 2)		Tr 22×10 (P5)	Tr 30×12 (P6)	Tr 40×14 (P7)
Linear travel for 1 input shaft revolution	[mm]	10	12	14
Starting efficiency		0.54	0.51	0.47
Running efficiency at 100 rpm		0.61	0.59	0.58
Reaction torque on front attachment at max. load	Nm]	45	94	237
Mass (actuator 100 mm stroke length, with lubricant)	[kg]	10	17	37
Extra-mass for each additional 100 mm stroke length	[kg]	0.9	2	3

Linear actuators ILA Series

6.2 TECHNICAL DATA - acme screw linear actuators ILA . A Series

ILA 100 A	ILA 150 A	ILA 200 A	SIZE
100	150	200	Load capacity [kN], (push - pull)
80	90	110	Push rod diameter [mm]
130	150	180	Outer tube diameter [mm]
40	45	50	Front attachment diameter [mm]
40	45	50	Rear attachment diameter - pins [mm]
32	38	42	Max. input solid shaft diameter [mm]
Tr 55×9	Tr 60×12	Tr 80×12	1-start acme screw (code: 1)
9	12	12	Linear travel for 1 input shaft revolution [mm]
0.30	0.35	0.28	Starting efficiency
0.42	0.47	0.41	Running efficiency at 100 rpm
478	819	1 706	Reaction torque on front attachment at max. load [Nm]
Tr 55×18 (P9)	Tr 60×24 (P12)	Tr 80×24 (P12)	2-start acme screw (code: 2)
18	24	24	Linear travel for 1 input shaft revolution [mm]
0.46	0.51	0.43	Starting efficiency
0.58	0.63	0.58	Running efficiency at 100 rpm
562	1 124	2 222	Reaction torque on front attachment at max. load Nm
74	103	144	Mass (actuator 100 mm stroke length, with lubricant) [kg]
6	7.5	12	Extra-mass for each additional 100 mm stroke length [kg]

Linear actuators ILA Series

6.2 TECHNICAL DATA - ball screw linear actuators ILA . B Series

SIZE		ILA 15 B	ILA 25 B	ILA 50 B
Load capacity [kN], (push - pull)		15	25	50
Push rod diameter	[mm]	40	50	60
Outer tube diameter	[mm]	60	70	90
Front attachment diameter	[mm]	20	30	35
Rear attachment diameter - pins	[mm]	20	30	35
Max. input solid shaft diameter	[mm]	16	16	24
Ball screw (code: 1)	Diameter × Lead	25×6	32×10	40×10
	Ball [mm]	3.969 (5/32 ")	6.35 (1/4 ")	6.35 (1/4 ")
	Number of circuits	3	4	5
	Dynamic load C _a [N]	17 400	41 800	60 000
	Static load C _{0a} [N]	30 500	73 000	124 000
Linear travel for 1 input shaft revolution		6	10	10
Required torque on input shaft at max. load [Nm]		16	45	89
Ball screw (code: 2)	Diameter × Lead	25×10	32×20	40×20
	Ball [mm]	3.969 (5/32 ")	6.35 (1/4 ")	6.35 (1/4 ")
	Number of circuits	3	3	3
	Dynamic load C _a [N]	14 000	32 200	38 500
	Static load C _{0a} [N]	25 700	53 000	74 000
Linear travel for 1 input shaft revolution		10	20	20
Required torque on input shaft at max. load [Nm]		27	90	177
Mass (actuator 100 mm stroke length, without motor, with lubricant) [kg]		10	18	36
Extra-mass for each additional 100 mm stroke length [kg]		0.9	2	3

Linear actuators ILA Series

6.2 TECHNICAL DATA - ball screw linear actuators ILA . B Series

ILA 100 B	ILA 150 B	ILA 200 B	SIZE
100	150	200	Load capacity [kN], (push - pull)
80	90	110	Push rod diameter [mm]
130	150	180	Outer tube diameter [mm]
40	45	50	Front attachment diameter [mm]
40	45	50	Rear attachment diameter - pins [mm]
32	38	42	Max. input solid shaft diameter [mm]
50×10	63×10	80 ×16	Diameter × Lead
7.144 (9/32 ")	7.144 (9/32 ")	9.525 (3/8 ")	[mm] Ball
5	6	5	Number of circuits
83 000	112 000	149 000	[N] Dynamic load C _a
188 000	313 000	393 000	[N] Static load C _{0a}
10	10	16	Linear travel for 1 input shaft revolution
177	266	442	Required torque on input shaft at max. load [Nm]
50×20	63×20	80 ×20	Diameter × Lead
7.144 (9/32 ")	9.525 (3/8 ")	12.7 (1/2 ")	[mm] Ball
4	4	4	Number of circuits
65 000	101 000	213 000	[N] Dynamic load C _a
140 000	220 000	516 000	[N] Static load C _{0a}
20	20	20	Linear travel for 1 input shaft revolution
354	531	885	Required torque on input shaft at max. load [Nm]
72	107	146	Mass (actuator 100 mm stroke length, without motor, with lubricant) [kg]
6	6	12	Extra-mass for each additional 100 mm stroke length [kg]



Linear actuators ILA Series

6.3 OVERALL DIMENSIONS - acme screw linear actuators ILA . A Series

Lc - RETRACTED actuator length
 La - EXTENDED actuator length

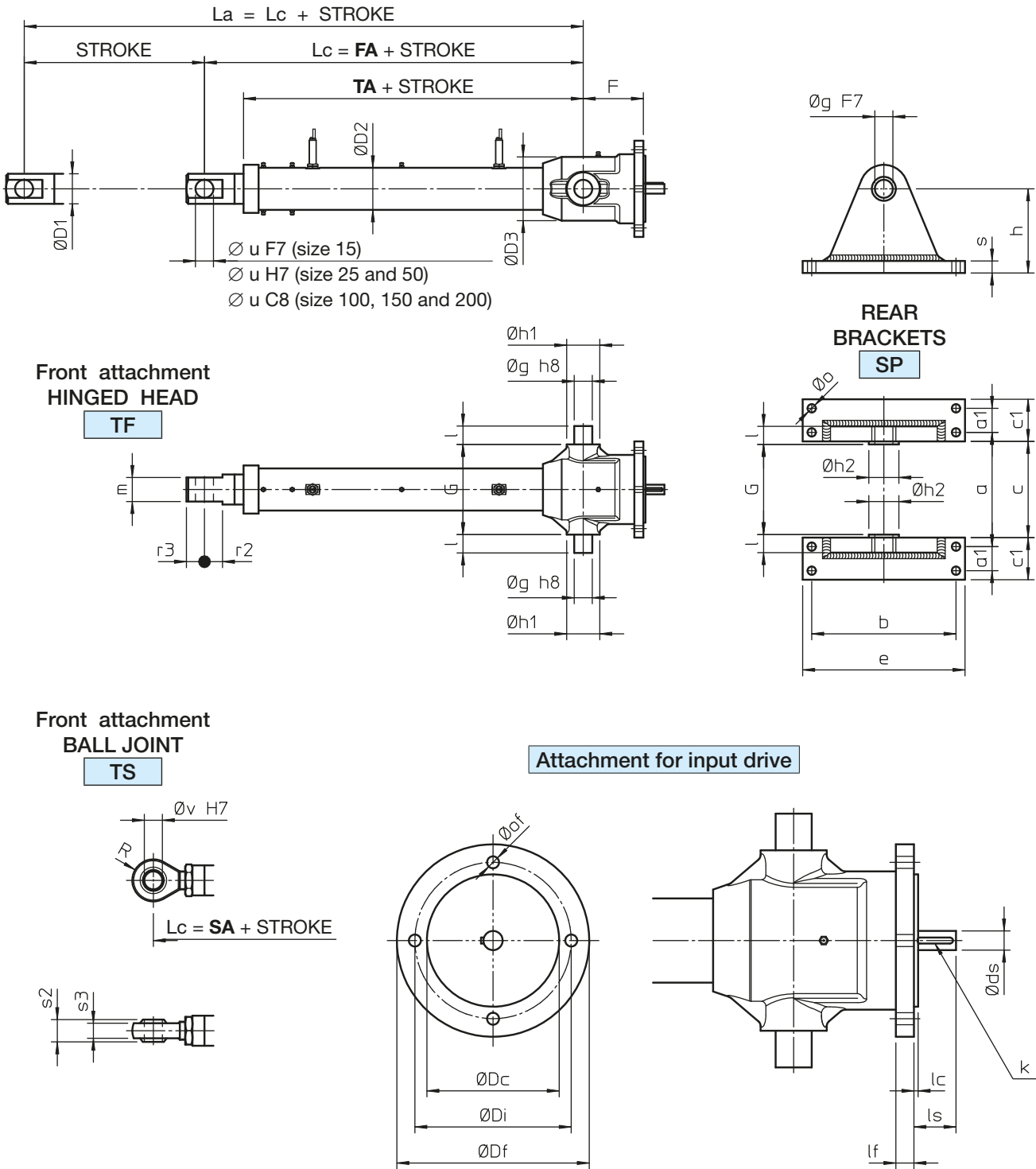

6

Linear actuators ILA Series

6.3 OVERALL DIMENSIONS - acme screw linear actuators ILA . A Series

	FA	SA	TA
ILA 15 A	207	248	166
ILA 25 A	275	310	210
ILA 50 A	351	407	282
ILA 100 A	436	466	346
ILA 150 A	468	506	376
ILA 200 A	484	519	377

Linear actuator and rear bracket dimensions:

	∅ D1	∅ D2	∅ D3	F	G	a	a1	b	c
ILA 15	40	60	86	78	140	172	26	190	148
ILA 25	50	70	106	98	150	190	40	240	160
ILA 50	60	90	140	114	200	240	50	270	210
ILA 100	80	130	170	147	240	292	60	310	252
ILA 150	90	150	190	149	280	342	75	370	292
ILA 200	115	180	220	150	332	404	100	410	344

	c1	e	∅ g	h	∅ h1	∅ h2	l	∅ o (n° of bores)	s
ILA 15	50	220	20	120	45	35	20	12 (4 bores)	15
ILA 25	70	270	30	140	55	50	30	14 (4 bores)	20
ILA 50	80	300	35	160	65	55	35	18 (4 bores)	20
ILA 100	100	360	40	185	75	60	40	22 (4 bores)	25
ILA 150	125	425	45	225	75	65	45	26 (4 bores)	30
ILA 200	160	470	50	250	100	70	50	32 (4 bores)	35

Input drive attachment dimensions:

	∅ Df	∅ Di	∅ Dc	∅ ds	k	lc	lf	ls	∅ of (n° of bores)
ILA 15 A	140	120	100	12	4x4x25	3.5	17	35	8 (4 bores)
ILA 25 A	160	140	120	16	5x5x30	3.5	13	40	10 (4 bores)
ILA 50 A	200	175	150	24	8x7x35	4	19	55	12.5 (4 bores)
ILA 100 A	250	215	180	32	10x8x40	4	25	60	14.5 (4 bores)
ILA 150 A	300	265	230	38	10x8x60	4	29	78	14.5 (4 bores)
ILA 200 A	350	300	250	42	12x8x60	4	33	110	18.5 (4 bores)

NOTE: On request, the dimensions of the input drive attachment can be different according to the dimensions of the drive unit to be mounted.

Front attachment dimensions:

	m	R	r2	r3	s2	s3	∅ u	∅ v
ILA 15 A	42	25	—	27	25	19	20	20
ILA 25 A	40	35	30	30	37	25	30	30
ILA 50 A	50	40	30	35	43	28	35	35
ILA 100 A	60	45	45	55	28	23	40	40
ILA 150 A	70	51	50	60	32	27	45	45
ILA 200 A	80	68	60	70	44	38	60	60



Linear actuators ILA Series

6.3 OVERALL DIMENSIONS - ball screw linear actuators ILA . B Series

Lc - RETRACTED actuator length
 La - EXTENDED actuator length

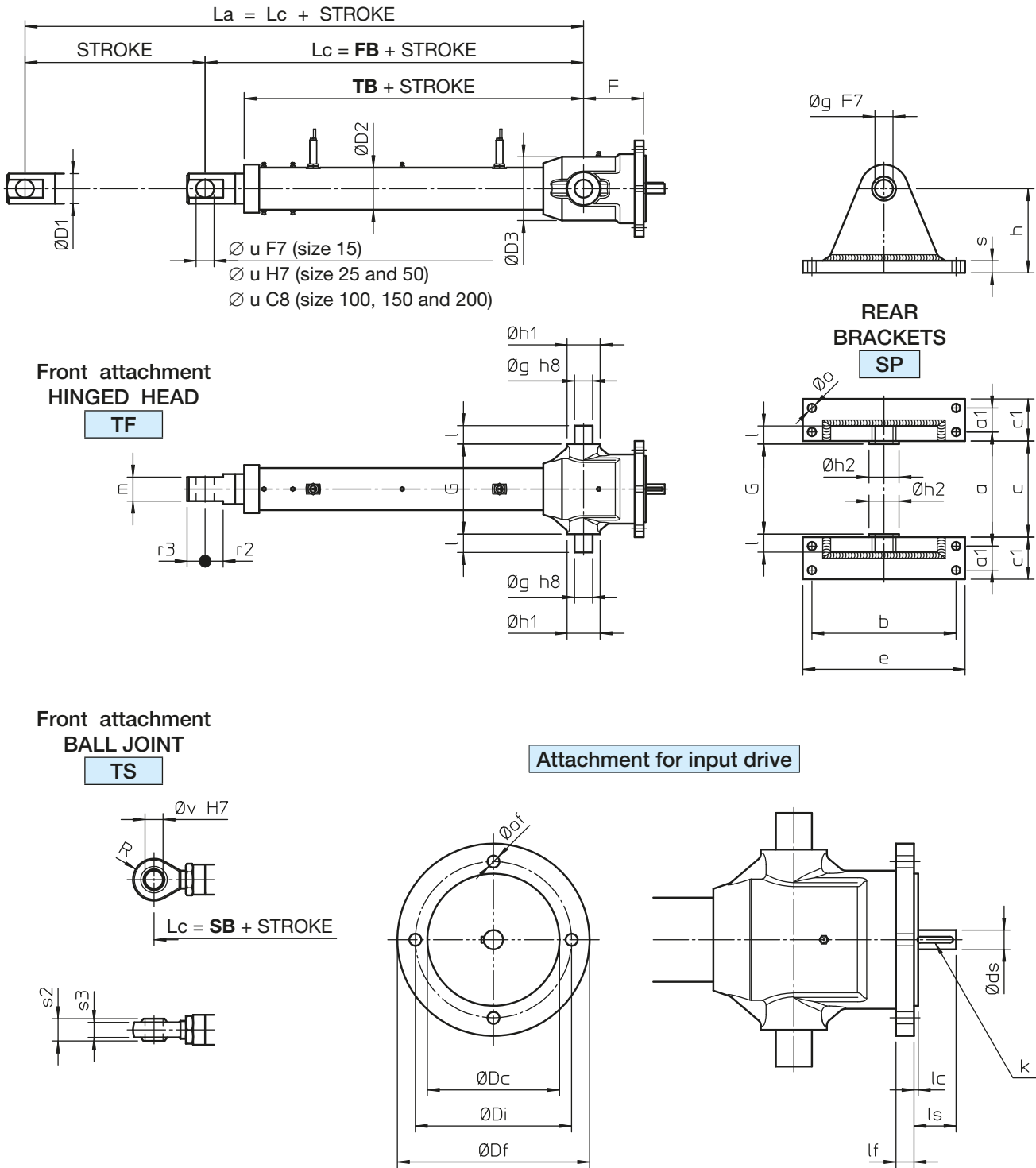

6

Linear actuators ILA Series

6.3 OVERALL DIMENSIONS - ball screw linear actuators ILA . B Series

	FB		SB		TB	
ILA 15 B	190 (BS 25×6)	208 (BS 25×10)	231 (BS 25×6)	249 (BS 25×10)	148 (BS 25×6)	166 (BS 25×10)
ILA 25 B	330		365		267	
ILA 50 B	371 (BS 40×10)	391 (BS 40×20)	427 (BS 40×10)	447 (BS 40×20)	309 (BS 40×10)	329 (BS 40×20)
ILA 100 B	436 (BS 50×10)	472 (BS 50×20)	466 (BS 50×10)	502 (BS 50×20)	344 (BS 50×10)	380 (BS 50×20)
ILA 150 B	484 (BS 63×10)	519 (BS 63×20)	522 (BS 63×10)	557 (BS 63×20)	390 (BS 63×10)	425 (BS 63×20)
ILA 200 B	532 (BS 80×16)	554 (BS 80×20)	567 (BS 80×16)	589 (BS 80×20)	432 (BS 80×16)	454 (BS 80×20)

Linear actuator and rear bracket dimensions:

	∅ D1	∅ D2	∅ D3	F	G	a	a1	b	c
ILA 15	40	60	86	78	140	172	26	190	148
ILA 25	50	70	106	98	150	190	40	240	160
ILA 50	60	90	140	114	200	240	50	270	210
ILA 100	80	130	170	147	240	292	60	310	252
ILA 150	90	150	190	149	280	342	75	370	292
ILA 200	115	180	220	150	332	404	100	410	344

	c1	e	∅ g	h	∅ h1	∅ h2	l	∅ o (n° of bores)	s
ILA 15	50	220	20	120	45	35	20	12 (4 bores)	15
ILA 25	70	270	30	140	55	50	30	14 (4 bores)	20
ILA 50	80	300	35	160	65	55	35	18 (4 bores)	20
ILA 100	100	360	40	185	75	60	40	22 (4 bores)	25
ILA 150	125	425	45	225	75	65	45	26 (4 bores)	30
ILA 200	160	470	50	250	100	70	50	32 (4 bores)	35

Input drive attachment dimensions:

	∅ Df	∅ Di	∅ Dc	∅ ds	k	lc	lf	ls	∅ of (n° of bores)
ILA 15 B	140	120	100	16	5×5×25	3.5	17	45	8 (4 bores)
ILA 25 B	160	140	120	16	5×5×30	3.5	13	40	10 (4 bores)
ILA 50 B	200	175	150	24	8×7×35	4	19	55	12.5 (4 bores)
ILA 100 B	250	215	180	32	10×8×40	4	25	60	14.5 (4 bores)
ILA 150 B	300	265	230	38	10×8×60	4	29	78	14.5 (4 bores)
ILA 200 B	350	300	250	42	12×8×60	4	33	110	18.5 (4 bores)

NOTE: On request, the dimensions of the input drive attachment can be different according to the dimensions of the drive unit to be mounted.

Front attachment dimensions:

	m	R	r2	r3	s2	s3	∅ u	∅ v
ILA 15 B	42	25	—	27	25	18	20	20
ILA 25 B	40	35	30	30	37	25	30	30
ILA 50 B	50	40	30	35	43	28	35	35
ILA 100 B	60	45	45	55	49	33	40	40
ILA 150 B	70	51	50	60	32	27	45	45
ILA 200 B	80	68	60	70	44	38	60	60

Linear actuators ILA Series

6.4 ACCESSORIES

INDUCTIVE PROXIMITY STROKE END SWITCHES Code FCP

The INDUCTIVE PROXIMITY STROKE END SWITCHES FCP allow the actuator to stop before reaching the internal mechanical stop avoiding damage. They can be also used to fix intermediate positions along the actuator stroke length.

The INDUCTIVE PROXIMITY STROKE END SWITCHES are fixed directly on the actuator outer tube in the required position. Their position is not adjustable. Standard proximity switches are normally closed.

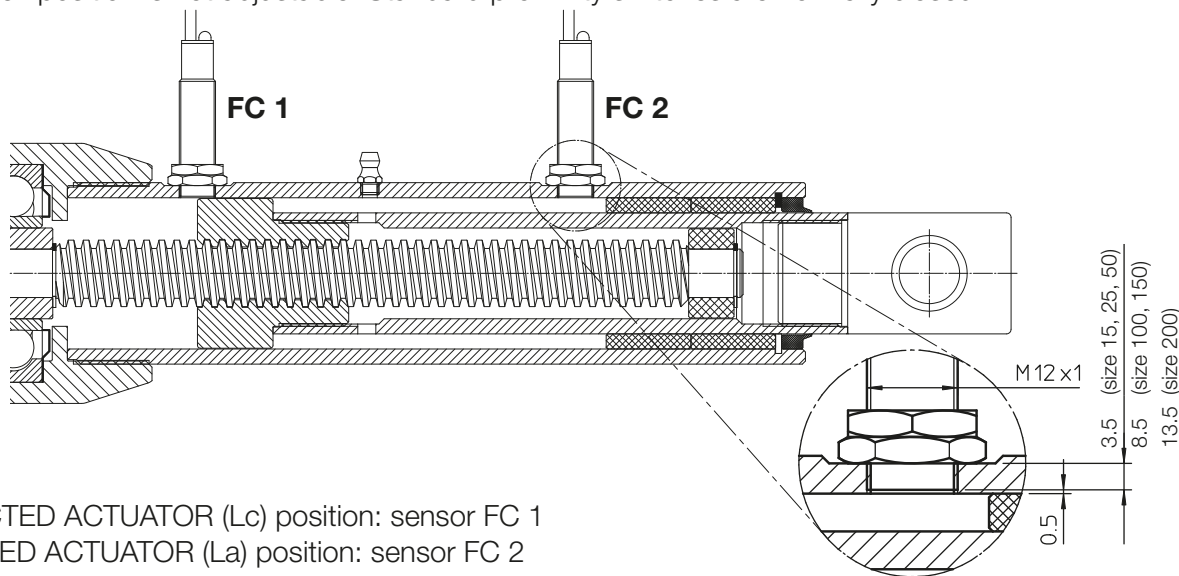

- RETRACTED ACTUATOR (Lc) position: sensor FC 1
- EXTENDED ACTUATOR (La) position: sensor FC 2

ELECTRIC FEATURES	
Type:	inductive, PNP
Contact:	normally CLOSED (NC)
Voltage:	(10 ... 30) V DC
Max. output current:	200 mA
Voltage drop (activated switch)	< 3 V (at 200 mA)
Wires:	3 × 0.2 mm ²
Cable length:	2 m

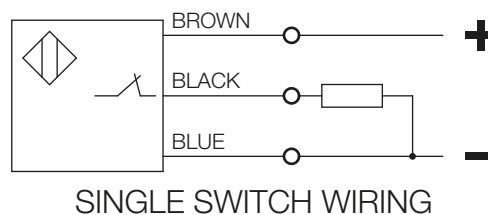

SAFETY NUT Code MS

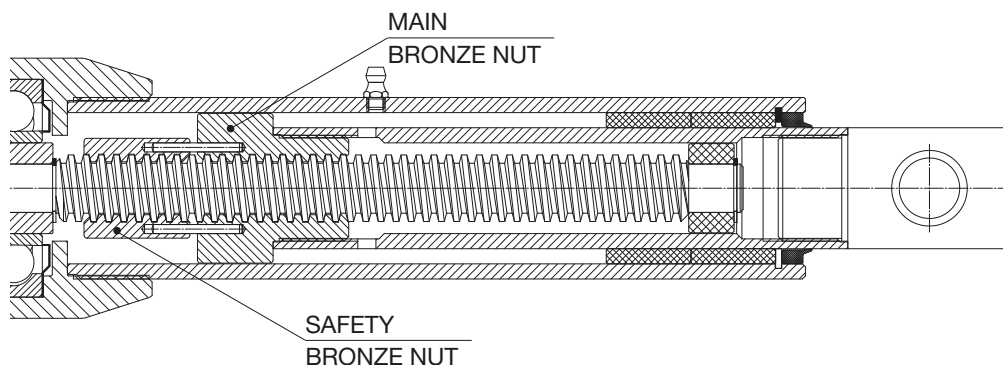

The SAFETY NUT is an auxiliary bronze nut connected by 2 pins to the main bronze nut. The distance between the two nuts in a new actuator is equal to a half of the thread pitch. If the main nut wears up to a half of the thread pitch or crashes, the SAFETY NUT supports the load avoiding its fall down.

The SAFETY NUT is a one-direction device. Its position with respect to the main nut depends on the load direction. The SAFETY NUT is available for actuators working with push load. For applications with pull load a special design is available (contact SERVOMECH).

The SAFETY NUT MS is available for all acme screw actuators (ILA . A Series).

Linear actuators ILA Series

6.4 ACCESSORIES

ANTI-TURN device Code AR

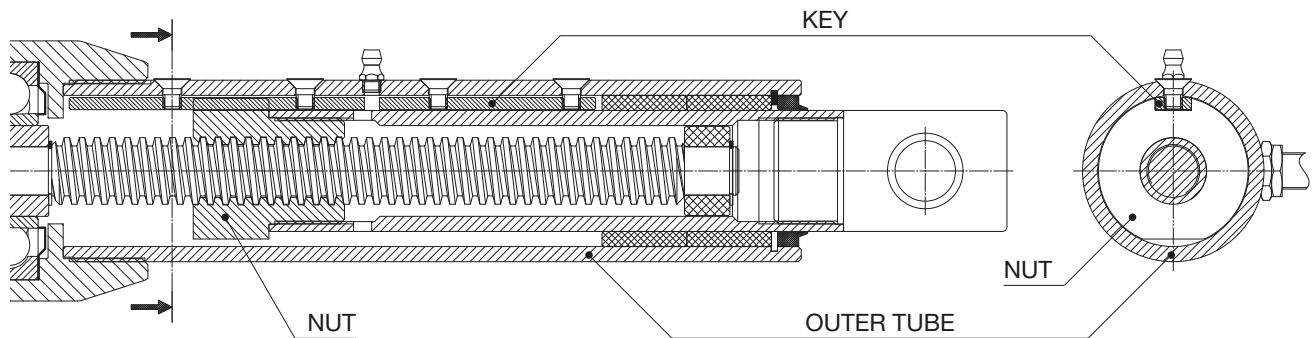

To achieve a linear motion it is necessary to prevent the rotary movement of the nut and of the push rod fixed to it. In many applications it is the external structure itself that, being connected to the push rod, prevents the rotation and allows the linear motion.

In some cases the load applied on the push rod cannot be guided and therefore the rotation cannot be avoided. In such cases it is necessary to use actuators with an internal anti-turn device. The ANTI-TURN device allows the linear motion without any external reaction on the push rod. It can be supplied upon request.

The anti-turn device shown in the above picture consists in a steel key fixed and aligned along the outer tube. The bronze nut, provided with a suitable keyway, slides on this key, making translate the push rod.

The ANTI-TURN device AR is available for all acme screw actuators (ILA . A Series).

PROTECTIVE BELLOWS Code B

When the actuators are used in severe environment conditions with contaminant agents that can damage the seal scraper between the outer outer tube and the push rod, BELLOWS protection can be useful.

Bellows made of special materials for severe environments are available upon request.

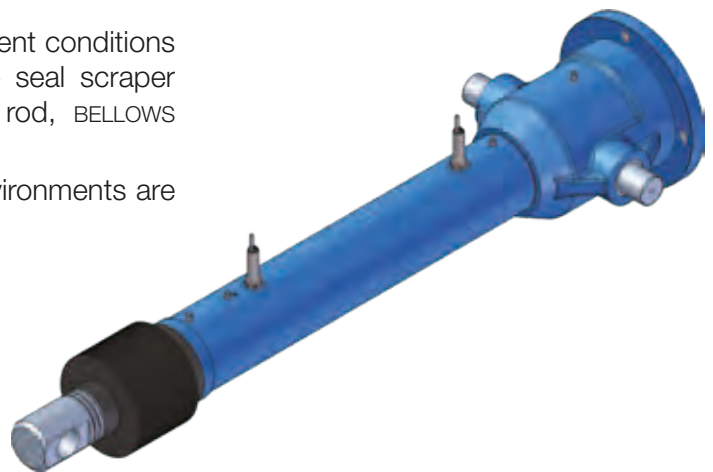

Linear actuators ILA Series

6.5 ORDERING CODE

ILA	25	A	Tr 30x6	C400	TS	SP	FC	
1	2	3	4	5	6	7	8.A	
gearbox ...								
9								
AC 3-phase motor 1.5 kW 4-pole 230/400 V 50 Hz IP 55 Ins. F								
10								

1	Actuator series ILA		
2	Actuator size 15, 25, 50, 100, 150, 200	pages 186 ... 189	
3	Type of linear drive screw A - acme screw B - ball screw	pages 186 ... 189	
4	Linear drive screw	pages 186 ... 189	
5	Stroke code		
6	Front attachment TS - ball joint TF - hinged head	pages 190 ... 193	
7	Rear attachment (without code) - pins SP - rear brackets	pages 190 ... 193	
8	Stroke end switches FCP - inductive proximity switches	page 194	
9	Input drive gearbox data		
10	Motor data		
11	Other specifications example: push rod in stainless steel AISI 304 example: lubricant for low temperature		
12	Filled in SELECTION DATA sheet	page 197	
13	Application layout		



APPLICATION: _____

REQUIRED STROKE: _____ mm

REQUIRED LINEAR SPEED: _____ mm/s _____ mm/min _____ m/min TIME TO PERFORM 1 STROKE: _____ s

STATIC LOAD: PULL: _____ N PUSH: _____ N at STROKE _____ mm

DYNAMIC LOAD: PULL: _____ N PUSH: _____ N at STROKE _____ mm

ACTUATOR SUBJECTED TO VIBRATIONS NOT SUBJECTED TO VIBRATIONS

OPERATING: _____ cycle / hour _____ working hours / day Notes: _____

REQUIRED LIFETIME: _____ cycle _____ hours _____ calendar days Notes: _____

ENVIRONMENT: TEMPERATURE _____ °C DUST HUMIDITY _____ % AGGRESSIVE AGENT _____

Acme screw actuators **ILA . A Series** Ball screw actuators **ILA . B Series**

Size: 15 25 50 100 150 200

1-start acme screw

ball screw with STANDARD lead

2-start acme screw

ball screw with LONG lead

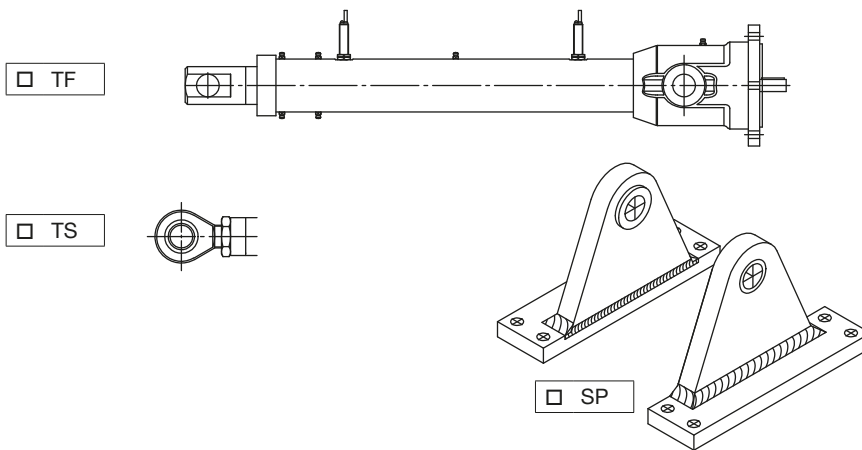

INPUT DRIVE _____

ELECTRIC MOTOR _____

ANTI-TURN DEVICE AR

SAFETY NUT MS

BELLOWS

PUSH ROD IN STAINLESS STEEL

OUTER TUBE IN STAINLESS STEEL

OTHER: _____

Acme screw actuators **ILA . A Series**

Ball screw actuators **ILA . B Series**

PRODUCT: _____

INPUT DRIVE

WITHOUT

ELECTRIC MOTOR

WITHOUT

Product serial number: _____ ; q.ty: _____

HINGED HEAD TF

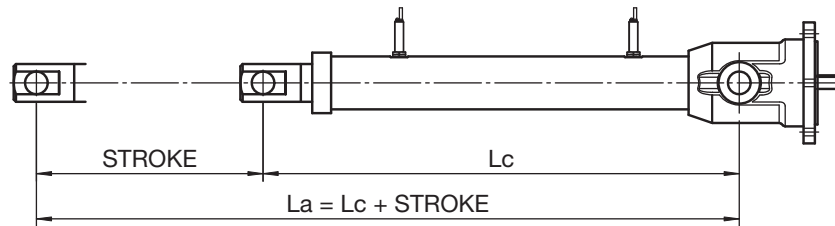

BALL JOINT TS

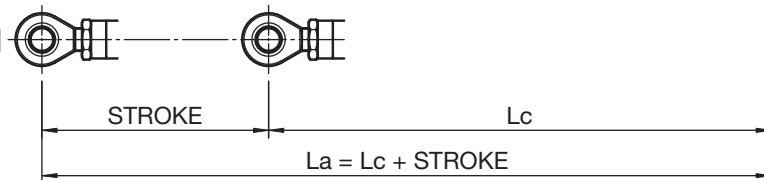

LINEAR ACTUATOR LENGTH

WORKING RANGE

RETRACTED ACTUATOR length: Lc = _____ mm
 EXTENDED ACTUATOR length: La = _____ mm
 STROKE (La - Lc): C = _____ mm

INTERNAL MECHANICAL STOP LIMIT

MIN. actuator length: _____ mm
 MAX. actuator length: _____ mm

Servomech. QMS

PASSED

Date: _____

Signature: _____

PROXIMITY STROKE END SWITCHES **FCP** □

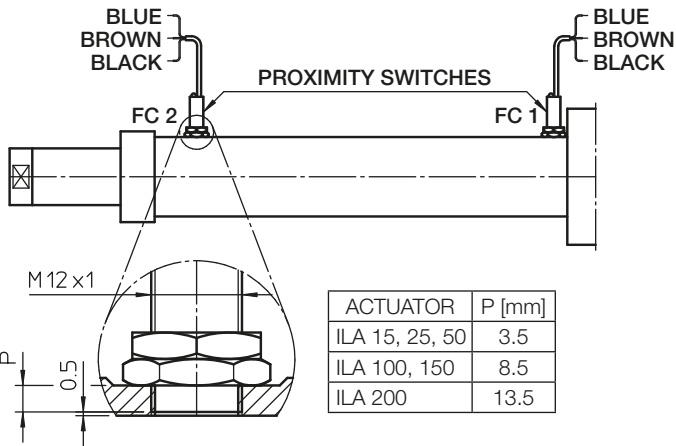

The PROXIMITY STROKE END SWITCHES **FCP** has proximity sensors FC 1 and FC 2.

- type: inductive, PNP
- contact: **normally CLOSED**
- supply voltage: (10 ... 30) V DC
- max. output current: 200 mA
- max. voltage drop (activated sensor): < 3 V (ref. 200 mA)

FC 1 - sensor for RETRACTED ACTUATOR position
 FC 2 - sensor for EXTENDED ACTUATOR position

SINGLE SENSOR WIRING:



WARNING!

1. The values **Lc** (RETRACTED ACTUATOR length), **La** (EXTENDED ACTUATOR length) and **C** (STROKE) are the extreme limit values.
2. **BEFORE** using the linear actuator:
 - verify the input shaft rotating direction and the push rod running direction;
 - make sure that the motor and the limit switches are correctly connected and that the right voltage is used.
3. Linear actuators equipped with brake motor supplied by SERVOMECH:
 - the brake is **NORMALLY CLOSED** (NEGATIVE action). When the power supply is switched off, the brake is engaged. The brake opens only when power is supplied;
 - if the brake is wired directly to the connecting pins of the terminal box, it does not require any power supply;
 - if the brake is wired separately, make sure that the correct voltage is used;
 - if the brake is equipped with hand release device, make sure that the brake is engaged before starting the linear actuator.
4. **Alignment check:** the load must be in line with the actuator. No off-set or radial loads are allowed.

NOTE: _____

INPUT DRIVE LUBRICANT: _____
 BEARINGS LUBRICANT: _____
 SCREW – NUT LUBRICANT: _____

SERVOMECH Linear Actuators

7.1 AC 3-phase electric motors

AC asynchronous 3-phase motors, totally enclosed, fan-cooled, with or without brake, made by Italian manufacturers according to IEC standards.

Dynamically balanced rotor, high pressure die-casting housing with fins in aluminium alloy.

Standard: insulation class F, protection class IP 55.

On request: insulation class H and/or higher protection class.

On request: tropicalised winding for ambient with high temperature and humidity.

On request: thermal protection devices.

On request: brake motor.

For more technical information and details, please, refer to manufacturers catalogue.

7.2 AC 1-phase electric motors

AC asynchronous 1-phase motors, totally enclosed, fan-cooled, with or without brake, made by an Italian manufacturers according to IEC standards.

Dynamically balanced rotor, high pressure die-casting housing with fins in aluminium alloy.

Balanced stator windings for clockwise and anti-clockwise running without vibrations. Condenser supplied with motor, with increased capacity for higher starting torque.

Standard: insulation class F, protection class IP 55.

On request: insulation class H and/or higher protection class.

On request: thermal protection devices.

Performances with 50 Hz 230 V power supply:

POWER [kW] N° OF POLES	NOMINAL TORQUE [Nm]	NOMINAL CURRENT [A]	STARTING TORQUE [Nm]	STARTING CURRENT [A]	COND. [μF]	MASS [kg] ¹⁾	MASS [kg] ²⁾
0.09 kW 4-pole	0.64	1.6	1.03	1.9	12.5	3	3.7
0.12 kW 2-pole	0.43	2.6	0.71	3.7	12.5	3	3.7
0.18 kW 4-pole	1.31	1.9	1.37	3.2	16	4.2	5.5
0.25 kW 2-pole	0.84	2.1	0.97	6.3	20	5	5.9
0.37 kW 4-pole	2.64	2.8	2.82	6.1	25	7.2	7.3
0.55 kW 2-pole	1.88	3.9	1.66	11.2	30	7	7.8

1) mass of motor WITHOUT brake

2) mass of motor WITH brake

MOTOR BRAKE: normally closed mechanical brake, activated by a direct current electromagnet 205 V DC, powered by a rectifier in the terminal box (input voltage 230 V AC - output voltage 205 V DC). Brake powered separately: wire terminals into the terminal box.

MOTOR	BRAKING TORQUE [Nm]	CURRENT [A]
0.09 kW 4-pole	1.8	0.05
0.12 kW 2-pole	1.8	0.05
0.18 kW 4-pole	4	0.09
0.25 kW 2-pole	4	0.09
0.37 kW 4-pole	4	0.09
0.55 kW 2-pole	4	0.09

AC 1-phase motors for 60 Hz 110 V are available on request.

7.3 DC electric motors

DC motors with high coercive ferrite permanent magnet field, without fan, made by Italian manufacturers.

Standard: insulation class F, protection class IP 54.

On request: higher protection class.

On request: motor without fan with brake.

SERVOMECH Linear Actuators

Performances at nominal voltage:

MOTOR (nominal power)		100 W	150 W	300 W	500 W	750 W
Nominal voltage	[V]	24	24	24	24	90
Nominal speed	[rpm]	3000	3000	3000	3000	3000
Nominal torque	[Nm]	0.32	0.48	0.96	1.6	2.4
Max. torque	[Nm]	1.6	2.4	4.8	5.7	12
Nominal current	[A]	5.5	8.3	15.6	25	10.6
Max. current	[A]	27.7	41.7	78	89	53
Resistance	[Ω]	0.4	0.29	0.16	0.1	0.71
Inductance	[mH]	0.8	0.73	0.32	0.13	4.6
Mass of motor WITHOUT brake	[kg]	2.9	3.5	5.3	8	9.4

MOTOR BRAKE: normally closed mechanical brake, activated by electromagnet. Brake powered separately, with wire terminals into the terminal box.

MOTOR	BRAKING TORQUE [Nm]	VOLTAGE [V]	CURRENT [A]
100 W	1.7	24 ... 180	0.5
150 W	1.7		0.5
300 W	1.7		0.5
500 W	2		0.7
750 W	8		1

Motor dimensions:

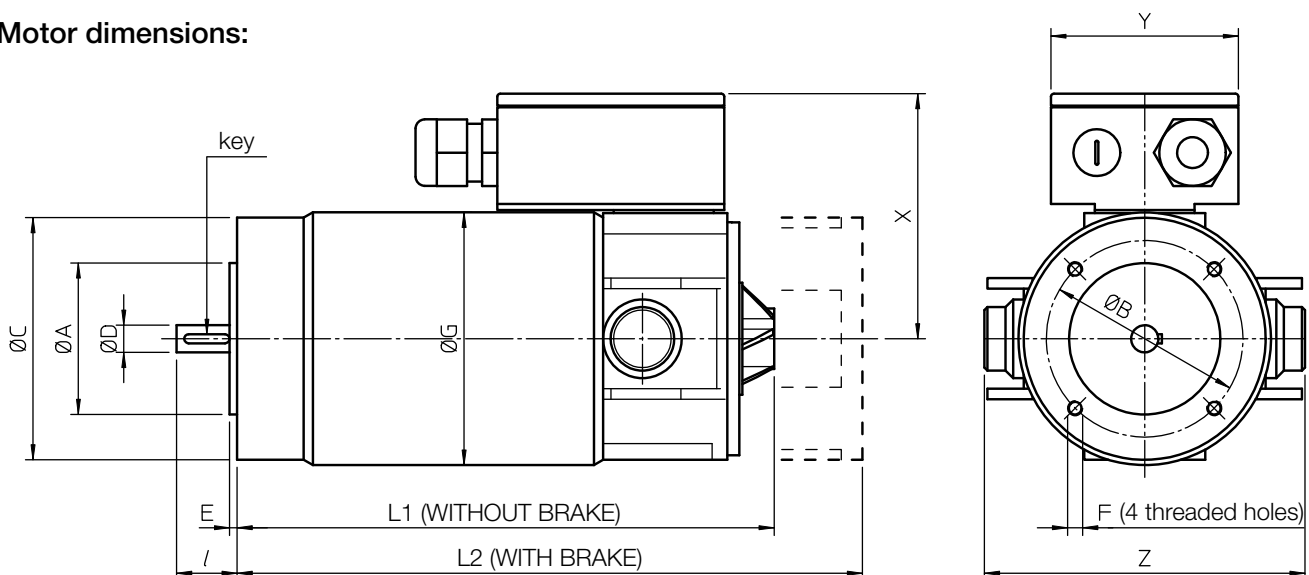

MOTOR	Ø A	Ø B	Ø C	Ø D	E	F	Ø G	l	key	L1	L2	X	Y	Z
100 W	50	65	80	9	2.5	M5	84	20	3×3×15	144	185	80	62	107
150 W	50	65	80	9	2.5	M5	84	20	3×3×15	177	218	80	62	107
300 W	60	75	90	11	2.5	M5	84	23	4×4×15	229	270	80	62	107
500 W	70	85	105	14	2.5	M6	84	30	5×5×20	322	364	80	62	107
750 W	80	100	120	19	3	M6	120	40	6×6×30	317	359	118	94	140

7.4 Brake motor: when it is required

- Ball screw linear actuators UBA Series: supplied as standard
- Ball screw linear actuators BSA Series and CLB series: on request, anyway it is always recommended
- Acme screw linear actuators UAL Series: on request
 - to help the actuator in stopping
 - to ensure positioning accuracy
 - to sustain the static load when the self-locking coefficient > 0.3
- Acme screw linear actuator ATL Series, CLA Series and TMA Series: on request
 - to ensure positioning accuracy
 - to sustain the static load when the self-locking coefficient > 0.3

SERVOMECH Linear Actuators

8.1 Product nameplate

Every SERVOMECH linear actuator is provided with a nameplate, as shown below, which allows the product identification and gives technical information about the product.

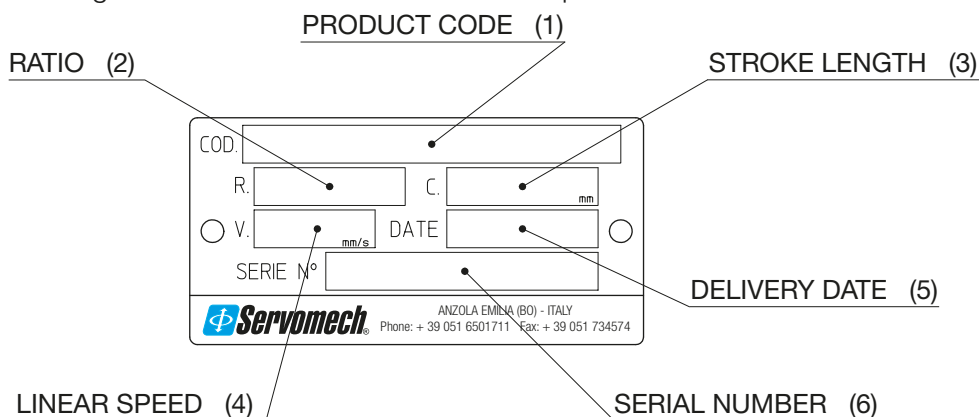

- 1) **Product code:** is an alphanumeric code stating the type, size, ratio, version and stroke end switches of the linear actuator;
- 2) **Ratio:** is the ratio of the input drive;
- 3) **Stroke length:** is the stroke length in millimetres achievable by the actuator;
- 4) **Linear speed:** is the linear speed expressed in mm/s when the actuator is provided with electric motor; for an actuator without motor, this field is blank;
- 5) **Delivery date:** is the week/year of assembly (example: 30/13 = week 30 / year 2013) which usually coincides with the delivery date; this date is considered as reference for the warranty period;
- 6) **Serial number:** is the identification number of the actuator which identifies the exact design of the product even after a long time; the serial number is the essential reference for spare part orders.

8.2 Conditions on delivery

If not otherwise specific required, SERVOMECH linear actuators are supplied with the following conditions:

- lubrication: according to the tables on page 204 and 205; in case of particular application requirements (ambient temperature, food industry, environment with ionizing radiations, environment that requires biodegradable lubricants), a suitable lubricant can be supplied for the specific environment (for more details, please, contact SERVOMECH); on request, actuators can be supplied with the lubricant agreed with the customer;
- painting: all outer surfaces of the actuator that can be subject to rust are painted with 1 epoxy coating blue colour RAL 5010; on request, the painting can be done with specific colours and specification agreed with the customer with separate quotation;
- shaft protection: input shafts are protected with removable plastic covers;
- packaging: the kind of packaging is agreed with the customer based on quantity of the products, final destination and means of transport; packaging is not included in selling price.

8.3 Installation - Maintenance - Lubrication

Transport and handling

It is recommended to handle the linear actuators with particular care and attention during transportation and handling to avoid damage on mechanical parts and/or accessories and to prevent any risk to the personnel in charge of such operations. The package should be handled in the safest way during transport and handling. In case of doubt, please, contact SERVOMECH S.p.A. to get the correct instructions and prevent any kind of damage!

Storage

During storage, linear actuators shall be protected against atmospheric agents and dust or other pollution to the push rod, moving parts and attachments.

In case of long storage periods, for example more than 6 months, it is necessary to move the input shafts to avoid damaging of the ring seals. Furthermore, all non-painted parts should be maintained properly lubricated to prevent oxidation.

Installation

Linear actuators must be installed to work with push or pull axial load only, lateral and radial loads are not allowed. The front and rear fixing attachments must be aligned.

The installation of two or more actuators, connected to work in synchronized movement, requires particular attention on the following two aspects:

- alignment of the load support points;
- use of connecting shaft and couplings with high torsional rigidity to ensure a perfect synchronism of all points of support.

Commissioning and use

SERVOMECH linear actuators are supplied with the type and quantity of lubricant specified in the relevant table.

Before actuator commissioning and activation, the following checks must be carried out:

- verify the motor shaft turning direction and the related push rod travelling direction;
- verify the stroke end switches position: the given limits cannot be exceeded;
- check the right connection of the electric motor (direction of rotation and motor supply voltage) and, if it is the case, of the mechanical transmission.

During commissioning and tests, do not exceed the **ACTUATOR DUTY CYCLE PERMISSIBLE F_i [%]**! Any misuse can cause over-heating and premature damage.

Maintenance

Scheduled maintenance shall be carried out on linear actuators depending on the relevant use and environment conditions.

The gearbox of the linear actuator is long-life lubricated. Additional lubrication should be done only in case of verified leakage of lubricant.

For further information about installation and maintenance, please refer to the linear actuators Use and Maintenance Manual.

8.4 General terms of sale

The products are supplied by SERVOMECH S.p.A. according to the **General terms of sale** available on the web-site www.servomech.it or upon request to the sales dept. (sales@servomech.it). The acceptance of our order confirmation implies also the acceptance of our **General terms of sale**.

SERVOMECH Linear Actuators

8.5 Lubricants

Linear actuators ATL Series

ACTUATOR	INPUT DRIVE		LINEAR DRIVE		
				for actuator C100	for each additional 100 mm of stroke
ATL 20	grease: AGIP Grease SLL 00	0.03 kg	grease: AGIP Grease SM 2	0.02 kg	0.02 kg
ATL 25		0.03 kg		0.03 kg	0.025 kg
ATL 28		0.03 kg		0.03 kg	0.025 kg
ATL 30		0.04 kg		0.04 kg	0.03 kg
ATL 40		0.05 kg		0.05 kg	0.04 kg
ATL 50		0.35 kg		0.065 kg	0.05 kg
ATL 63		0.75 kg		0.1 kg	0.08 kg
ATL 80		1.5 kg		0.15 kg	0.12 kg
ATL 100		2.5 kg		0.20 kg	0.13 kg
ATL 125		5.2 kg		0.25 kg	0.15 kg

Linear actuators BSA Series

ACTUATOR	INPUT DRIVE		LINEAR DRIVE		
				for actuator C100	for each additional 100 mm of stroke
BSA 20	grease: AGIP Grease SLL 00	0.03 kg	grease: LUBCON Thermoplex ALN 1001	0.01 kg	0.01 kg
BSA 25		0.03 kg		0.015 kg	0.012 kg
BSA 28		0.03 kg		0.015 kg	0.012 kg
BSA 30		0.04 kg		0.02 kg	0.015 kg
BSA 40		0.05 kg		0.025 kg	0.02 kg
BSA 50		0.35 kg		0.04 kg	0.03 kg
BSA 63		0.75 kg		0.06 kg	0.05 kg
BSA 80		1.5 kg		0.1 kg	0.06 kg
BSA 100		2.5 kg		0.14 kg	0.07 kg
BSA 125		5.2 kg		0.18 kg	0.09 kg

Linear actuators CLA Series

ACTUATOR	INPUT DRIVE		LINEAR DRIVE		
				for actuator C100	for each additional 100 mm of stroke
CLA 30	grease: AGIP Grease SM 2	0.04 kg	grease: AGIP Grease SM 2	0.04 kg	0.03 kg
CLA 40		0.05 kg		0.05 kg	0.04 kg
CLA 50	grease: AGIP Grease SLL 00	0.05 kg		0.065 kg	0.05 kg

Linear actuators CLB Series

ACTUATOR	INPUT DRIVE		LINEAR DRIVE		
				for actuator C100	for each additional 100 mm of stroke
CLB 30	grease: AGIP Grease SM 2	0.04 kg	grease: LUBCON Thermoplex ALN 1001	0.02 kg	0.015 kg
CLB 40		0.05 kg		0.025 kg	0.02 kg
CLB 50	grease: AGIP Grease SLL 00	0.05 kg		0.04 kg	0.03 kg

SERVOMECH Linear Actuators

8.5 Lubricants

Linear actuators UAL Series

ACTUATOR	BEARINGS		LINEAR DRIVE		
				for actuator C100	for each additional 100 mm of stroke
UAL 1	grease: SHELL Gadus S2 V100 2	0.03 kg	grease: AGIP Grease SM 2	0.02 kg	0.02 kg
UAL 2		0.03 kg		0.03 kg	0.025 kg
UAL 3		0.03 kg		0.04 kg	0.025 kg
UAL 4		0.04 kg		0.05 kg	0.03 kg
UAL 5		0.05 kg		0.065 kg	0.05 kg

Linear actuators UBA Series

ACTUATOR	BEARINGS		LINEAR DRIVE		
				for actuator C100	for each additional 100 mm of stroke
UBA 1	grease: SHELL Gadus S2 V100 2	0.03 kg	grease: LUBCON Thermoplex ALN 1001	0.01 kg	0.01 kg
UBA 2		0.03 kg		0.015 kg	0.012 kg
UBA 3		0.03 kg		0.02 kg	0.015 kg
UBA 4		0.04 kg		0.025 kg	0.02 kg
UBA 5		0.05 kg		0.04 kg	0.03 kg

Attuatori lineari Serie TMA

ACTUATOR	INPUT DRIVE		LINEAR DRIVE		
				for actuator C500	for each additional 100 mm of stroke
TMA 15	grease: AGIP Grease SM 2	0.1 kg	grease: SHELL Gadus S2 U460L 2	0.13 kg	0.02 kg
TMA 25		0.5 kg		0.18 kg	0.03 kg
TMA 50		1 kg		0.26 kg	0.03 kg
TMA 100		2 kg		0.35 kg	0.05 kg
TMA 150		3 kg		0.4 kg	0.05 kg
TMA 200		5.2 kg		0.5 kg	0.06 kg

Linear actuators ILA . A Series

ACTUATOR	BEARINGS		LINEAR DRIVE		
				for actuator C100	for each additional 100 mm of stroke
ILA 15 A	grease: SHELL Gadus S2 V100 2	0.1 kg	grease: AGIP Grease SM 2	0.05 kg	0.03 kg
ILA 25 A		0.2 kg		0.065 kg	0.04 kg
ILA 50 A		0.4 kg		0.1 kg	0.05 kg
ILA 100 A		0.8 kg		0.15 kg	0.08 kg
ILA 150 A		1 kg		0.18 kg	0.08 kg
ILA 250 A		1.8 kg		0.25 kg	0.1 kg

Linear actuators ILA . B Series

ACTUATOR	BEARINGS		LINEAR DRIVE		
				for actuator C100	for each additional 100 mm of stroke
ILA 15 B	grease: SHELL Gadus S2 V100 2	0.1 kg	grease: LUBCON Thermoplex ALN 1001	0.05 kg	0.03 kg
ILA 25 B		0.2 kg		0.065 kg	0.04 kg
ILA 50 B		0.4 kg		0.1 kg	0.05 kg
ILA 100 B		0.8 kg		0.15 kg	0.08 kg
ILA 150 B		1 kg		0.18 kg	0.08 kg
ILA 250 B		1.8 kg		0.25 kg	0.1 kg

SERVOMECH product range includes also:

Acme screw jacks

**MA Series
travelling screw (Mod.A)**

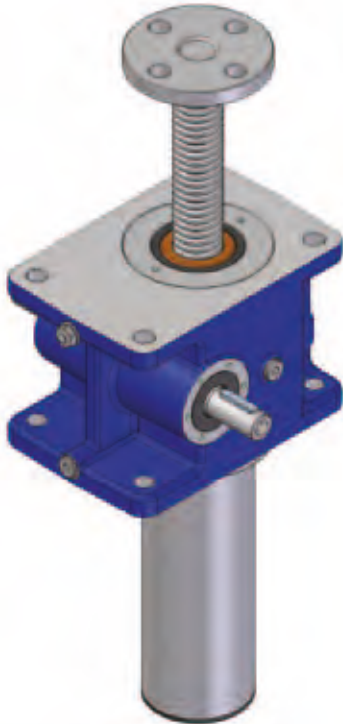

- max. duty cycle:
travelling screw: 40 % over 10 min (30 % over 1 hour)
travelling nut: 30 % over 10 min (20 % over 1 hour)
- load capacity from 5 kN to 350 kN
- 8 sizes
- acme screw diameter from 18 mm to 100 mm
- 1-, 2-, 3- or 4-start acme screw
- input speed up to 3 000 rpm
- linear speed up to 300 mm/s
- worm gearbox lubricated with synthetic oil

**MA Series
travelling nut (Mod.B)**

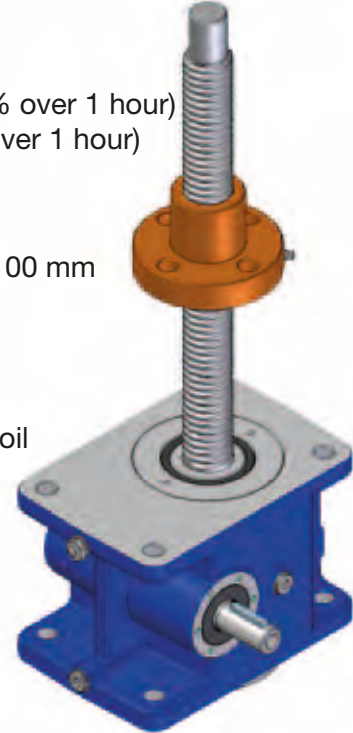

**SJ Series
travelling screw (Mod.A)**

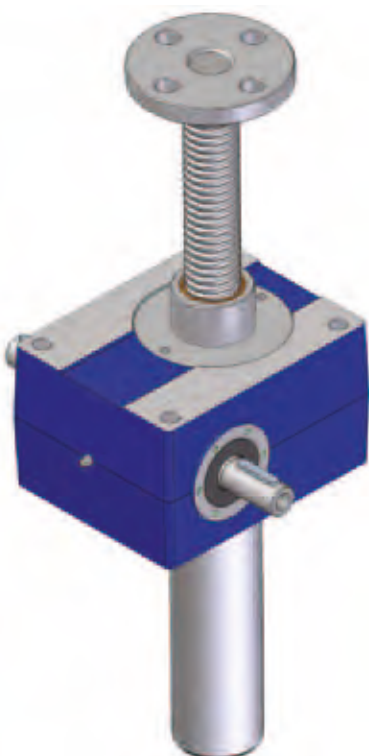

- max. duty cycle:
30 % over 10 min (20 % over 1 hour)
- load capacity from 5 kN to 1 000 kN
- 14 sizes
- acme screw diameter from 18 mm to 160 mm
- 1- or 2-start acme screw
- input speed up to 1 500 rpm
- linear speed up to 80 mm/s
- gearbox lubrication with synthetic grease

**SJ Series
travelling nut (Mod.B)**

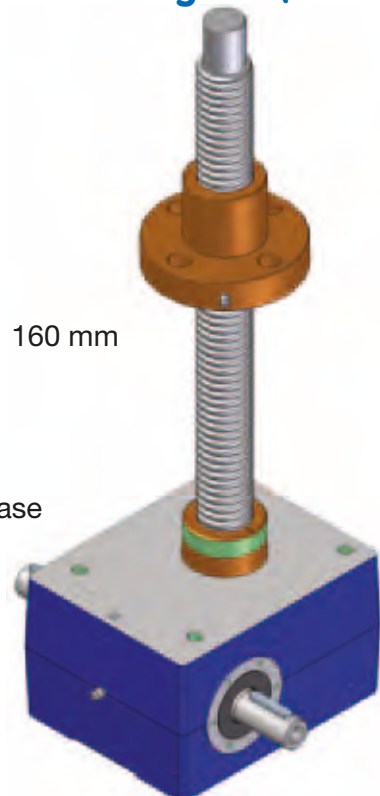

SERVOMECH product range includes also:

Ball screw jacks

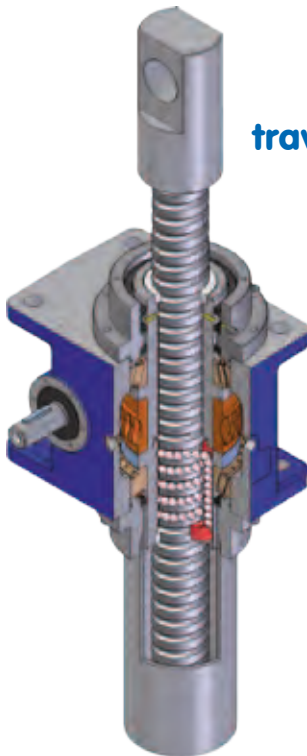

**MA . BS Series
travelling screw (Mod.A)**

- High performances, accuracy and stiffness
Duty cycle up to 100 % (continuous work)
- Patented lubrication system
ball nut with abundant grease reserve
- Load capacity from 5 kN to 350 kN
- 8 sizes
- Ball screw diameter from 16 mm to 100 mm
- Input speed up to 3 000 rpm
- Linear speed up to 285 mm/s

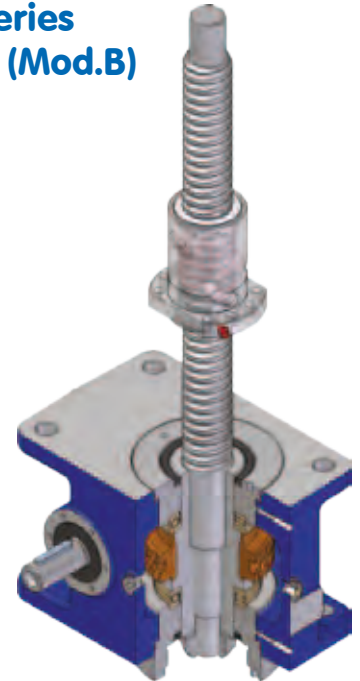

**MA . BS Series
travelling nut (Mod.B)**

**HS Series
travelling nut (Mod.B)**

- High speed
Duty cycle up to 100 %
- 6 sizes
- Ball screw diameter
from 25 mm a 80 mm
- Input speed
up to 3 000 rpm
- Linear speed up to 2 m/s

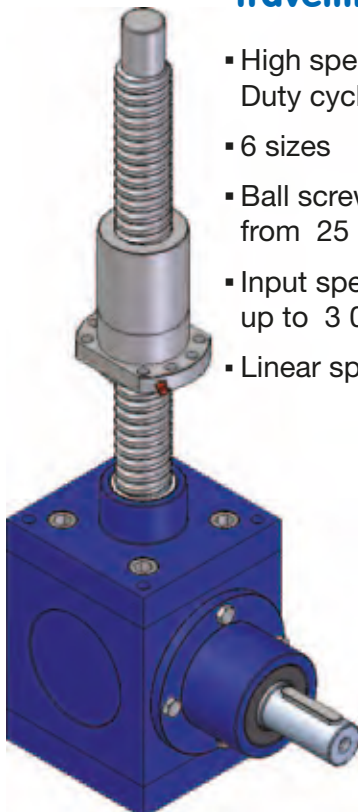

**SJ . BS Series
travelling nut (Mod.B)**

- Standard performances
Duty cycle up to 70 %
- Load capacity
from 5 kN to 300 kN
- 9 sizes
- Ball screw diameter
from 16 mm to 100 mm
- Input speed
up to 1 500 rpm
- Linear speed
up to 140 mm/s

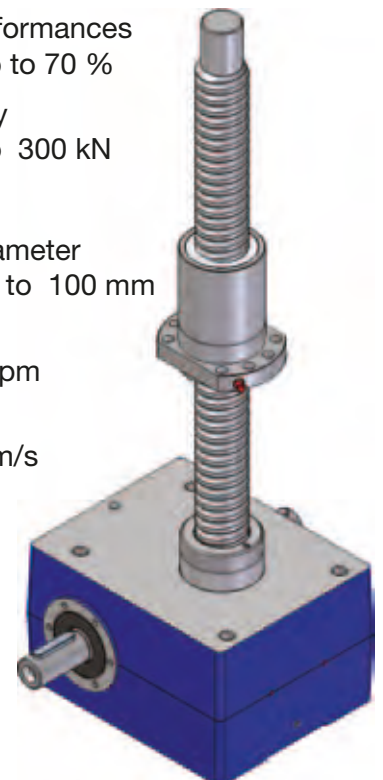

SERVOMECH product range includes also:

Bevel gearboxes

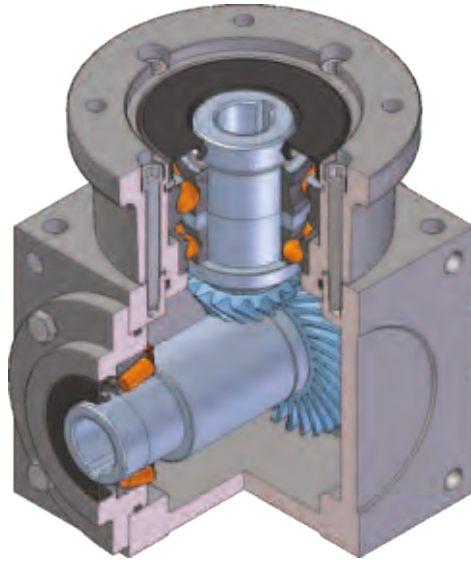

- Cubic form housing with 6 machined sides
- Bevel gears made in alloy steel, GLEASON spiral tooth profile
- 6 sizes
- Ratio: 1 : 1, 1 : 1.5, 1 : 2, 1 : 3, 1 : 4
- Max. input speed: 3 000 rpm
- Standard lubrication: grease

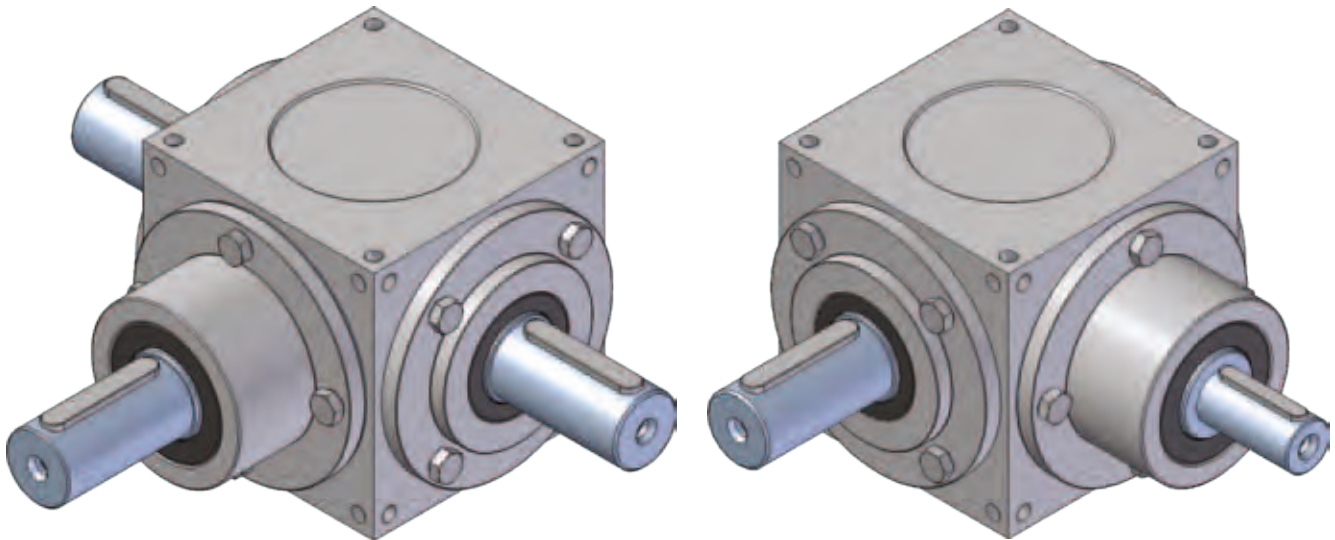

SERVOMECH product range includes also:

Ball screws and nuts

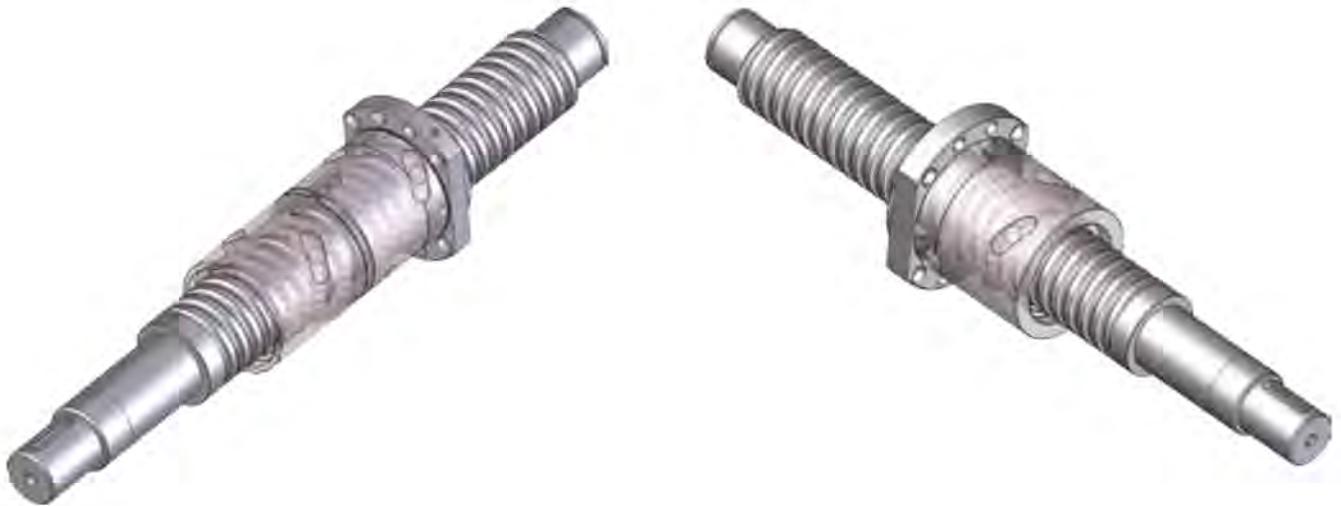

- Whirled ball screws, accuracy grade IT3 or IT5
- Rolled ball screws, accuracy grade IT7
- Ball nuts with DIN 69051 flange or cylindrical flange
- Backlash-free or preloaded ball nuts

Italian technology

own production

entire in-house manufacturing

Ask for technical catalogues at:
info@servomech.it

SERVOMECH product range includes also:

Acme screw jacks

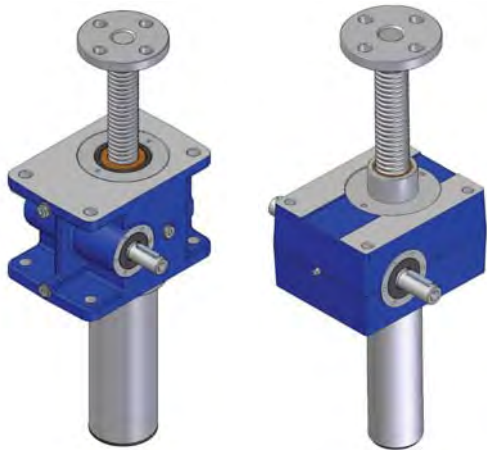

Ball screw jacks

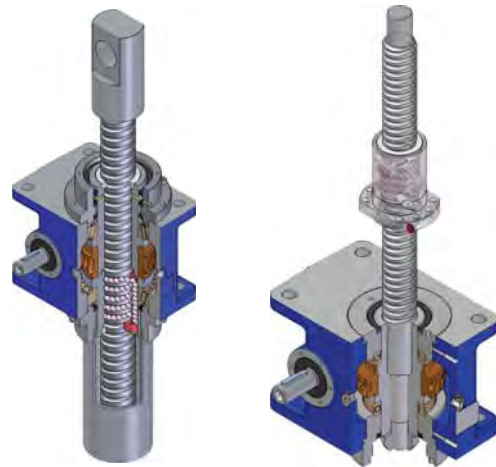

Bevel gearboxes

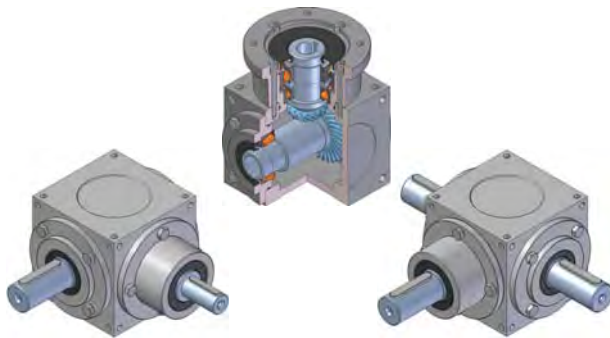

Ball screws and nuts



To receive a free copy of the catalogue, please, contact:



+ 39 051 6501711



+ 39 051 734574

info@servomech.it

 **Servomech**[®]
new ideas in linear motion

SERVOMECH s.p.a.
Via M. Calari 1, 40011 Anzola dell'Emilia (BOLOGNA) ITALY
Phone: + 39 051 6501711 Fax: + 39 051 734574
www.servomech.it e-mail: info@servomech.it

