

**Linear actuators CLA Series and CLB Series**

3

CLA-CLB Series, size 30 - 40

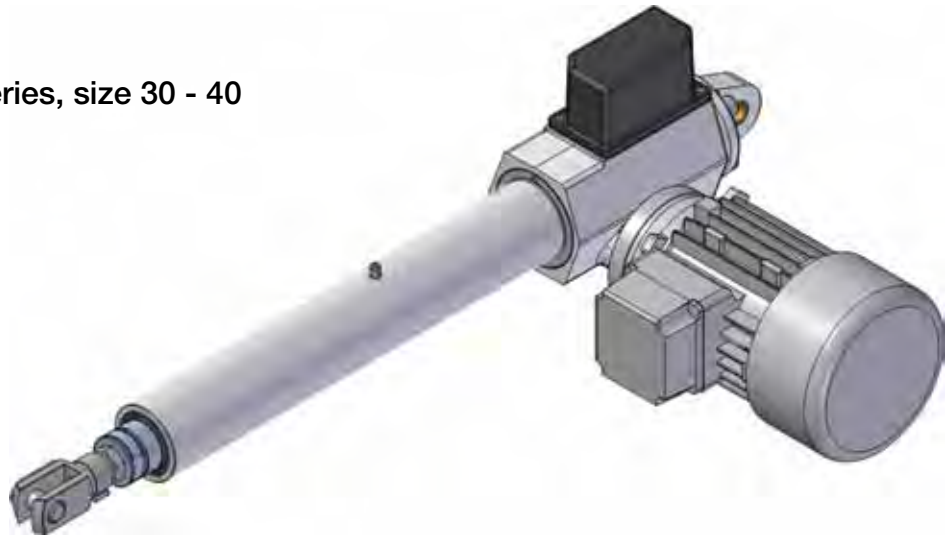

CLA-CLB Series, size 50

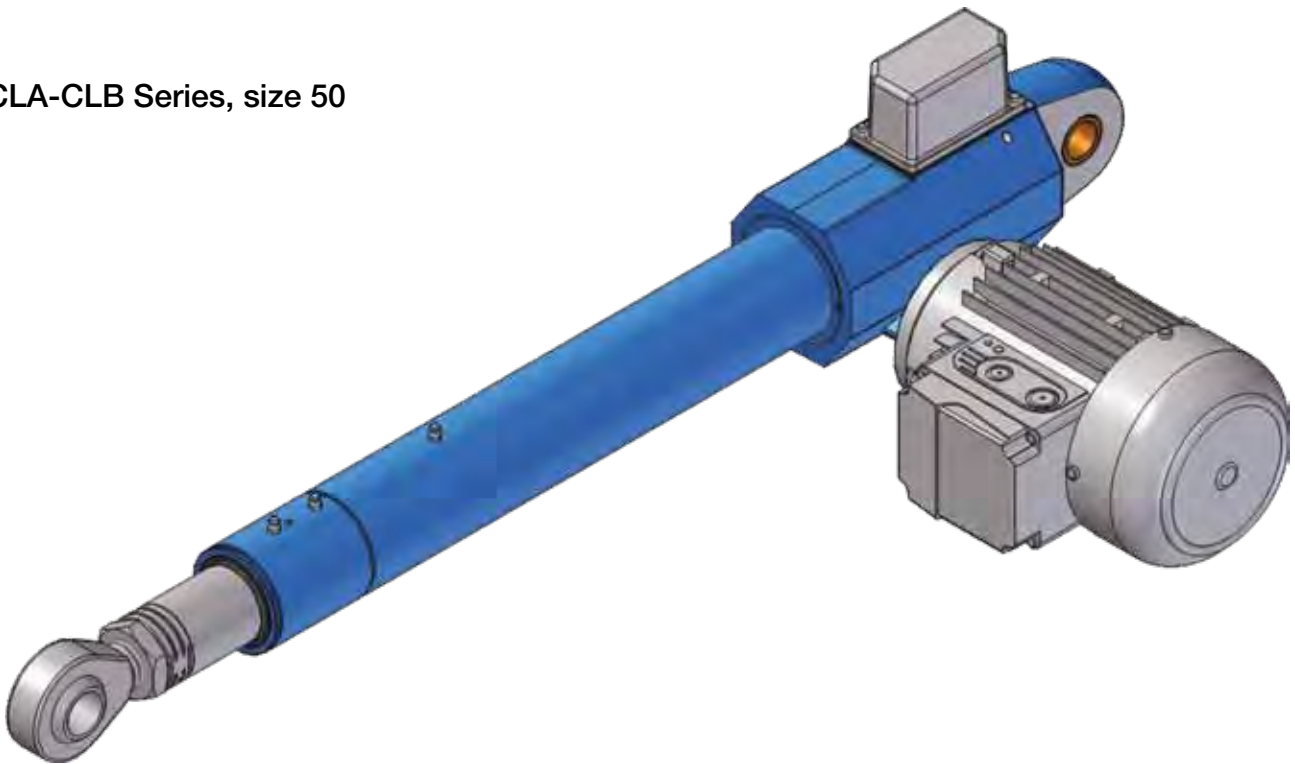

## Linear actuators CLA Series and CLB Series

### 3.1 MANUFACTURING FEATURES

**Input drive:** worm gear - precision helical wheel, geometric design for high performance, involute profile ZI (UNI 4760 : Part 4), low angular backlash. Worm in case hardened steel 20 MnCr 5 (UNI EN 10084), with thread and input shafts ground. Helical wormwheel in bronze EN 1982 – CuSn12-C.

**Housing:** designed and manufactured in monobloc form to obtain a compact body able to sustain heavy axial loads and high machining accuracy. High quality materials are used:

- castings in aluminium alloy EN 1706 AC-ALSi6Cu4
- castings in grey cast iron EN-GJL-250 (UNI EN 1561).

**Acme screw:**

- ISO trapezoidal thread ISO 2901 ... ISO 2904
- material: steel C 43 (UNI 7847)
- rolled or whirled
- subjected to straightening, to ensure accurate alignment in operation
- max. pitch error  $\pm 0.05$  mm over 300 mm length

**Bronze nut:**

- ISO trapezoidal thread ISO 2901 ... ISO 2904
- material: bronze EN 1982 – CuAl9-C (1-start thread)
- material: bronze EN 1982 – CuSn12-C (multiple start thread)
- max. axial backlash for new nut (0.10 ... 0.12) mm

**Outer tube:**

- material: aluminium alloy EN AW-6060 thick cold-drawn tube anodized ARC 20 (UNI 4522/66) inner diameter tolerance ISO H9
- steel St 52.2 (DIN 2391) cold-drawn tube inner diameter tolerance ISO H10 ... H11

**Bearings:**

- on motor axis: radial ball bearings
- on actuator axis: radial ball bearings or angular contact ball bearings, to avoid axial backlash and to assure high push-pull load capacity

**Front attachment:**

- standard – with threaded hollow bore, in stainless steel AISI 303 or steel C 43 (UNI 7847)

**Rear bracket:**

- in aluminium alloy for CLA-CLB 30, 40
- in grey cast iron for CLA-CLB 50
- pin in stainless steel AISI 303

**Electric stroke end switches FC:**

- cam-operated electric switches
- cover in thermoplastic material for CLA-CLB 30 and 40, in aluminium alloy for CLA-CLB 50
- drive transmission in brass OT 58 (UNI 5705/65)

**Ball screw:**

- designed and manufactured by SERVOMECH
- rolled and hardened material: steel 42 CrMo 4 (UNI EN 10083) accuracy grade: ISO IT 7
- hardened and machined material: steel 42 CrMo 4 (UNI EN 10083) accuracy grade: ISO IT 5

**Ball nut:**

- designed and manufactured by SERVOMECH
- material: steel 18 NiCrMo 5 (UNI EN 10084), case hardened
- max. axial backlash (0.07 ... 0.08) mm
- on request, ball nut with ZERO backlash or pre-loaded using selected diameter balls

**Push rod:**

- material: steel St 52 (DIN 2391) thick tube chrome-plated, min. chrome thickness 5/100 mm inner diameter tolerance ISO f7
- push rod in stainless steel INOX AISI 304 or special stainless steel on request

## Linear actuators CLA Series

### 3.2 TECHNICAL DATA - acme screw linear actuators CLA Series

SIZE		CLA 30	CLA 40	CLA 50	
Push rod diameter	[mm]	35	40	50	
Outer tube diameter	[mm]	55	60	70	
Front attachment diameter	[mm]	14	20	30	
Rear attachment diameter	[mm]	14	20	30	
Attachment for IEC standard motor (flange and hollow shaft)		63 B14	71 B14	71 B14	
Attachment for IEC standard motor (flange adapter + coupling)		—	—	80 B14	
Max. dynamic load	[N]	10 000	12 000	25 000	
Max. static load	pull [N]	10 000	12 000	25 000	
	push [N]	12 000	15 000	25 000	
Ratio	RV	1 : 4 (4 : 16)	1 : 5 (4 : 20)	1 : 5 (4 : 20)	
	RN	1 : 16 (2 : 32)	1 : 20	1 : 20	
	RL	1 : 24	1 : 25	1 : 25	
	RXL	1 : 34	1 : 55	1 : 55	
1-start acme screw		Tr 18×4	Tr 22×5	Tr 30×6	
Linear travel [mm] for 1 input shaft revolution	Ratio				
	RV1	1	1	1.2	
	RN1	0.25	0.25	0.3	
	RL1	0.17	0.2	0.24	
	RXL1	0.12	0.09	0.11	
2-start acme screw		Tr 18×8 (P4)	Tr 22×10 (P5)	Tr 30×12 (P6)	
Linear travel [mm] for 1 input shaft revolution	Ratio				
	RV2	2	2	2.4	
	RN2	0.5	0.5	0.6	
	RL2	0.33	0.4	0.28	
	RXL2	0.24	0.18	0.22	
Mass (actuator 100 mm stroke length, without motor, with lubricant)		[kg]	3.8	6.5	16
Extra-mass for each additional 100 mm stroke length		[kg]	0.8	0.8	2

## Linear actuators CLB Series

### 3.2 TECHNICAL DATA - ball screw linear actuators CLB Series

SIZE		CLB 30	CLB 40	CLB 50	
Push rod diameter	[mm]	35	40	50	
Outer tube diameter	[mm]	55	60	70	
Front attachment diameter	[mm]	14	20	30	
Rear attachment diameter	[mm]	14	20	25	
Attachment for IEC standard motor (flange and hollow shaft)		63 B14	71 B14	71 B14	
Attachment for IEC standard motor (flange adapter + coupling)		—	—	80 B14	
Max. dynamic load	[N]	9 000	12 000	25 000	
Max. static load	pull [N]	10 000	12 000	25 000	
	push [N]	12 000	15 000	25 000	
Ratio	RV	1 : 4 (4 : 16)	1 : 5 (4 : 20)	1 : 5 (4 : 20)	
	RN	1 : 16 (2 : 32)	1 : 20	1 : 20	
	RL	1 : 24	1 : 25	1 : 25	
	RXL	1 : 34	1 : 55	1 : 55	
Ball screw (STANDARD)	Diameter × Lead		20×5	25×6	32×10
	Ball	[mm]	3.175 (1/8 ")	3.969 (5/32 ")	6.350 (1/4 ")
	N° of circuits		3	3	4
	Dynamic load C <sub>a</sub>	[N]	12 000	17 400	41 800
	Static load C <sub>0a</sub>	[N]	21 200	30 500	73 000
Linear travel [mm] for 1 input shaft revolution	Ratio	RV1	1.25	1.2	2
		RN1	0.31	0.3	0.5
		RL1	0.24	0.24	0.4
		RXL1	0.15	0.11	0.18
Mass (actuator 100 mm stroke length, without motor, with lubricant)		[kg]	3.8	6.5	19
Extra-mass for each additional 100 mm stroke length		[kg]	0.8	0.9	2

#### ON REQUEST

Ball screw (Diameter × Lead)		20×10	25×10	32×20
Ball	[mm]	3.175 (1/8 ")	3.969 (5/32 ")	6.35 (1/4 ")
N° of circuits		3	3	3
Dynamic load C <sub>a</sub>	[N]	12 900	18 000	32 200
Static load C <sub>0a</sub>	[N]	23 500	33 000	53 000

**NOTE:** When these ball screws are used, the actuator length will be increased.  
Please, contact SERVOMECH to get information about the exact length.

## Linear actuators CLA Series

ACME SCREW LINEAR ACTUATORS CLA Series with AC 3-PHASE MOTOR  
 PERFORMANCE with: Duty Cycle  $F_i = 30\%$  over 10 min at ambient temperature 25 °C

LINEAR SPEED [mm/s]	DYNAMIC LOAD [N]	RATIO	MOTOR: POWER [kW] — N° of POLES SPEED [rpm]	SELF-LOCKING COEFFICIENT
<b>CLA 30</b>				
46	2500 <sup>1)</sup>	RV1	0.25 kW 2-pole 2800	0.25
23	5200 <sup>1)</sup>	RN2	0.25 kW 2-pole 2800	0.28
15	6700 <sup>1)</sup>	RL2	0.25 kW 2-pole 2800	0.22
11	8500 <sup>1)</sup>	RXL2	0.25 kW 2-pole 2800	0.18
7.5	9700 <sup>1)</sup>	RL1	0.25 kW 2-pole 2800	0.16
5.5	10000 <sup>2)</sup>	RXL1	0.25 kW 2-pole 2800	0.13
4	10000 <sup>2)</sup>	RL1	0.18 kW 4-pole 1400	0.16
2.7	10000 <sup>2)</sup>	RXL1	0.18 kW 4-pole 1400	0.13
<b>CLA 40</b>				
46	5400 <sup>1)</sup>	RV1	0.55 kW 2-pole 2800	0.26
23	10500 <sup>1)</sup>	RN2	0.55 kW 2-pole 2800	0.25
18	12000 <sup>2)</sup>	RL2	0.55 kW 2-pole 2800	0.24
11	12000 <sup>2)</sup>	RN1	0.55 kW 2-pole 2800	0.18
8.5	12000 <sup>2)</sup>	RXL2	0.55 kW 2-pole 2800	0.17
5.5	12000 <sup>2)</sup>	RN1	0.37 kW 4-pole 1400	0.18
4.5	12000 <sup>2)</sup>	RL1	0.37 kW 4-pole 1400	0.17
2.1	12000 <sup>2)</sup>	RXL1	0.37 kW 4-pole 1400	0.08
<b>CLA 50</b>				
56	9300 <sup>1)</sup>	RV1	1.1 kW 2-pole 2800	0.24
28	17900 <sup>1)</sup>	RN2	1.1 kW 2-pole 2800	0.23
22	20800 <sup>1)</sup>	RL2	1.1 kW 2-pole 2800	0.22
14	25000 <sup>2)</sup>	RN1	1.1 kW 2-pole 2800	0.16
11	25000 <sup>2)</sup>	RL1	1.1 kW 2-pole 2800	0.15
7	25000 <sup>2)</sup>	RN1	0.75 kW 4-pole 1400	0.16
5.5	25000 <sup>2)</sup>	RL1	0.75 kW 4-pole 1400	0.15
2.5	25000 <sup>2)</sup>	RXL1	0.37 kW 4-pole 1400	0.08

ACME SCREW LINEAR ACTUATORS CLA Series with AC 1-PHASE MOTOR  
 PERFORMANCE with: Duty Cycle  $F_i = 30\%$  over 10 min at ambient temperature 25 °C

LINEAR SPEED [mm/s]	DYNAMIC LOAD [N]	RATIO	MOTOR: POWER [kW] — N° of POLES SPEED [rpm]	SELF-LOCKING COEFFICIENT
<b>CLA 30</b>				
46	2350 <sup>1)</sup>	RV1	0.25 kW 2-pole 2800	0.25
23	4800 <sup>1)</sup>	RN2	0.25 kW 2-pole 2800	0.28
15	6300 <sup>1)</sup>	RL2	0.25 kW 2-pole 2800	0.22
11	8000 <sup>1)</sup>	RXL2	0.25 kW 2-pole 2800	0.18
7.5	9200 <sup>1)</sup>	RL1	0.25 kW 2-pole 2800	0.16
5.5	10000 <sup>2)</sup>	RXL1	0.25 kW 2-pole 2800	0.13
4	10000 <sup>2)</sup>	RL1	0.18 kW 4-pole 1400	0.16
2.7	10000 <sup>2)</sup>	RXL1	0.18 kW 4-pole 1400	0.13
<b>CLA 40</b>				
46	5400 <sup>1)</sup>	RV1	0.55 kW 2-pole 2800	0.26
23	10000 <sup>1)</sup>	RN2	0.55 kW 2-pole 2800	0.25
18	12000 <sup>2)</sup>	RL2	0.55 kW 2-pole 2800	0.24
11	12000 <sup>2)</sup>	RN1	0.55 kW 2-pole 2800	0.18
8.5	12000 <sup>2)</sup>	RXL2	0.55 kW 2-pole 2800	0.12
5.5	12000 <sup>2)</sup>	RN1	0.37 kW 4-pole 1400	0.18
4.5	12000 <sup>2)</sup>	RL1	0.37 kW 4-pole 1400	0.17
2.1	12000 <sup>2)</sup>	RXL1	0.37 kW 4-pole 1400	0.08

## Linear actuators CLB Series

### BALL SCREW LINEAR ACTUATORS CLB Series with AC 3-PHASE MOTOR PERFORMANCE with: Duty Cycle $F_i = 100\%$ at ambient temperature $25\text{ }^\circ\text{C}$

LINEAR SPEED [mm/s]	DYNAMIC LOAD [N]	RATIO	MOTOR: POWER [kW] — N° of POLES SPEED [rpm]	SELF-LOCKING COEFFICIENT
<b>CLB 30</b>				
60	3300 <sup>1)</sup>	RV1	0.25 kW 2-pole 2800	0.56
30	4350 <sup>2)</sup>	RV1	0.18 kW 4-pole 1400	0.56
15	5500 <sup>2)</sup>	RN1	0.25 kW 2-pole 2800	0.43
10	6300 <sup>2)</sup>	RL1	0.25 kW 2-pole 2800	0.34
7	7000 <sup>2)</sup>	RN1	0.18 kW 4-pole 1400	0.43
5	7900 <sup>2)</sup>	RL1	0.18 kW 4-pole 1400	0.34
3.5	9000 <sup>2) 3)</sup>	RXL1	0.18 kW 4-pole 1400	0.30
<b>CLB 40</b>				
56	5400 <sup>2)</sup>	RV1	0.55 kW 2-pole 2800	0.56
28	6800 <sup>2)</sup>	RV1	0.37 kW 4-pole 1400	0.56
14	8600 <sup>2)</sup>	RN1	0.55 kW 2-pole 2800	0.38
11	9250 <sup>2)</sup>	RL1	0.55 kW 2-pole 2800	0.36
7	10800 <sup>2)</sup>	RN1	0.37 kW 4-pole 1400	0.38
5.5	11600 <sup>2)</sup>	RL1	0.37 kW 4-pole 1400	0.36
2.5	12000 <sup>3)</sup>	RXL1	0.37 kW 4-pole 1400	0.20
<b>CLB 50</b>				
47	11800 <sup>1)</sup>	RV1	0.75 kW 4-pole 1400	0.56
23	20500 <sup>2)</sup>	RN1	1.1 kW 2-pole 2800	0.38
19	22000 <sup>2)</sup>	RL1	1.1 kW 2-pole 2800	0.36
12	25000 <sup>3)</sup>	RN1	0.75 kW 4-pole 1400	0.38
9.3	25000 <sup>3)</sup>	RL1	0.37 kW 4-pole 1400	0.36
4.2	25000 <sup>3)</sup>	RXL1	0.37 kW 4-pole 1400	0.20

1) value limited by electric motor power; ball screw lifetime  $L_{10h} > 1000$  hours (see diagrams on pages 34 ... 35)

The total dynamic efficiency ( $\eta$ ) of CLB Series actuators, used to determine the DYNAMIC LOAD is calculated as follows:

$$\eta = \eta_1 \times \eta_2 \times \eta_3$$

where:

$\eta_1$  – wormgear dynamic efficiency, calculated according to BS 721 : Part 2 : 1983

$\eta_2 = 0.9$  – ball screw - nut efficiency

$\eta_3 = 0.9$  – bearings and sealing elements "efficiency"

2) value related to the ball screw lifetime  $L_{10h} = 1000$  h, with constant load, without load vibrations nor shocks; for different lifetime refer to diagrams on pages 34 ... 35

3) limit value of linear actuator dynamic load capacity (see page 105)

Notes regarding the tables at page 106 (linear actuators CLA Series):

1) value limited by electric motor power

The total dynamic efficiency ( $\eta$ ) of CLA Series actuators, used to determine the DYNAMIC LOAD is calculated as follows:

$$\eta = \eta_1 \times \eta_2 \times \eta_3$$

where:

$\eta_1$  – wormgear dynamic efficiency, calculated according to BS 721 : Part 2 : 1983

$\eta_2$  – acme screw-bronze nut dynamic efficiency, calculated with reference to the speed

$\eta_3 = 0.9$  – bearings and sealing elements "efficiency"

2) limit value of linear actuator dynamic load capacity (see page 104)

# Linear actuators CLA Series

## 3.4 OVERALL DIMENSIONS

ACME SCREW LINEAR ACTUATORS CLA Series, size 30 – 40  
AC 3-phase or 1-phase MOTOR

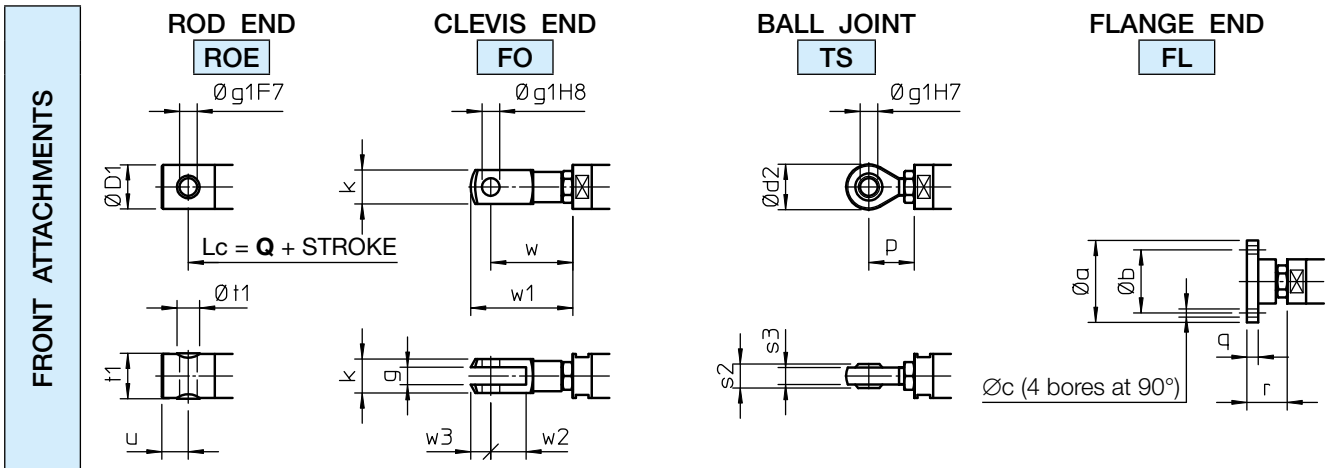
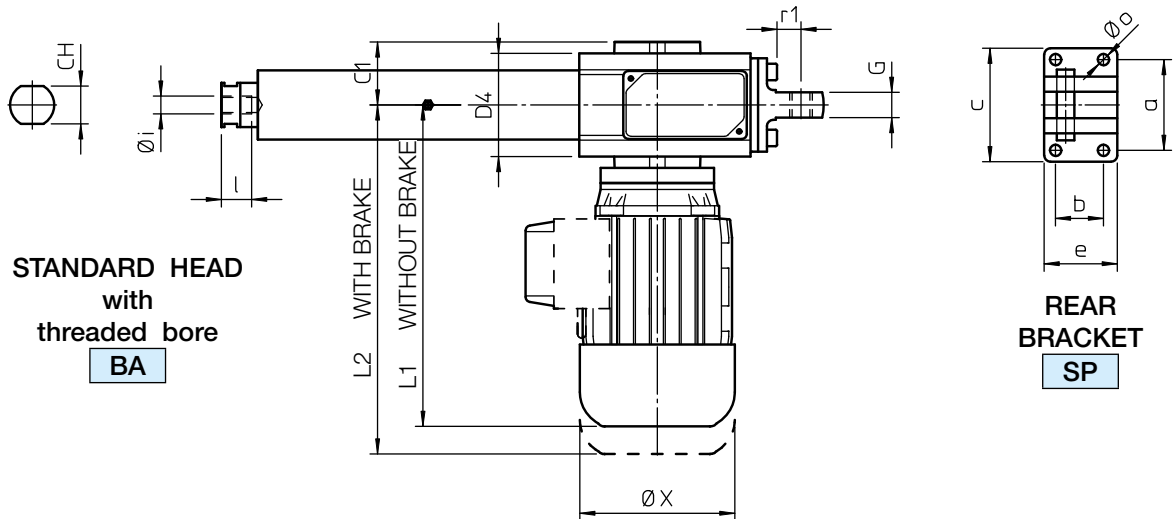
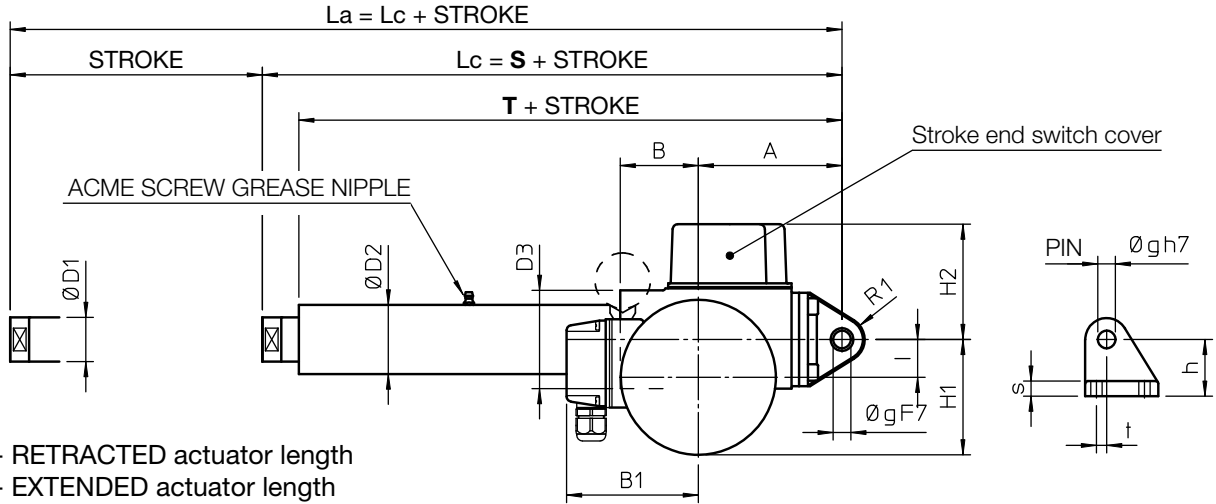

## Linear actuators CLA Series

### 3.4 OVERALL DIMENSIONS

#### ACME SCREW LINEAR ACTUATORS CLA Series, size 30 – 40 AC 3-phase or 1-phase MOTOR

	STROKE CODE	C...	S	T	Q
CLA 30	STROKE [mm] = STROKE CODE	...	260	231	266
CLA 40			304	266	316

ACTUATOR with FC in STANDARD execution	MAX. stroke [mm]
CLA 30 R_1	500
CLA 30 R_2	800
CLA 40 R_1	600
CLA 40 R_2	800

NOTE: Greater stroke lengths available on request.

For stroke lengths longer than 800 mm it is necessary to increase the guided length between push rod and outer tube to avoid axial backlash. Dimensions **S**, **T** and **Q** shall be considered increased by 200 mm for stroke lengths up to 1500 mm.

	A	B	B1	C1	CH	∅ D1	∅ D2	D3	D4	G	H1	H2	I	L1	L2
CLA 30	114	62	115	54	30	35	55	78	82	20	92	92	30	255	291
CLA 40	128.5	78	124	61	36	40	60	92	103	24	111	99	40	284	373

	R1	∅ X	a	b	c	e	∅ g	h	∅ i	l	∅ o	r1	s	t
CLA 30	18	123	72	38	90	58	14	45	M14x2	24	9	20	12	8
CLA 40	28	150	85	55	110	81	20	58	M20x1.5	27	11	32	15	15

#### FRONT ATTACHMENT Dimensions

	∅ a	∅ b	∅ c	∅ D1	∅ d2	g	∅ g1	k	p	p1
CLA 30	65	50	6.5	35	36	14	14	27	36	54
CLA 40	80	60	8.5	40	50	20	20	40	53	78

	q	r	s2	s3	t1	∅ t1	u	w	w1	w2	w3
CLA 30	9	32	19	14	36	18	21	65	81	28	16
CLA 40	10	42	25	18	42	25	27	90	115	40	25



# Linear actuators CLA Series

## 3.4 OVERALL DIMENSIONS

### ACME SCREW LINEAR ACTUATOR CLA 50 AC 3-phase MOTOR

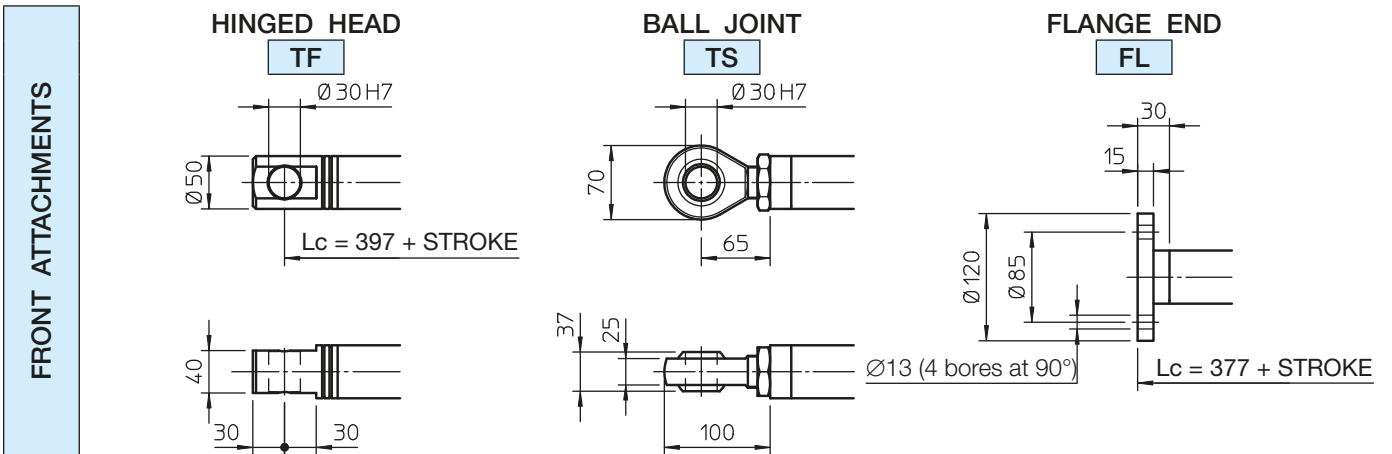
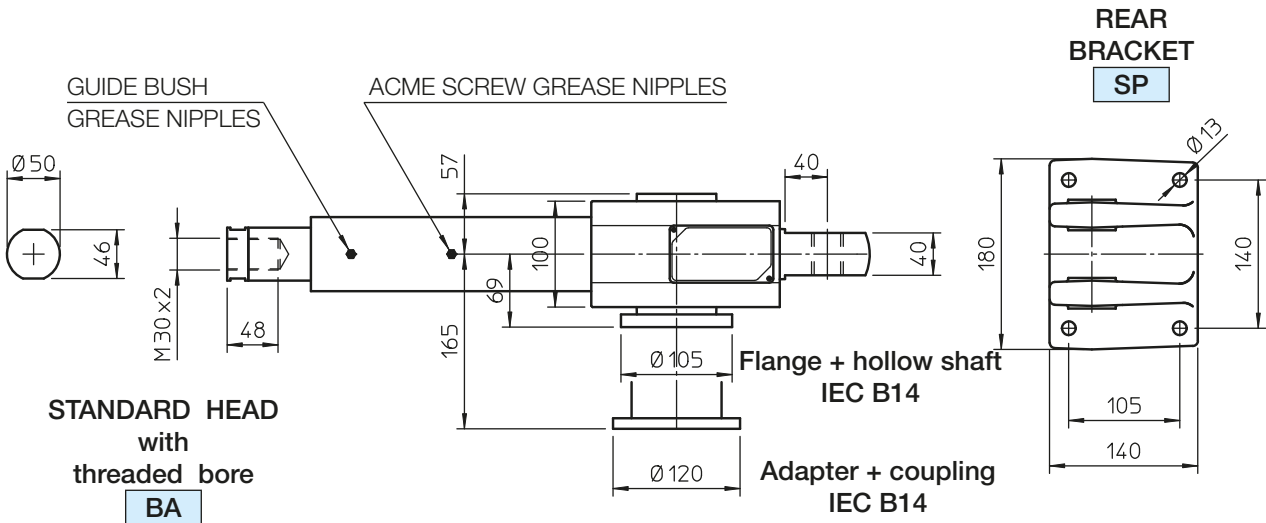
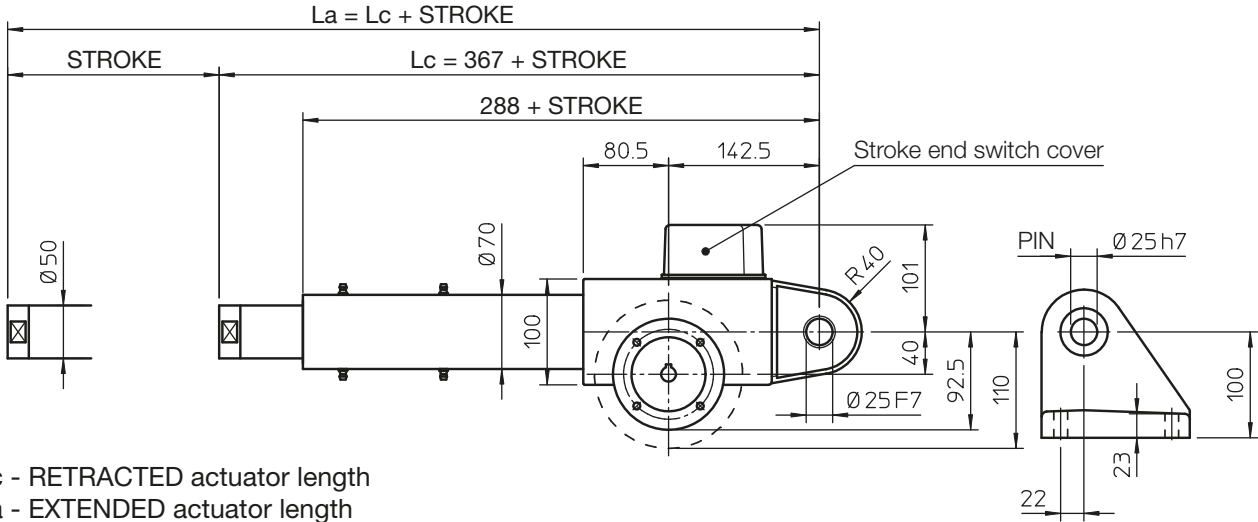

NOTE: For stroke lengths longer than 800 mm it is necessary to increase the guided length between push rod and outer tube to avoid axial backlash. The tube length and the dimensions  $L_c$  and  $L_a$  shall be considered increased by 200 mm for stroke lengths up to max. 1500 mm.

# Linear actuators CLB Series

## 3.4 OVERALL DIMENSIONS

### BALL SCREW LINEAR ACTUATOR CLB 50 AC 3-phase MOTOR

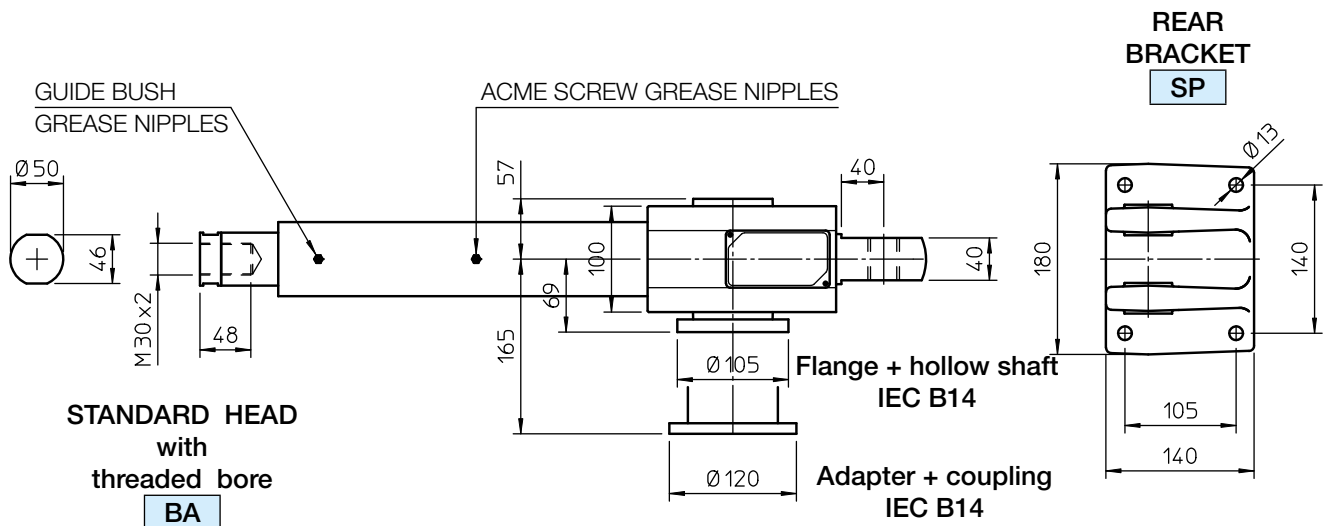
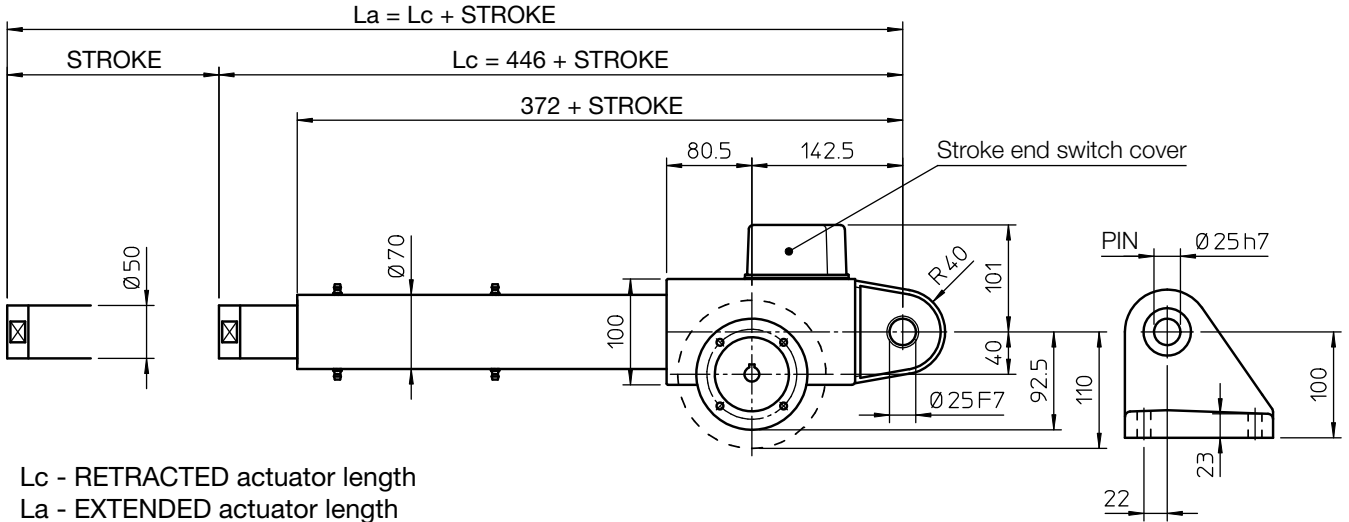

FRONT ATTACHMENTS

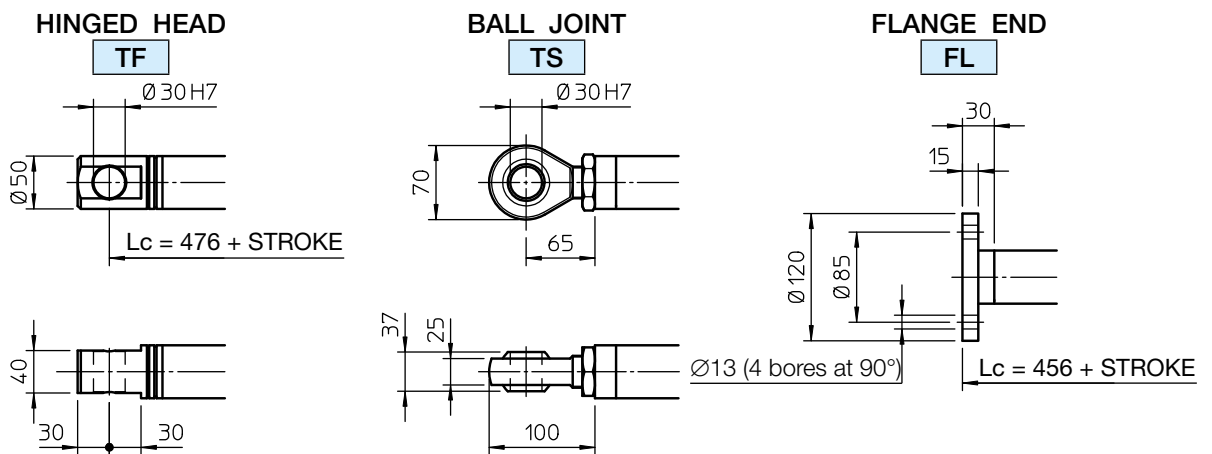

NOTE: For stroke lengths longer than 800 mm it is necessary to increase the guided length between push rod and outer tube to avoid axial backlash. The tube length and the dimensions **Lc** and **La** shall be considered increased by 200 mm for stroke lengths up to max. 1500 mm.

# Linear actuators CLB Series

## 3.4 OVERALL DIMENSIONS

### BALL SCREW LINEAR ACTUATORS CLB Series, size 30 – 40 AC 3-phase MOTOR

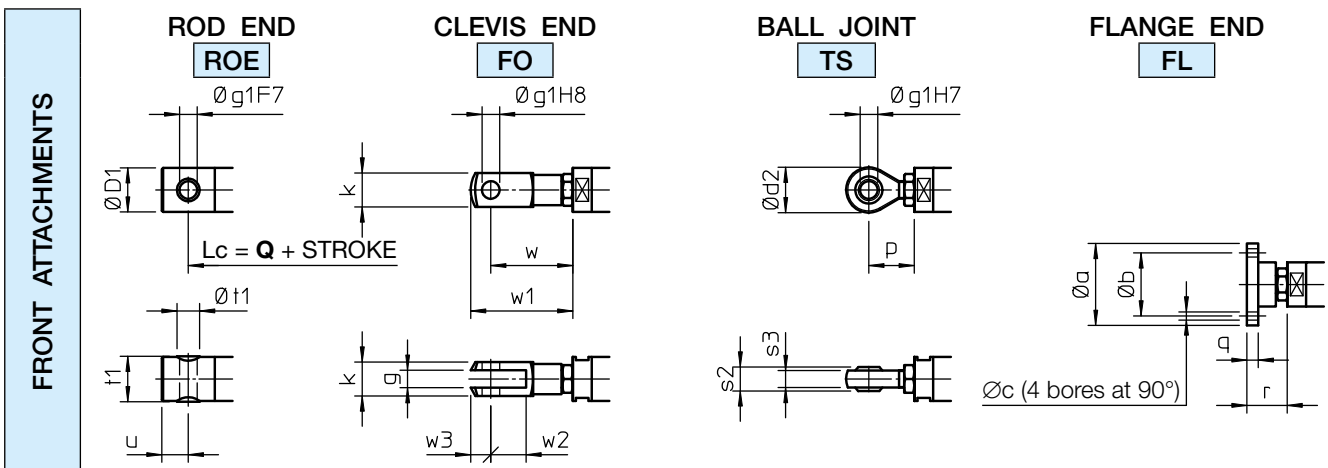
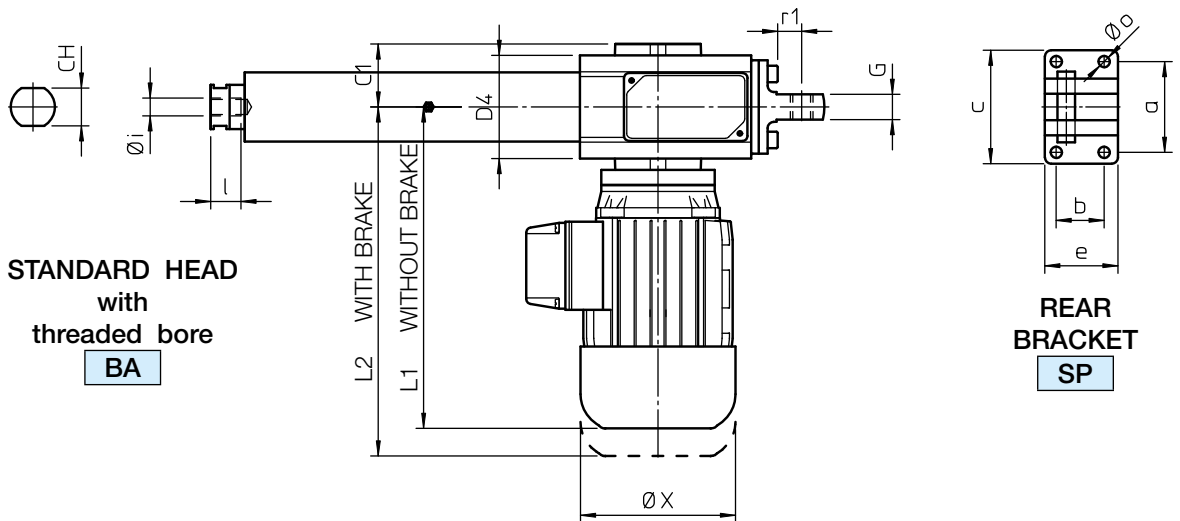
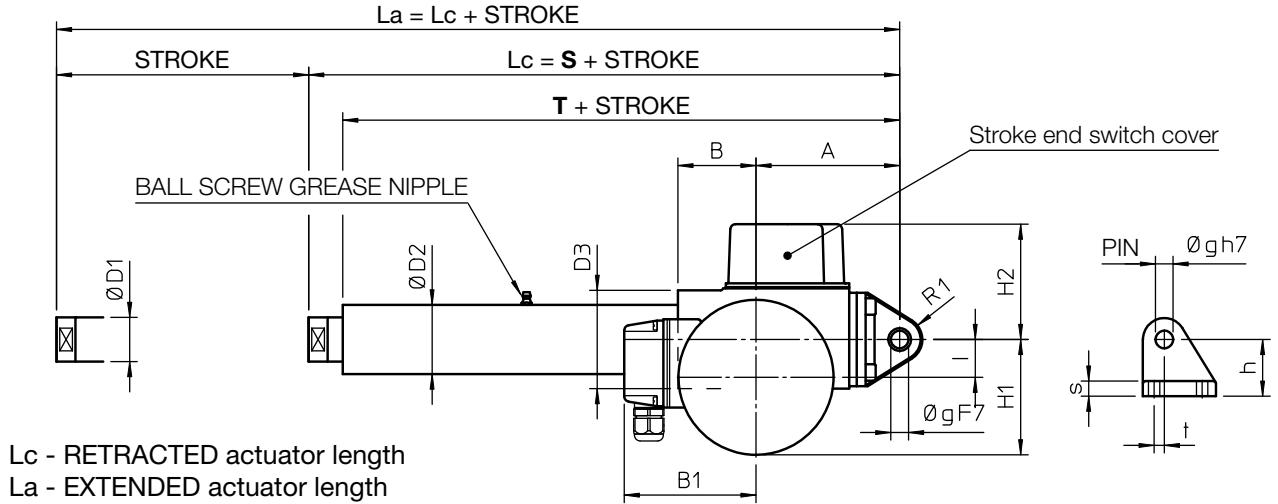

## Linear actuators CLB Series

### 3.4 OVERALL DIMENSIONS

#### BALL SCREW LINEAR ACTUATORS CLB Series, size 30 – 40 AC 3-phase MOTOR

	STROKE CODE	C...	S	T	Q
CLB 30	STROKE [mm] = STROKE CODE	...	269	242	275
CLB 40			313	278	325

ACTUATOR with FC in STANDARD execution	MAX. stroke [mm]
CLB 30	600
CLB 40	800

NOTE: Greater stroke lengths available on request.

For stroke lengths longer than 800 mm it is necessary to increase the guided length between push rod and outer tube to avoid axial backlash. Dimensions **S**, **T** and **Q** shall be considered increased by 200 mm for stroke lengths up to 1500 mm.

	A	B	B1	C1	CH	∅ D1	∅ D2	D3	D4	G	H1	H2	I	L1	L2
CLB 30	114	62	115	54	30	35	55	78	82	20	92	92	30	255	291
CLB 40	128.5	78	124	61	36	40	60	92	103	24	111	99	40	284	373

	R1	∅ X	a	b	c	e	∅ g	h	∅ i	l	∅ o	r1	s	t
CLB 30	18	123	72	38	90	58	14	45	M14x2	24	9	20	12	8
CLB 40	28	150	85	55	110	81	20	58	M20x1.5	27	11	32	15	15

#### FRONT ATTACHMENT Dimensions

	∅ a	∅ b	∅ c	∅ D1	∅ d2	g	∅ g1	k	p	p1
CLB 30	65	50	6.5	35	36	14	14	27	36	54
CLB 40	80	60	8.5	40	50	20	20	40	53	78

	q	r	s2	s3	t1	∅ t1	u	w	w1	w2	w3
CLB 30	9	32	19	14	36	18	21	65	81	28	16
CLB 40	10	42	25	18	42	25	27	90	115	40	25

# Linear actuators CLA Series and CLB Series

## 3.5 OPTIONS AND ACCESSORIES

### MOTOR MOUNTING SIDE – MAIN INPUT SIDE

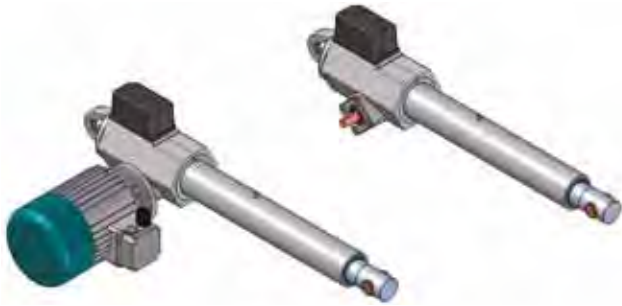

ON REQUEST: LEFT side  
Code: LH

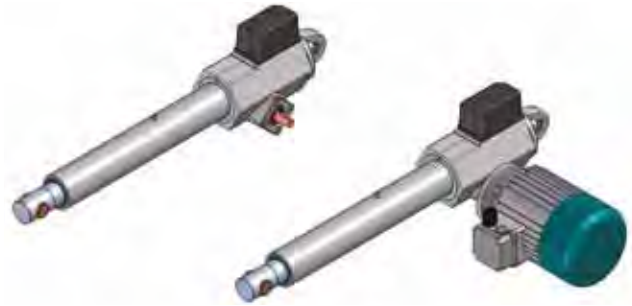

STANDARD: RIGHT side  
Code: RH

### ELECTRIC MOTOR TERMINAL BOX POSITION

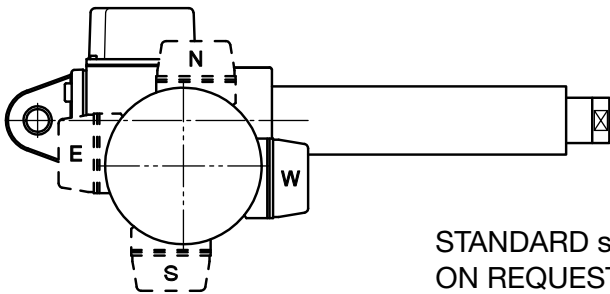

STANDARD side: W  
ON REQUEST side: E ; N ; S

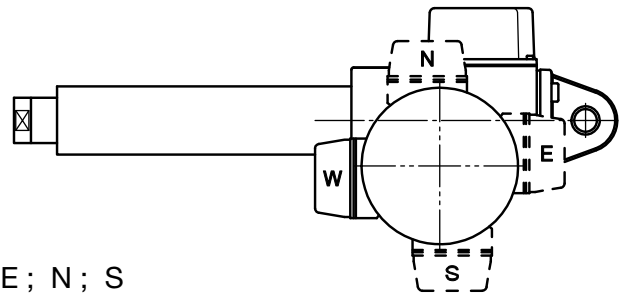

### POSITION OF FRONT AND REAR ACTUATOR ATTACHMENT

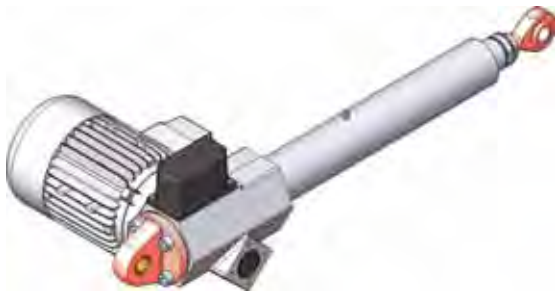

STANDARD

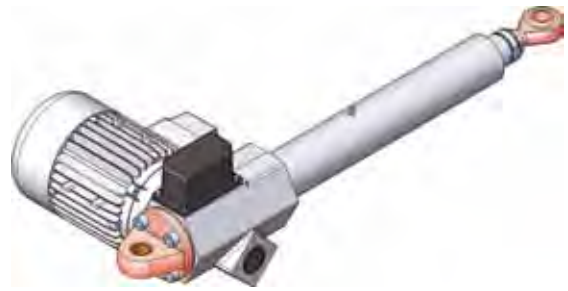

ON REQUEST: turned at 90°  
Code: RPT 90°  
NOTE: NOT available for size 50

### INTERMEDIATE FLANGE Code FI

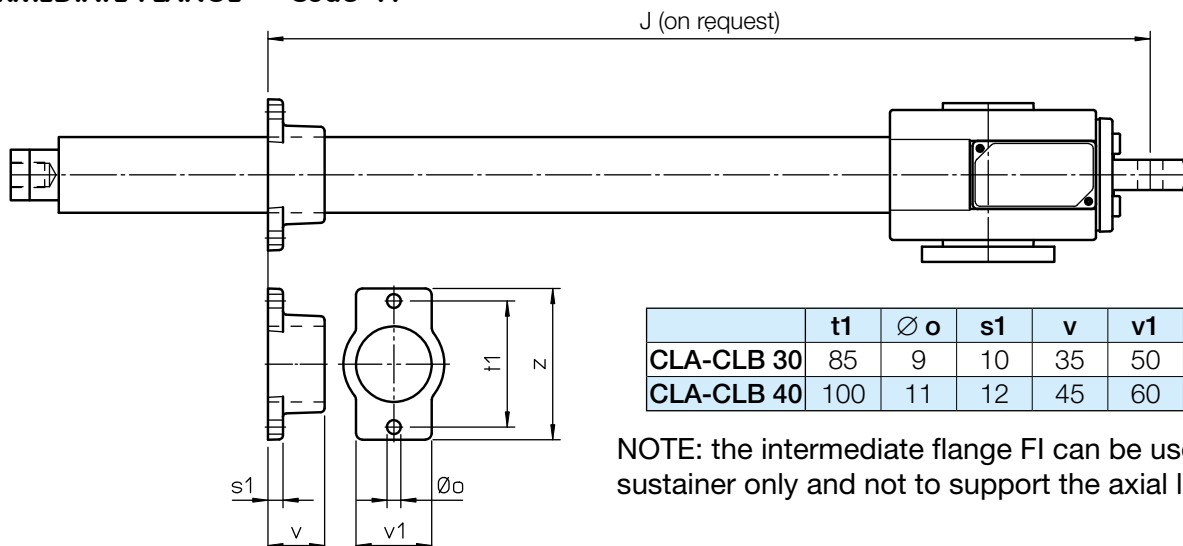

	t1	Ø o	s1	v	v1	z
CLA-CLB 30	85	9	10	35	50	100
CLA-CLB 40	100	11	12	45	60	120

NOTE: the intermediate flange FI can be used as sustainer only and not to support the axial load!

# Linear actuators CLA Series and CLB Series

## 3.5 OPTIONS

### ACTUATOR INPUT – size 30 - 40 - 50

#### Single input shaft Code: Vers.1

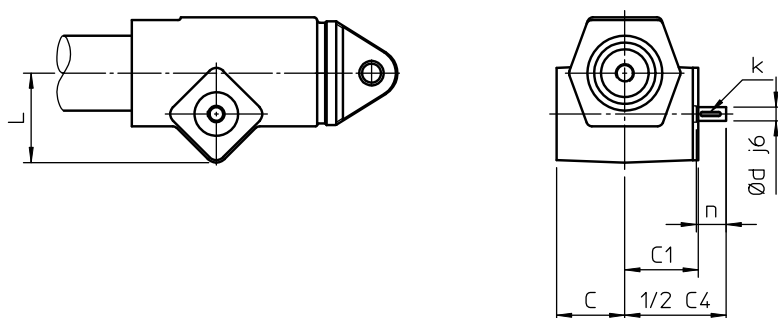

#### Double input shaft Code: Vers.2

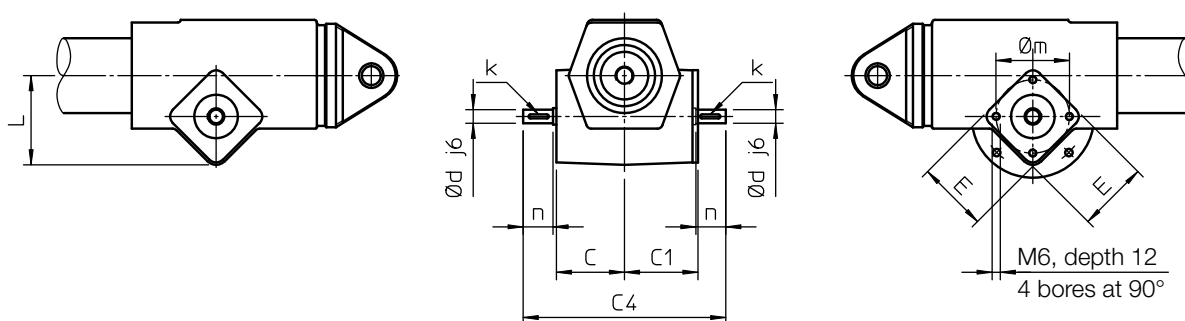

#### Attachment for IEC \_ B14 electric motor (flange and hollow shaft) Code: Vers.3

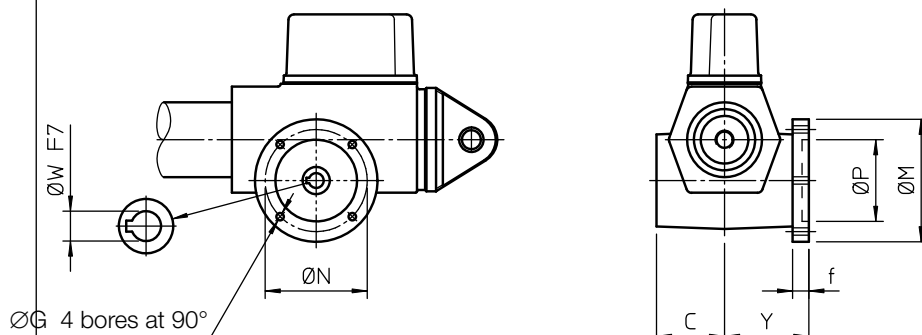

#### Attachment for IEC \_ B14 electric motor (flange and hollow shaft) and second shaft Code: Vers.4

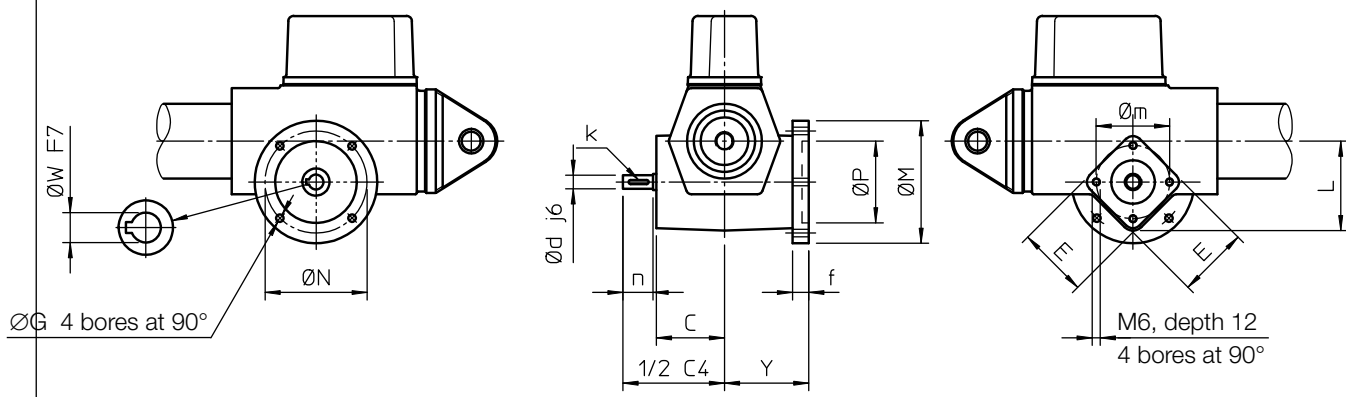

	C	C1	C4	E	L	k	Y	Ø d	Ø m	n	IEC motor	Ø G	Ø M	Ø N	Ø P	Ø W	f
CLA-CLB 30	50	54	149	52	66	3x3x15	62	10	54	22	63 B14	5.5	90	75	60	11	12
CLA-CLB 40	57	61	179	53	80	5x5x20	69	14	54	30	71 B14	6.5	105	85	70	14	12
CLA-CLB 50	57	61	179	53	80	5x5x20	69	14	54	30	71 B14	6.5	105	85	70	14	12

## Linear actuators CLA Series and CLB Series

### 3.5 OPTIONS

#### ACTUATOR INPUT – size 50

**CLA-CLB 50: attachment for IEC \_ B14 electric motor (adapter and coupling)**

Code: **Vers.5**

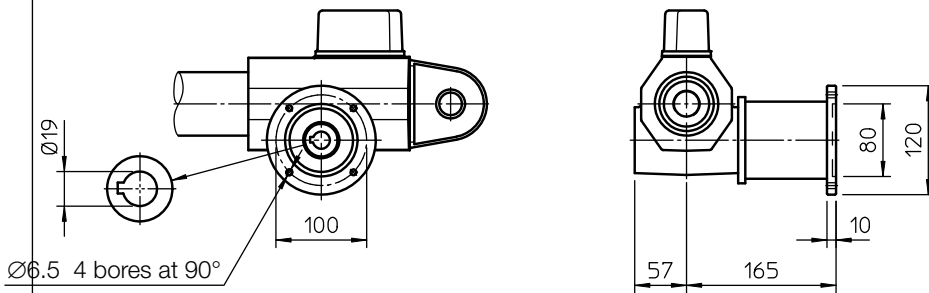

**CLA-CLB 50: attachment for IEC \_ B14 electric motor (adapter and coupling) and second shaft**

Code: **Vers.6**

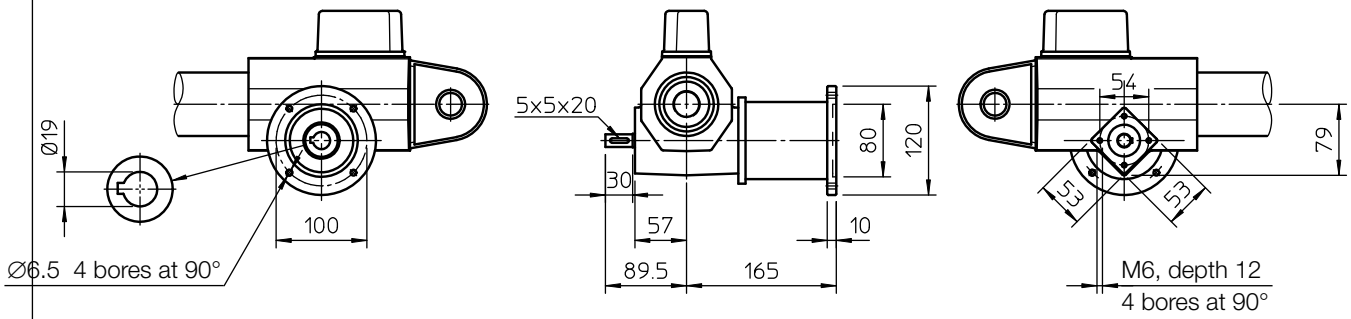

# Linear actuators CLA Series and CLB Series

## 3.5 ACCESSORIES

### ELECTRIC STROKE END SWITCHES Code FC

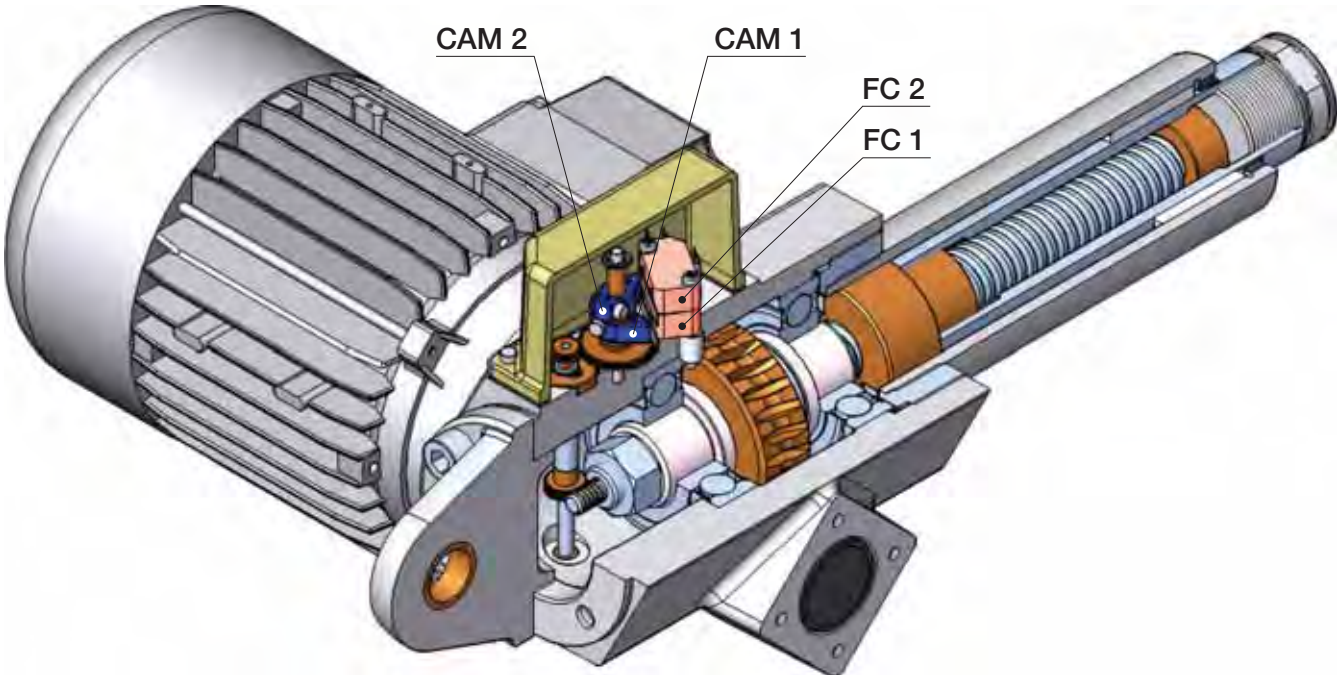

The ELECTRIC STROKE END SWITCHES allow to limit the actuator stroke avoiding to exceed the extreme positions (Lc or La) and reach the mechanical stops and in this way preventing possible damage.

The ELECTRIC STROKE END SWITCHES consists of two normally closed miniature electric switches that are fixed on the actuator housing and operated by cams.

The cams are driven by the acme or ball screw through a two-stage gear transmission. The first stage consists of a worm gear with constant ratio. The second stage consists of a cylindrical straight-tooth gear with ratio that depends on the maximum actuator stroke.

To set up the actual actuator working stroke, the rod shall be positioned in the required position (EXTENDED ACTUATOR or RETRACTED ACTUATOR) and set the position of the relevant cam around the support tube, turning and fixing it in the right position. **CAM 1** operates the switch **FC 1**, which corresponds to the RETRACTED ACTUATOR (Lc) stopping position, while **CAM 2** operates the switch **FC 2**, which corresponds to the EXTENDED ACTUATOR (La) stopping position.

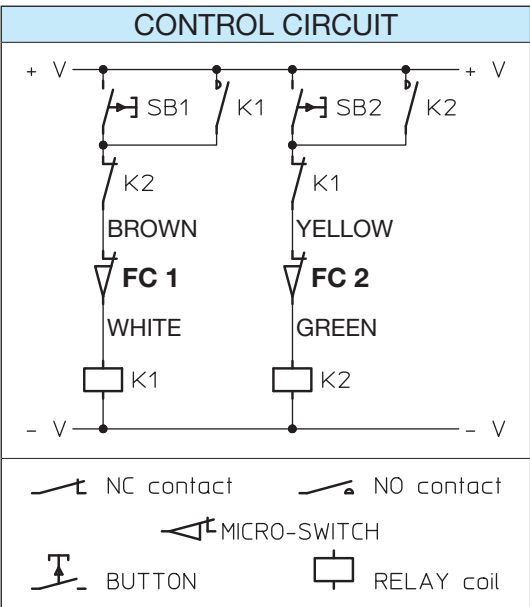

The entire assembly – switches, cams and cam driving transmission - is inside a sealed box.

The ELECTRIC STROKE END SWITCHES must be connected to the electric control circuit as shown in the WIRING DIAGRAM on the left to guarantee motor switch off and to prevent damage to the actuator and to the application equipment.

The ELECTRIC STROKE END SWITCHES are supplied already wired with a multicore cables 2 × 0.75 mm<sup>2</sup>, standard length 1.5 m or longer cable on request. The wire colours are indicated in the diagram.

RATED CONTACT VALUES			
Voltage	250 V AC	125 V AC	125 V DC
Current (resistive load)	16 A	16 A	0.6 A
Current (inductive load)	10 A	10 A	0.6 A



# Linear actuators CLA Series and CLB Series

## 3.5 ACCESSORIES

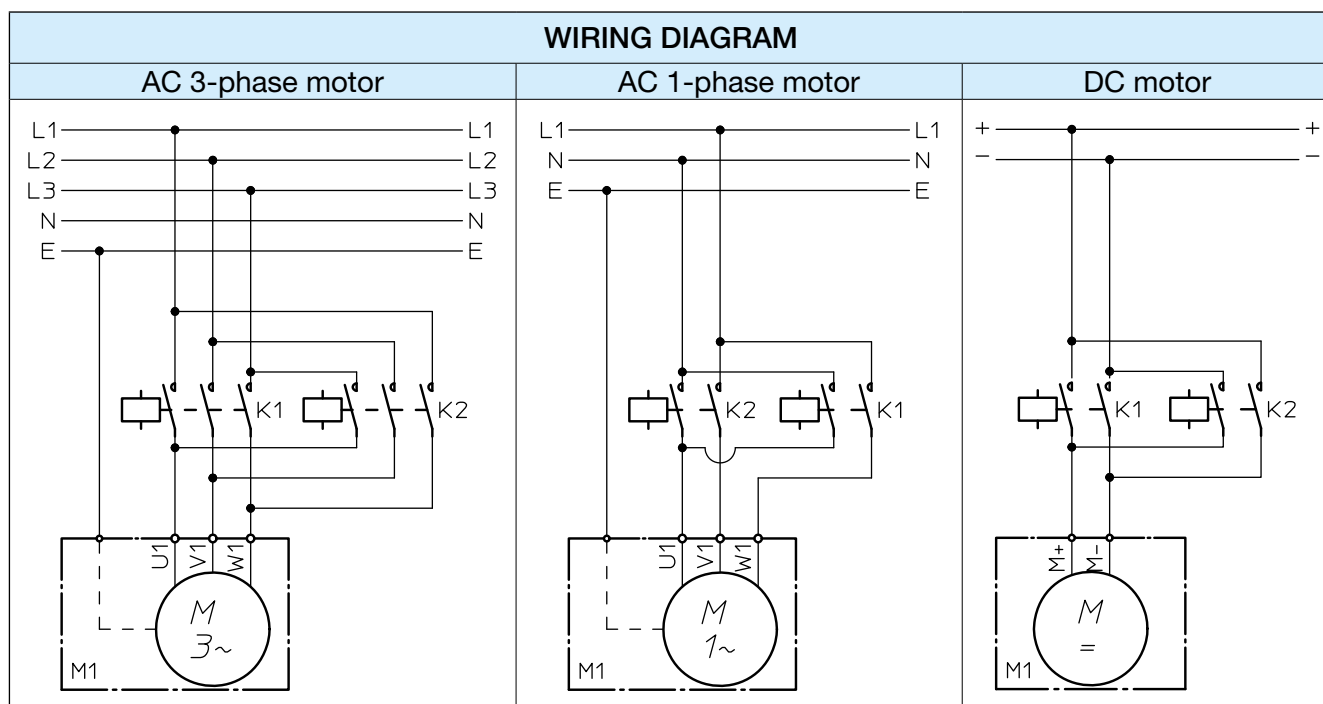

### SWITCH FOR INTERMEDIATE POSITION Code FC 3

In case an electric signal is required to identify any intermediate position of the push rod (between Lc and La), in addition to the two switches **FC 1** and **FC 2** an extra switch **FC 3**, mounted above the first two and operated by the relevant **CAM 3**, can be supplied.

**WARNING!** The push rod position determined by the switch **FC 3** while the push rod is extending is different from the push rod position determined by the switch **FC 3** while the push rod is retracting. It is therefore necessary to verify the difference between the two positions, by direct check or asking **SERVOMECH**, to evaluate the compatibility with the application requirements.

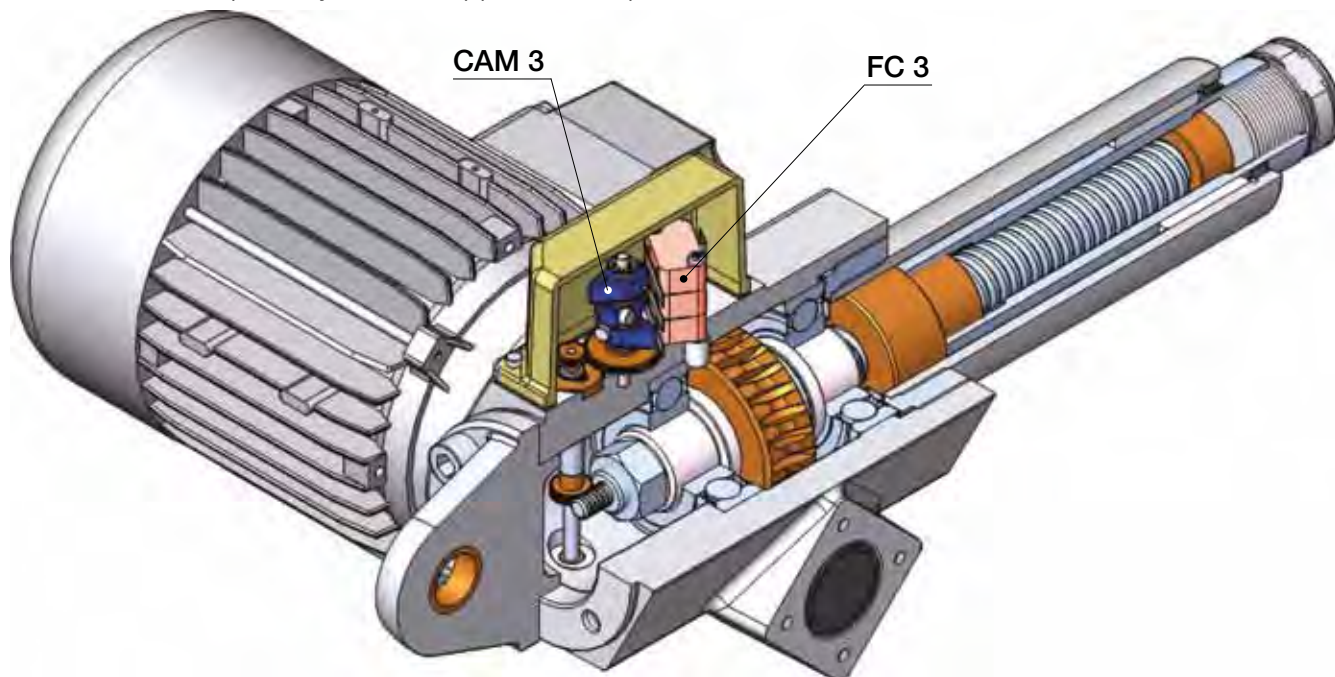

The switch **FC 3** is supplied with normally CLOSED contact already wired with a multicore cable  $2 \times 0.75 \text{ mm}^2$ , standard length 1.5 m or longer cable on request. The wire colours are BLUE and BROWN.

# Linear actuators CLA Series and CLB Series

## 3.5 ACCESSORIES

### ROTARY POTENTIOMETER Code POR 5k

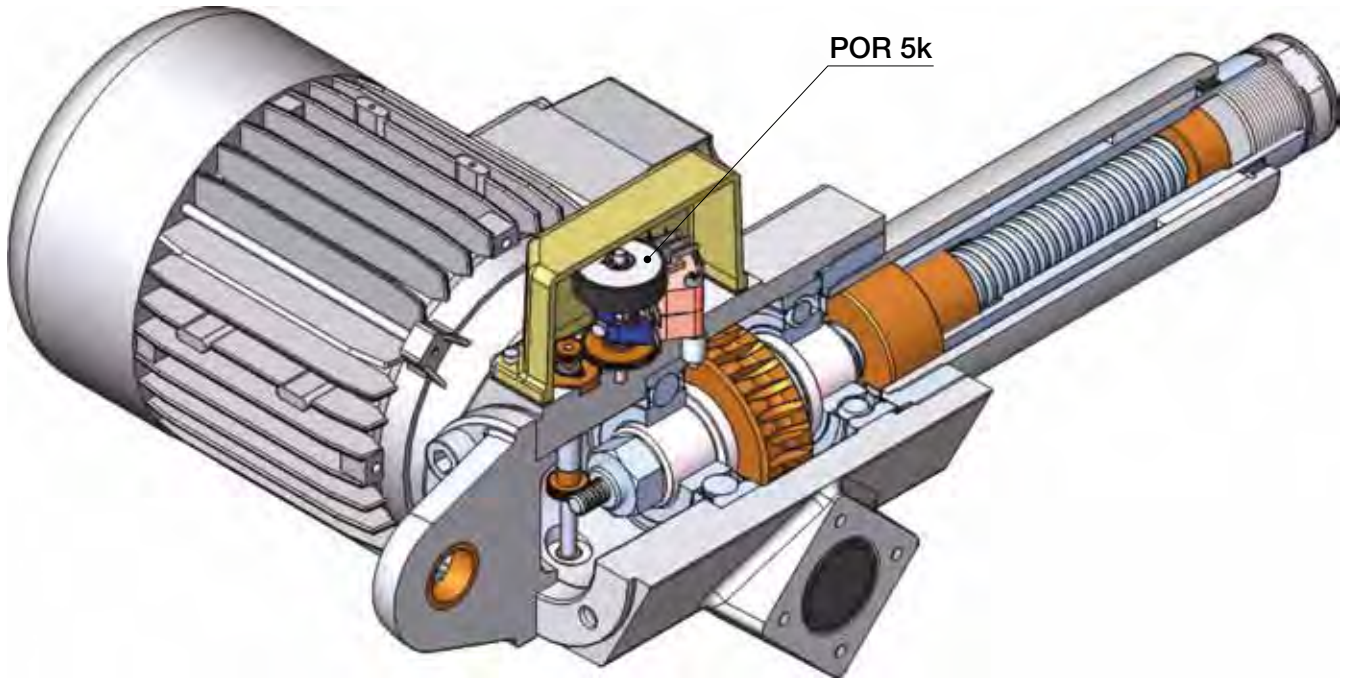

The ROTARY POTENTIOMETER is an absolute transducer whose output signal is proportional to the distance between the reference position ("ZERO" position) and the current position of the actuator push rod. The ROTARY POTENTIOMETER gives an analog output signal.

The ROTARY POTENTIOMETER is mounted on the same shaft that supports the cams which operate the stroke end switches and therefore it is driven by the same gear transmission. While the part of the potentiometer which contains the electric resistance remains stationary, because it is connected to the actuator housing through a reaction arm, the other part with the cursor inside is driven by the transmission shaft and rotates.

Electric features of the ROTARY POTENTIOMETER **POR 5k**:

- type: single-turn (340°)
- nominal resistance: 5 kΩ
- resistance tolerance: ± 20 %
- linearity: ± 2 %

Recommended wiring connection:

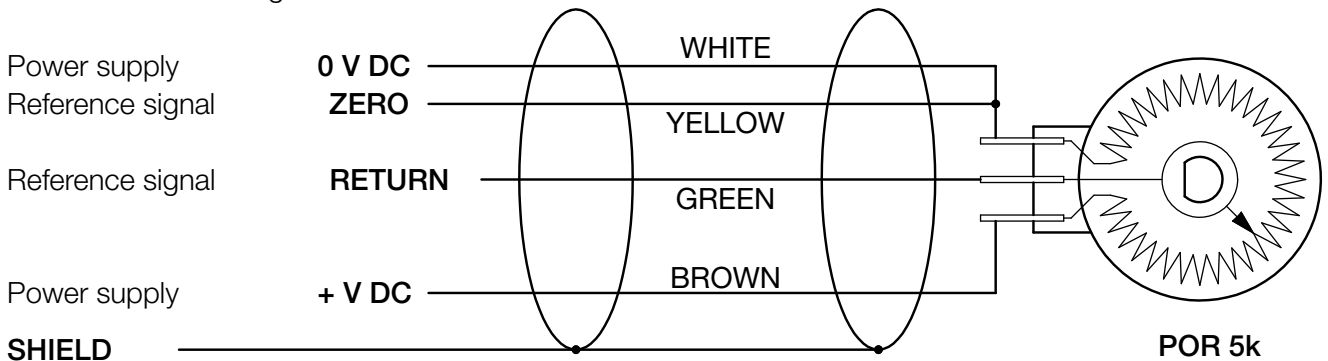

Multicore cable 4 × 0.25 mm<sup>2</sup> + shield, 1.5 m long

# Linear actuators CLA Series and CLB Series

## 3.5 ACCESSORIES

### ANTI-TURN device Code AR

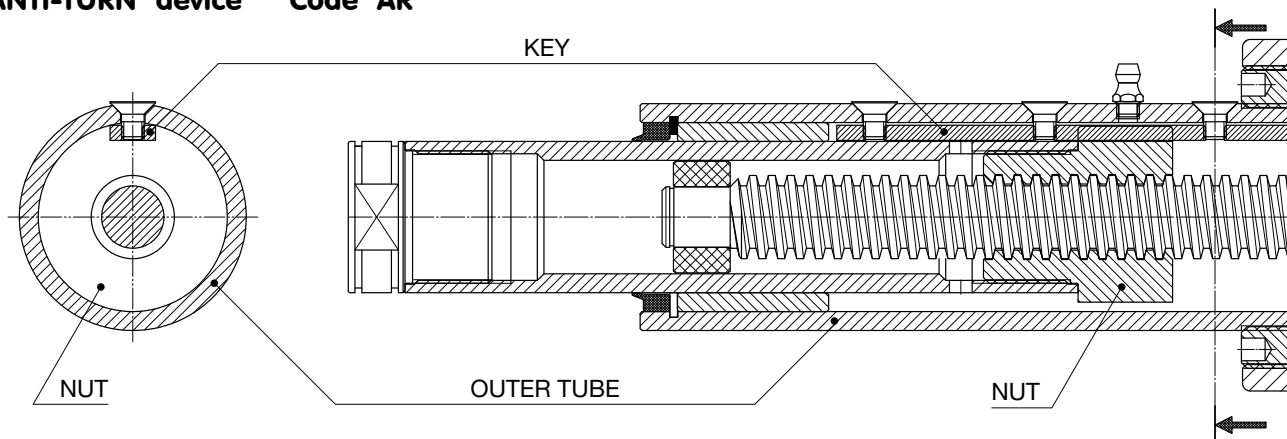

To achieve a linear motion it is necessary to prevent the rotary movement of the nut and of the push rod fixed to it. In many applications it is the external structure itself that, being connected to the push rod, prevents the rotation and allows the linear motion.

In some cases the load applied on the push rod cannot be guided and therefore the rotation cannot be avoided. In such cases it is necessary to use actuators with an internal anti-turn device. The ANTI-TURN device allows the linear motion without any external reaction on the push rod. It can be supplied upon request.

The anti-turn device shown in the above picture consists in a steel key fixed and aligned along the outer tube. The bronze nut, provided with a suitable keyway, slides on this key, making translate the push rod.

The ANTI-TURN DEVICE AR is available for acme screw linear actuators CLA Series only.

### SAFETY CLUTCH Code FS

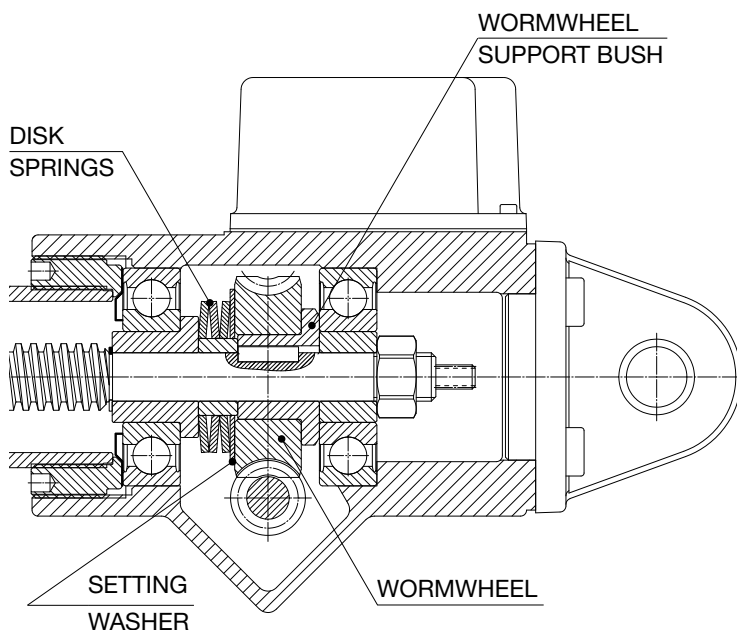

The SAFETY CLUTCH is a device able to protect the actuator and the machinery where it is installed from dynamic overload during the linear travel and from incorrect use which could bring the actuator to the mechanical stop. This device is a torque limiter on the worm wheel. The torque limiter clutch is preloaded during assembly. The preload is fixed and related to the ratio and the performances of each actuator as stated on the PERFORMANCE TABLES in this catalogue.

On request, with a purchasing order, a different preload can be set to achieve different performance.

If an overload is applied on the actuator, the SAFETY CLUTCH starts slipping and the push rod stops while the motor is still running.

When the overload decreases up to the rated load value or less, the SAFETY CLUTCH stops slipping and the push rod starts travelling again. The SAFETY CLUTCH FS is not intended to be used as a load limiter, but only to protect the actuator and the machinery where it is installed. Do not use the SAFETY CLUTCH as a stroke end control device! If it is frequently activated it rapidly wears, the preload is reduced and consequently also the actuator load performance is lower.

3

## Linear actuators CLA Series and CLB Series

### 3.5 ACCESSORIES

#### SAFETY NUT Code MS

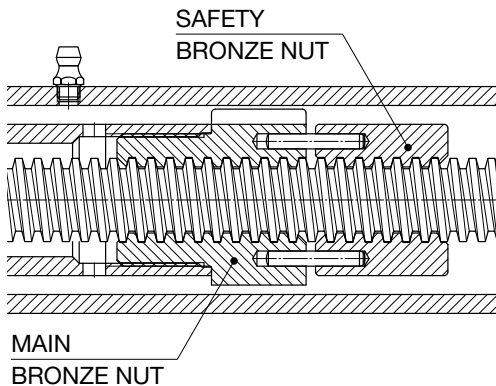

The SAFETY NUT is an auxiliary bronze nut connected by 2 pins to the main bronze nut. The distance between the two nuts in a new actuator is equal to a half of the thread pitch. If the main nut wears up to a half of the thread pitch or crashes, the SAFETY NUT supports the load avoiding its fall.

**The SAFETY NUT is a one-direction device.** Its position with respect to the main nut depends on the load direction. The SAFETY NUT is available for actuators working with push load. For applications with pull load a special design is available (contact SERVOMECH).

The SAFETY NUT MS is available for all acme screw actuators (CLA Series).

#### PROTECTIVE BELLOWS Code B

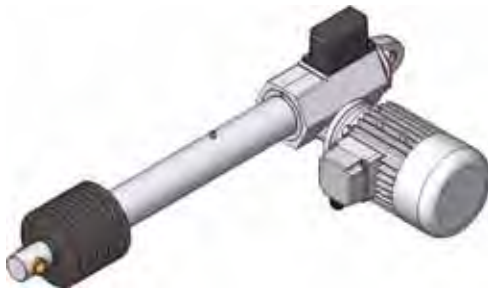

When the actuators are used in severe environment conditions with contaminant agents that can damage the seal scraper between the outer tube and the push rod, BELLOWS protection can be useful.

BelloWS made of special materials for severe environments are available upon request.

### 3.6 SPECIAL DESIGNS

According to specific application requirements, special designs can be carried out on standard actuators.

Some possible options are for example:

- push rod in stainless steel AISI 304
- outer tube in stainless steel AISI 304
- lubricants for high or low ambient temperature
- lubricants suitable for food industry
- seals in VITON or silicone
- wiper seal on push rod with second lip in brass (ice scrapers)

Thanks to the long experience and know-how, SERVOMECH is able to support customers in selecting the right actuator version and accessories suitable for specific environment and installation conditions.

# Linear actuators CLA Series and CLB Series

## 3.7 ORDERING CODE

CLA	40	RL1	C300	FO	—	FC+FC3	Vers. 3	RH
1	2	3	4	5	6	7	8.A	8.B

SP	...							
9								

AC 3-phase motor	0.37 kW	4-pole	230/400 V	50 Hz	IP 55	Ins. F		
10.A								W
								10.B

1	Actuator series CLA or CLB	
2	Actuator size 30, 40, 50	pages 104 ... 105
3	Ratio RV1, RN1, RL1, RXL1 RV2, RN2, RL2, RXL2	pages 104 ... 105
4	Stroke code (C...)	
5	Front attachment BA - standard head with threaded bore ROE - rod end FO - clevis end TS - ball joint FL - flange end TF - hinged head	pages 108 ... 113
6	Position of front and rear actuator attachment STANDARD (without code) or RPT 90°	page 114
7	Stroke end switches, Rotary potentiometer FC - electric stroke end switches FC + FC3 - electric stroke end switches + switch for intermediate position FC + POR 5k - electric stroke end switches + Rotary potentiometer 5 kOhm	page 117 page 118 page 119
8.A	Actuator input Vers.1 - single input shaft Vers.2 - double input shaft Vers.3 - attachment for IEC motor (flange and hollow shaft) Vers.4 - attachment for IEC motor (flange and hollow shaft) + second shaft Vers.5 - attachment for IEC motor (adapter and coupling) Vers.6 - attachment for IEC motor (adapter and coupling) + second shaft	pages 115 ... 116
8.B	Motor mounting side - main input drive side RH (standard) or LH	page 114
9	Accessories SP - rear bracket FI - intermediate support flange AR - anti-turn device FS - safety clutch MS - safety nut for push load B - bellows	pages 108 ... 113 page 114 page 120 page 120 page 121 page 121
10.A	Motor data	pages 200 ... 201
10.B	Motor terminal box position	page 114
11	Other specifications example: push rod in stainless steel AISI 303 example: lubricant for low temperature	
12	Filled in SELECTION DATA sheet	page 123
13	Application layout	



APPLICATION: \_\_\_\_\_

REQUIRED STROKE: \_\_\_\_\_ mm

REQUIRED LINEAR SPEED: \_\_\_\_\_ mm/s    \_\_\_\_\_ mm/min    \_\_\_\_\_ m/min    TIME TO PERFORM 1 STROKE: \_\_\_\_\_ s

**STATIC LOAD:**            PULL: \_\_\_\_\_ N            PUSH: \_\_\_\_\_ N            at STROKE \_\_\_\_\_ mm

**DYNAMIC LOAD:**        PULL: \_\_\_\_\_ N            PUSH: \_\_\_\_\_ N            at STROKE \_\_\_\_\_ mm

ACTUATOR     SUBJECTED TO VIBRATIONS     NOT SUBJECTED TO VIBRATIONS

OPERATING:            \_\_\_\_\_ cycle / hour    \_\_\_\_\_ working hours / day            Notes: \_\_\_\_\_

REQUIRED LIFETIME: \_\_\_\_\_ cycle    \_\_\_\_\_ hours    \_\_\_\_\_ calendar days            Notes: \_\_\_\_\_

ENVIRONMENT:    TEMPERATURE \_\_\_\_\_ °C     DUST    HUMIDITY \_\_\_\_\_ %    AGGRESSIVE AGENT \_\_\_\_\_

Acme screw actuators **CLA Series**             Ball screw actuators **CLB Series**

Size:             30             40             50

Ratio:             RV2     RV1     RN2     RN1     RL2     RL1     RXL2     RXL1

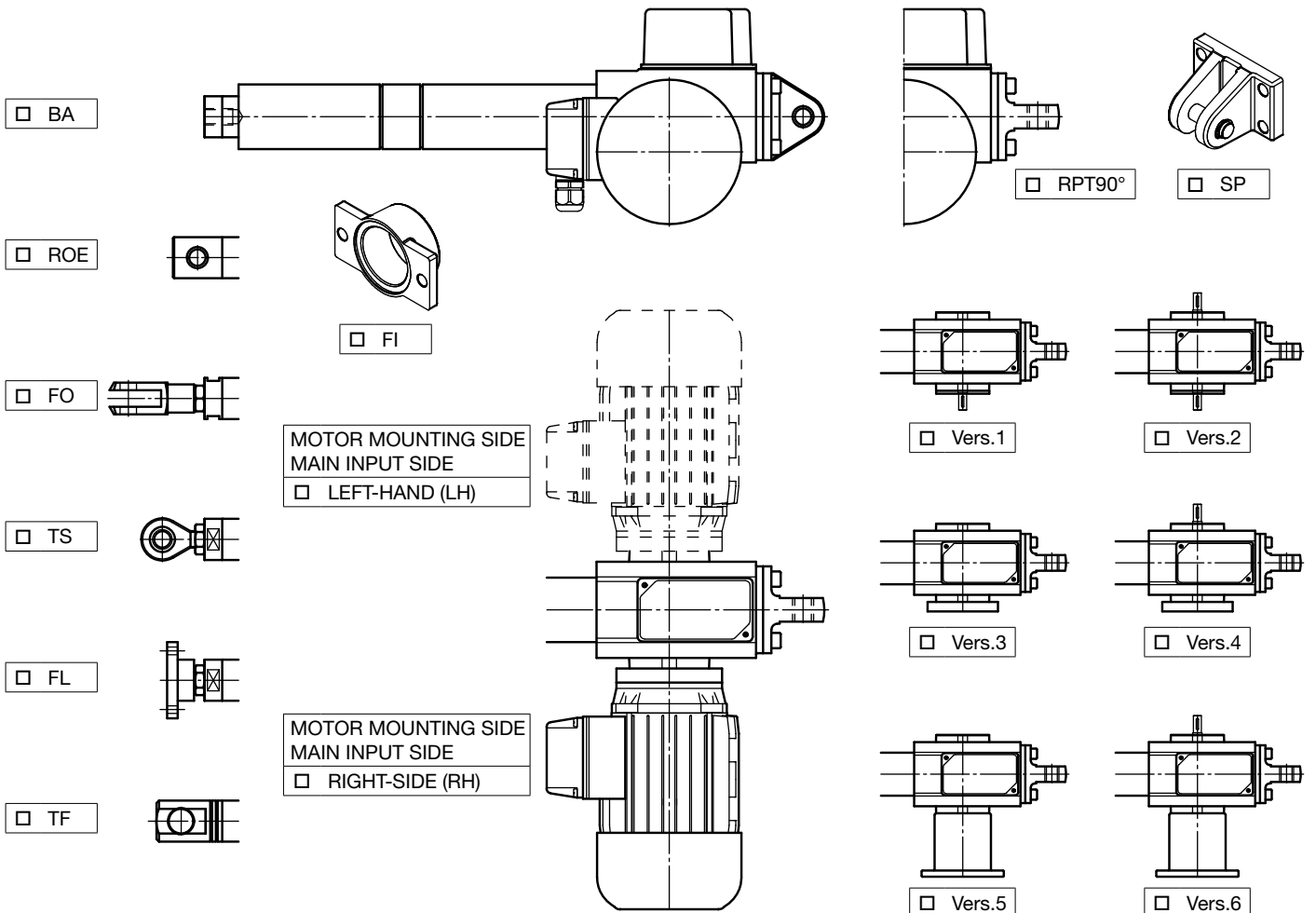

- ELECTRIC MOTOR**     AC 3-phase     AC 1-phase     DC 24 V or 12 V             WITHOUT BRAKE     WITH BRAKE  
 ELECTRIC STROKE END SWITCHES FC     SWITCH FOR INTERMEDIATE POSITION FC3             ROTARY POTENTIOMETER POR5k  
 ANTI-TURN DEVICE AR     SAFETY CLUTCH FS             SAFETY NUT MS  
 BELLOWS             PUSH ROD IN STAINLESS STEEL     OUTER TUBE IN STAINLESS STEEL

OTHER: \_\_\_\_\_

Acme screw actuators **CLA Series**

Ball screw actuators **CLB Series**

PRODUCT: \_\_\_\_\_

Product serial number: \_\_\_\_\_ ; q.ty: \_\_\_\_\_

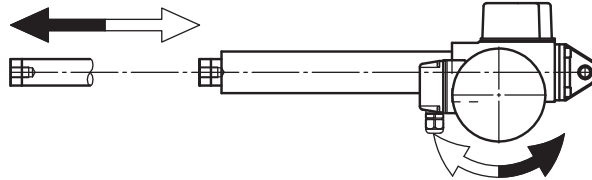

**STANDARD HEAD**

BA

**LEFT-HAND MOUNTING**

**RIGHT-HAND MOUNTING**

**CLEVIS END**

FO

**ELECTRIC MOTOR**

- AC 3-phase
- AC 1-phase
- DC

**BALL JOINT**

TS

- WITHOUT brake
- WITH brake

**FLANGE END**

FL

- internally powered
- separately powered

**ROD END**

ROE

**Servomech. QMS**

**PASSED**

Date: \_\_\_\_\_

Signature: \_\_\_\_\_

**HINGED HEAD**

TF

**LINEAR ACTUATOR LENGTH (ref. to**  BA  ROE  TF  FL)

**WORKING RANGE**

**INTERNAL MECHANICAL STOP LIMIT**

RETRACTED ACTUATOR length:  $L_c =$  \_\_\_\_\_ mm

MIN. actuator length: \_\_\_\_\_ mm

EXTENDED ACTUATOR length:  $L_a =$  \_\_\_\_\_ mm

MAX. actuator length: \_\_\_\_\_ mm

STROKE ( $L_a - L_c$ ):  $C =$  \_\_\_\_\_ mm

## ELECTRIC STROKE END SWITCHES FC □

## SWITCH FOR INTERMEDIATE POSITION FC 3 □

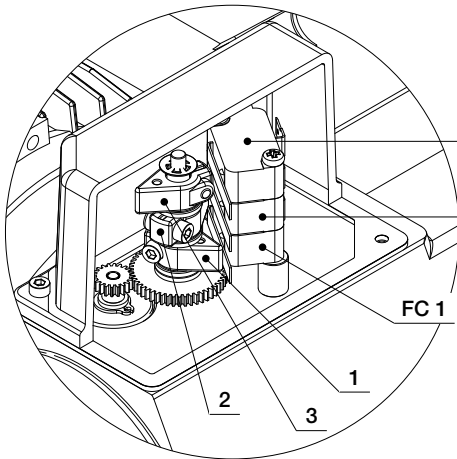

The ELECTRIC STROKE END SWITCHES **FC** has miniature switches FC 1 and FC 2. The switch FC 3 can determine any intermediate position between Lc and La.

- contact: **normally CLOSED**
- voltage: 250 V AC / 125 V AC / 125 V DC
- current: 16 A / 16 A / 0.6 A (resistive load)  
10 A / 10 A / 0.6 A (inductive load)

The RETRACTED ACTUATOR position is set by the adjustable cam 1. The wires that connect the switch FC 1 are WHITE and BROWN.

The EXTENDED ACTUATOR position is set by the adjustable cam 2. The wires that connect the switch FC 2 are GREEN and YELLOW.

The INTERMEDIATE position is set by the adjustable cam 3. The wires that connect the switch FC 3 are BLUE and BROWN.

SINGLE SWITCH WIRING:

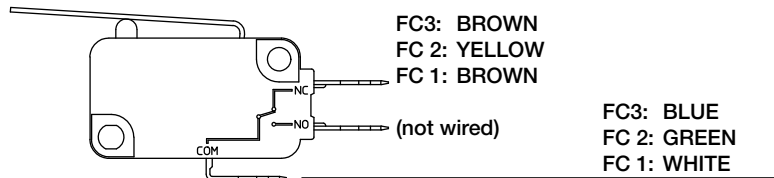

## ROTARY POTENTIOMETER POR 5k □

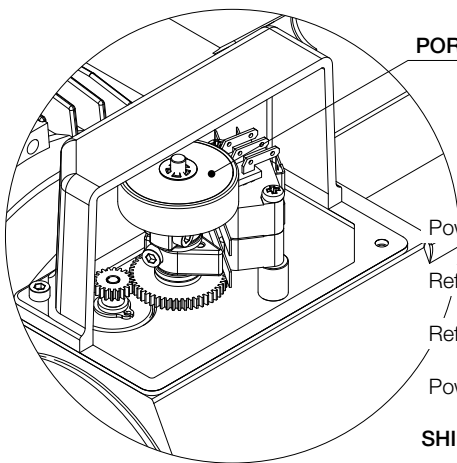

Technical features:

- type: single-turn (340°)
- nominal resistance: 5 kΩ
- resistance tolerance: ± 20 %
- linearity: ± 2 %

RECOMMENDED WIRING CONNECTION:

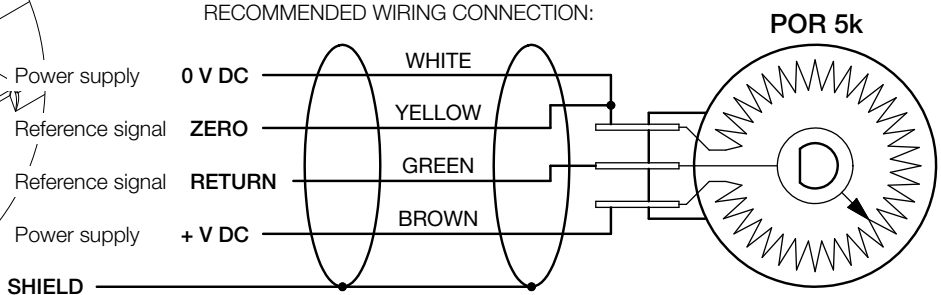

## WARNING!

1. The values **Lc** (RETRACTED ACTUATOR length), **La** (EXTENDED ACTUATOR length) and **C** (STROKE) are the extreme limit values.
2. **BEFORE** using the linear actuator:
  - verify the input shaft rotating direction and the push rod running direction;
  - check the stroke end switches position: they must not exceed the extreme limit positions;
  - make sure that the motor and the limit switches are correctly connected and that the right voltage is used.
3. Linear actuators equipped with brake motor:
  - the brake is **NORMALLY CLOSED** (NEGATIVE action). When the power supply is switched off, the brake is engaged. The brake opens only when power is supplied;
  - if the brake is wired directly to the connecting pins of the terminal box, it does not require any power supply;
  - if the brake is wired separately, make sure that the correct voltage is used;
  - if the brake is equipped with hand release device, make sure that the brake is engaged before starting the linear actuator.
4. **Alignment check:** the load must be in line with the actuator. No off-set or radial loads are allowed.

NOTE: \_\_\_\_\_

WORMGEAR LUBRICANT: \_\_\_\_\_

SCREW – NUT LUBRICANT: \_\_\_\_\_