

SERVOMECH Linear Actuators

7.1 AC 3-phase electric motors

AC asynchronous 3-phase motors, totally enclosed, fan-cooled, with or without brake, made by Italian manufacturers according to IEC standards.

Dynamically balanced rotor, high pressure die-casting housing with fins in aluminium alloy.

Standard: insulation class F, protection class IP 55.

On request: insulation class H and/or higher protection class.

On request: tropicalised winding for ambient with high temperature and humidity.

On request: thermal protection devices.

On request: brake motor.

For more technical information and details, please, refer to manufacturers catalogue.

7.2 AC 1-phase electric motors

AC asynchronous 1-phase motors, totally enclosed, fan-cooled, with or without brake, made by an Italian manufacturers according to IEC standards.

Dynamically balanced rotor, high pressure die-casting housing with fins in aluminium alloy.

Balanced stator windings for clockwise and anti-clockwise running without vibrations. Condenser supplied with motor, with increased capacity for higher starting torque.

Standard: insulation class F, protection class IP 55.

On request: insulation class H and/or higher protection class.

On request: thermal protection devices.

Performances with 50 Hz 230 V power supply:

POWER [kW] N° OF POLES	NOMINAL TORQUE [Nm]	NOMINAL CURRENT [A]	STARTING TORQUE [Nm]	STARTING CURRENT [A]	COND. [μF]	MASS [kg] ¹⁾	MASS [kg] ²⁾
0.09 kW 4-pole	0.64	1.6	1.03	1.9	12.5	3	3.7
0.12 kW 2-pole	0.43	2.6	0.71	3.7	12.5	3	3.7
0.18 kW 4-pole	1.31	1.9	1.37	3.2	16	4.2	5.5
0.25 kW 2-pole	0.84	2.1	0.97	6.3	20	5	5.9
0.37 kW 4-pole	2.64	2.8	2.82	6.1	25	7.2	7.3
0.55 kW 2-pole	1.88	3.9	1.66	11.2	30	7	7.8

1) mass of motor WITHOUT brake

2) mass of motor WITH brake

MOTOR BRAKE: normally closed mechanical brake, activated by a direct current electromagnet 205 V DC, powered by a rectifier in the terminal box (input voltage 230 V AC - output voltage 205 V DC). Brake powered separately: wire terminals into the terminal box.

MOTOR	BRAKING TORQUE [Nm]	CURRENT [A]
0.09 kW 4-pole	1.8	0.05
0.12 kW 2-pole	1.8	0.05
0.18 kW 4-pole	4	0.09
0.25 kW 2-pole	4	0.09
0.37 kW 4-pole	4	0.09
0.55 kW 2-pole	4	0.09

AC 1-phase motors for 60 Hz 110 V are available on request.

7.3 DC electric motors

DC motors with high coercive ferrite permanent magnet field, without fan, made by Italian manufacturers.

Standard: insulation class F, protection class IP 54.

On request: higher protection class.

On request: motor without fan with brake.

SERVOMECH Linear Actuators

Performances at nominal voltage:

MOTOR (nominal power)		100 W	150 W	300 W	500 W	750 W
Nominal voltage	[V]	24	24	24	24	90
Nominal speed	[rpm]	3000	3000	3000	3000	3000
Nominal torque	[Nm]	0.32	0.48	0.96	1.6	2.4
Max. torque	[Nm]	1.6	2.4	4.8	5.7	12
Nominal current	[A]	5.5	8.3	15.6	25	10.6
Max. current	[A]	27.7	41.7	78	89	53
Resistance	[Ω]	0.4	0.29	0.16	0.1	0.71
Inductance	[mH]	0.8	0.73	0.32	0.13	4.6
Mass of motor WITHOUT brake	[kg]	2.9	3.5	5.3	8	9.4

MOTOR BRAKE: normally closed mechanical brake, activated by electromagnet. Brake powered separately, with wire terminals into the terminal box.

MOTOR	BRAKING TORQUE [Nm]	VOLTAGE [V]	CURRENT [A]
100 W	1.7	24 ... 180	0.5
150 W	1.7		0.5
300 W	1.7		0.5
500 W	2		0.7
750 W	8		1

Motor dimensions:

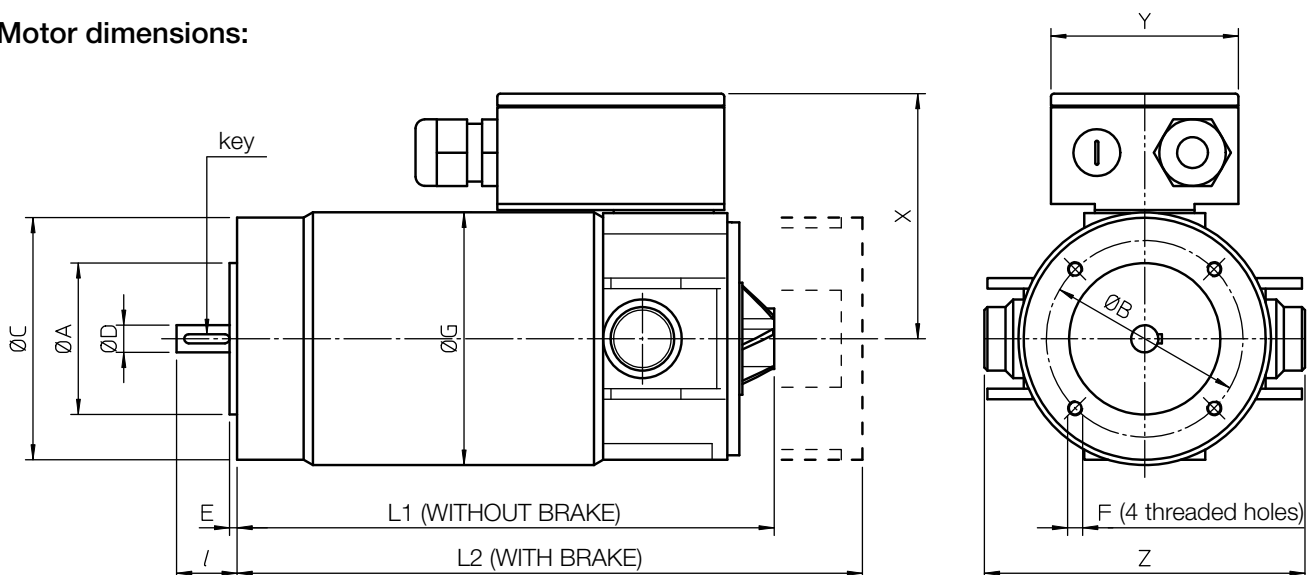

MOTOR	Ø A	Ø B	Ø C	Ø D	E	F	Ø G	l	key	L1	L2	X	Y	Z
100 W	50	65	80	9	2.5	M5	84	20	3×3×15	144	185	80	62	107
150 W	50	65	80	9	2.5	M5	84	20	3×3×15	177	218	80	62	107
300 W	60	75	90	11	2.5	M5	84	23	4×4×15	229	270	80	62	107
500 W	70	85	105	14	2.5	M6	84	30	5×5×20	322	364	80	62	107
750 W	80	100	120	19	3	M6	120	40	6×6×30	317	359	118	94	140

7.4 Brake motor: when it is required

- Ball screw linear actuators UBA Series: supplied as standard
- Ball screw linear actuators BSA Series and CLB series: on request, anyway it is always recommended
- Acme screw linear actuators UAL Series: on request
 - to help the actuator in stopping
 - to ensure positioning accuracy
 - to sustain the static load when the self-locking coefficient > 0.3
- Acme screw linear actuator ATL Series, CLA Series and TMA Series: on request
 - to ensure positioning accuracy
 - to sustain the static load when the self-locking coefficient > 0.3