

OVERALL DIMENSIONS

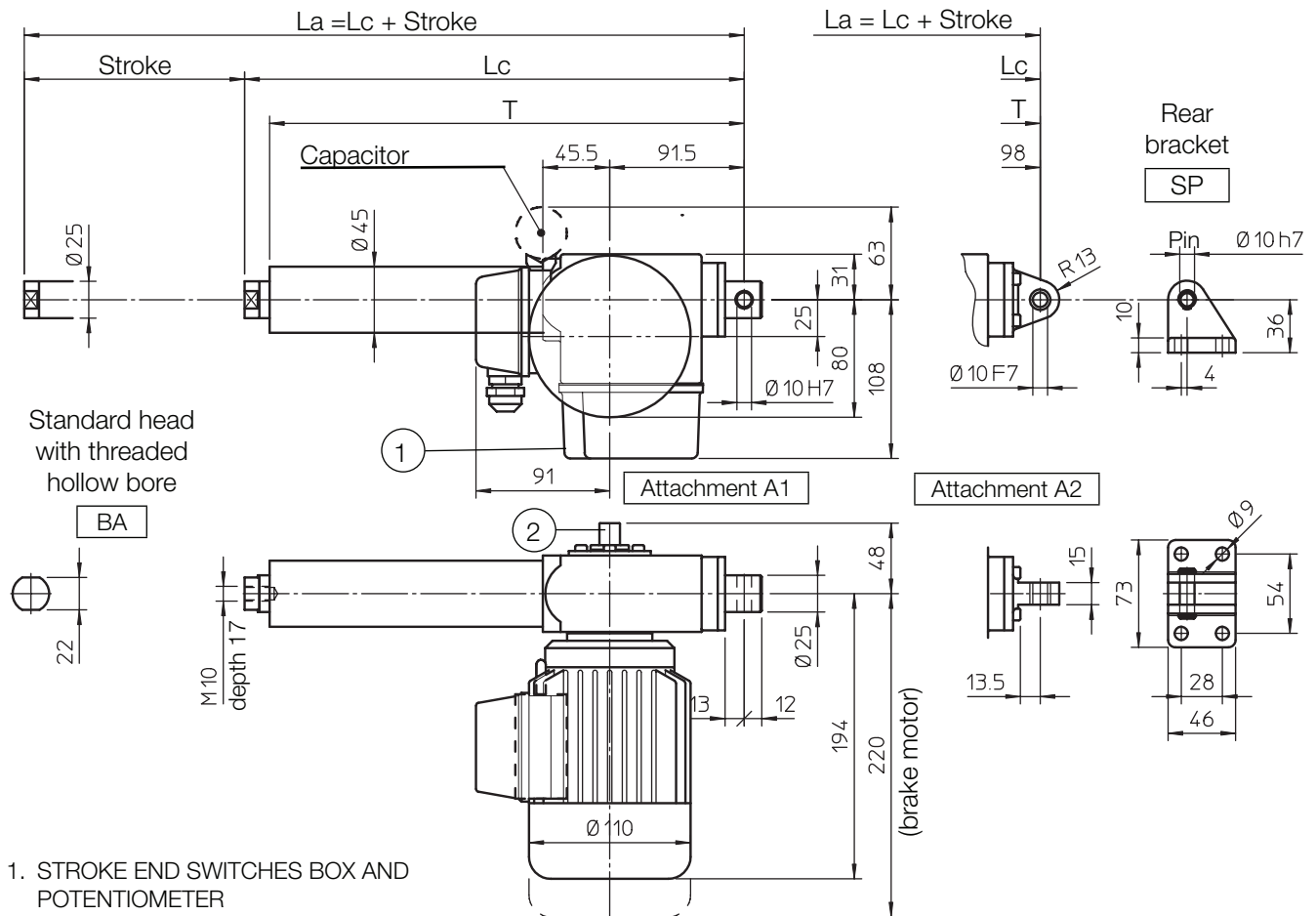

1. STROKE END SWITCHES BOX AND POTENTIOMETER
2. MOTOR SHAFT EXTENSION for:
Emergency manual activation
Stroke end switches and potentiometer adjustment

Q [mm]	Attachment A1	Attachment A2
	253	260

STROKE CODE	Actuator - Attachment A1				Actuator - Attachment A2				MASS [Kg]	
	STROKE [mm]	LENGTH [mm]		T [mm]	STROKE [mm]	LENGTH [mm]		T [mm]	standard motor	brake motor
C100	100	Lc [mm]	La [mm]	317	100	Lc [mm]	La [mm]	324	5.2	5.7
C150	150	348	448	367	150	355	455	374	5.3	5.8
C200	200	398	548	417	200	405	555	424	5.5	6.0
C250	250	448	648	467	250	455	655	474	5.6	6.1
C300	300	498	748	517	300	505	755	524	5.8	6.3
C400	400	548	848	567	400	555	855	574	6.1	6.6

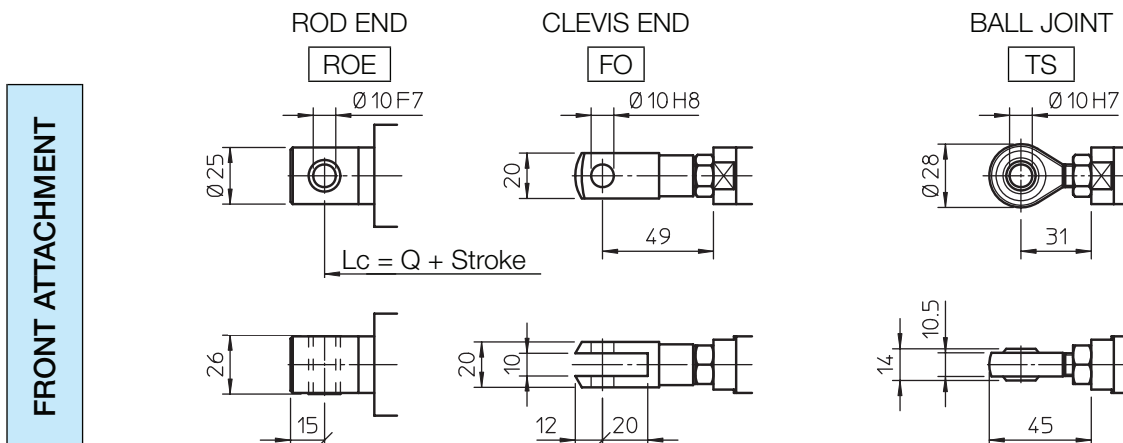

PERFORMANCES AND FEATURES

- Push load up to 5 000 N
- Pull load up to 4 000 N
- Linear speed up to 117 mm/s
- Standard stroke lengths:
100, 150, 200, 250, 300, 400 mm
- Ball screw BS 14 x 5 or BS 14 x 10
(technical details on page 66)
- Aluminium alloy housing
- Anodized aluminium outer tube
- Chrome-plated steel push rod – tolerance f7
- Rear attachment:
 - A1: zinc-plated steel rod end with bronze bush
 - A2: aluminium alloy with bronze bush
- Standard head BA or rod end ROE
in stainless steel AISI 303 with bronze bush
- AC 3-phase or 1-phase motor
(motor features details on page 70)
- Duty cycle with max load:
100% over 10 min at (-10 ... +40) °C
- Standard protection IP 55 (IP 54 with brake)
- Standard motor mounting position as per sketch
(right-hand, code RH)
- Long-life lubrication, maintenance free

ACCESSORIES

- Different front attachments
- Stainless steel push rod (code SS)
- Rear bracket (code SP)
with rear attachment A2
- Mechanical overload protection:
safety clutch (code FS)
- Brakemotor
- Adjustable electric stroke end switches (code FC2)
- Adjustable electric stroke end switches,
switching off the motor (code FC2X)
(not available with AC 3-phase motor)
- Extra switch for intermediate position (code FC)
- Rotative potentiometer 5kOhm for positioning control
(code POR5K)

NOTE: Extra limit switch and rotative potentiometer cannot be selected together

OPTIONS

- Motor mounting position on opposite side
(left-hand, code LH)
- Fixing attachment turned at 90° (code RPT 90)

PERFORMANCES with AC 3-phase 50 Hz 230/400 V or 1-phase 50 Hz 230 V motor

Ball screw BS 14 x 5				
RATIO	0.09 kW - 4 pole motor		0.12 kW - 2 pole motor	
	LOAD [N]	SPEED [mm/s]	LOAD [N]	SPEED [mm/s]
RH1	2170	29	1490	58
RV1	3270	19	2300	37
RN1	5000	9.5	4230	19
RL1	5000	4.5	5000	9.5
RXL1	5000	2.5	5000	4.5

Ball screw BS 14 x 10				
RATIO	0.09 kW - 4 pole motor		0.12 kW - 2 pole motor	
	LOAD [N]	SPEED [mm/s]	LOAD [N]	SPEED [mm/s]
RH2	1120	58	760	117
RV2	1730	37	1170	75
RN2	3100	19	2220	37
RL2	5000	9.5	3790	19

Self-locking conditions

Self-locking condition is achievable with brake motor only.

Information about statically self-locking conditions with pull or push load on page 68.

ORDERING CODE EXAMPLE

CLB 25	RL1	C200	CA 230/400 V	FC2	POR 5K				
Actuator	Selected ratio	Required stroke	Motor	Stroke end switches	Accessories			Options	

OVERALL DIMENSIONS

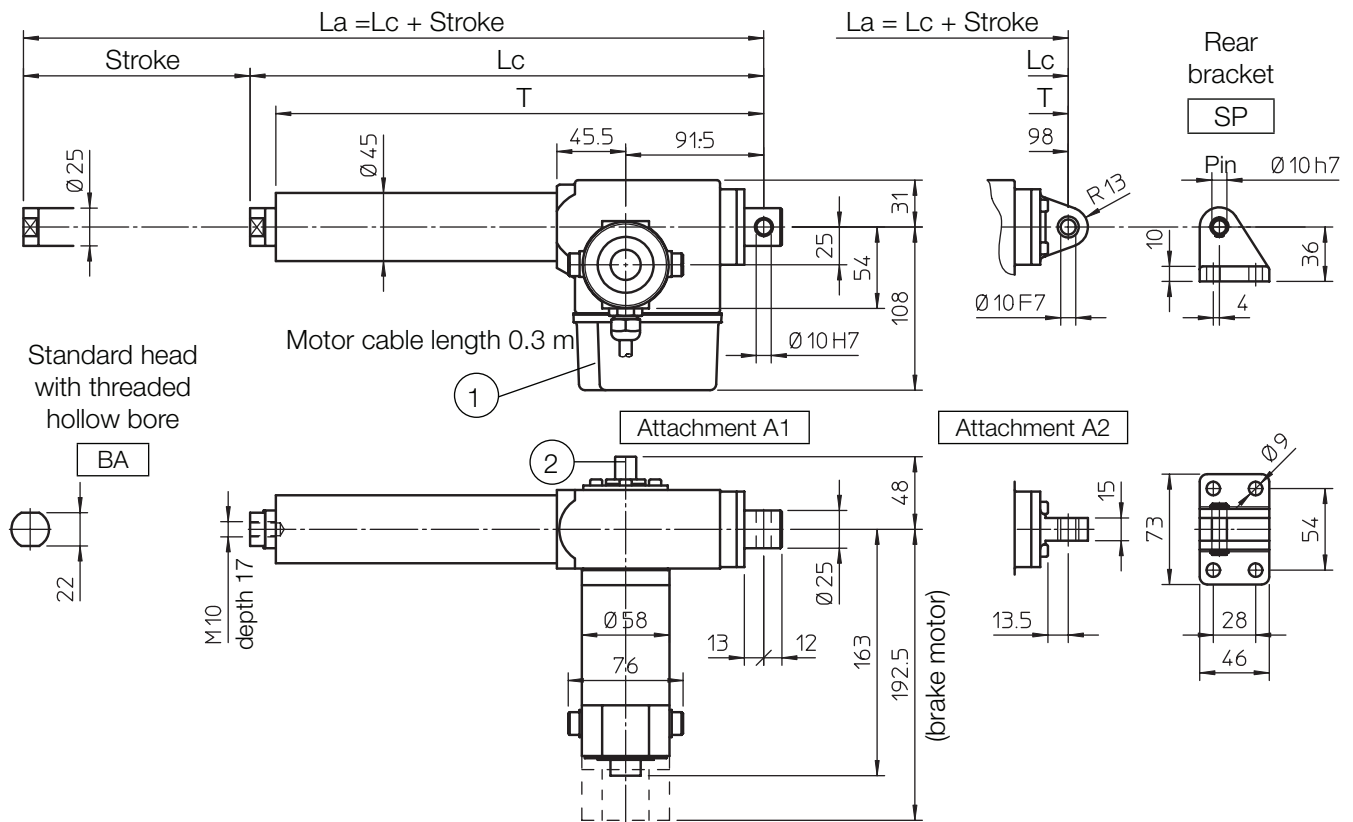

1. STROKE END SWITCHES BOX AND POTENTIOMETER
2. MOTOR SHAFT EXTENSION for:
 - Emergency manual activation
 - Stroke end switches and potentiometer adjustment

Q [mm]	Attachment A1	Attachment A2
	253	260

STROKE CODE	Actuator - Attachment A1			Actuator - Attachment A2			MASS [Kg]		
	STROKE [mm]	LENGTH Lc [mm]	LENGTH La [mm]	T [mm]	STROKE [mm]	LENGTH Lc [mm]		LENGTH La [mm]	T [mm]
C100	100	348	448	317	100	355	455	324	5.2
C150	150	398	548	367	150	405	555	374	5.3
C200	200	448	648	417	200	455	655	424	5.5
C250	250	498	748	467	250	505	755	474	5.6
C300	300	548	848	517	300	555	855	524	5.8
C400	400	648	1048	617	400	655	1055	624	6.1

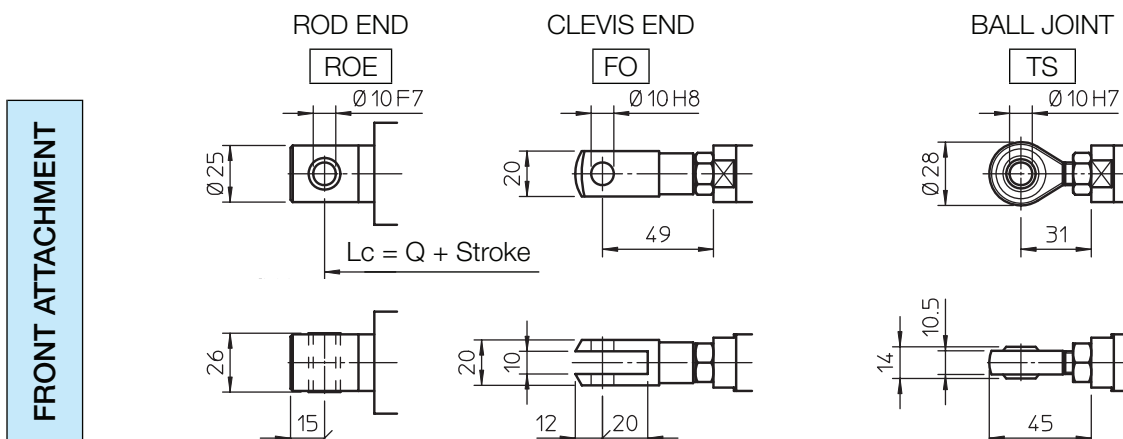

PERFORMANCES AND FEATURES

- Push load up to 5 000 N
- Pull load up to 4 000 N
- Linear speed up to 125 mm/s
- Standard stroke lengths:
100, 150, 200, 250, 300, 400 mm
- Ball screw BS 14 x 5 or BS 14 x 10
(technical details on page 66)
- Aluminium alloy housing
- Anodized aluminium outer tube
- Chrome-plated steel push rod – tolerance f7
- Rear attachment:
 - A1: zinc-plated steel rod end with bronze bush
 - A2: aluminium alloy with bronze bush
- Standard head BA or rod end ROE
in stainless steel AISI 303 with bronze bush
- 12 or 24 V DC brakemotor
(motor features details on page 69)
- Duty cycle with max load:
100% over 10 min at (-10 ... +40) °C
- Standard protection IP 54
- Standard motor mounting position as per sketch
(right-hand, code RH)
- Long-life lubrication, maintenance free

ACCESSORIES

- Different front attachments
- Stainless steel push rod (code SS)
- Rear bracket (code SP)
with rear attachment A2
- Mechanical overload protection:
safety clutch (code FS)
- Adjustable electric stroke end switches
(code FC2)
- Adjustable electric stroke end switches,
switching off the motor (code FC2X)
- Extra switch for intermediate position (code FC)
- Rotative potentiometer 5kOhm
for positioning control
(code POR5K)

NOTE: Extra limit switch and rotative potentiometer cannot be selected together

OPTIONS

- Motor mounting position on opposite side
(left-hand, code LH)
- Fixing attachment turned at 90° (code RPT 90)

PERFORMANCES with 24 V DC motor

(Performances with 12 V DC motor: same load, linear speed 10 % less, electrical consumption 2 times more)

Ball screw BS 14 x 5			
RATIO	LOAD [N]	SPEED [mm/s]	CURRENT [A]
RH1	800	63	4
RV1	1260	40	4
RN1	2350	20	4
RL1	4130	10	4
RXL1	5000	5	3

Ball screw BS 14 x 10			
RATIO	LOAD [N]	SPEED [mm/s]	CURRENT [A]
RH2	410	125	4
RV2	640	80	4
RN2	1200	40	4
RL2	2100	20	4

Self-locking conditions

Self-locking condition is achievable with brake motor only.

Information about statically self-locking conditions with pull or push load on page 68.

ORDERING CODE EXAMPLE

CLB 25	RL1	C200	CC 24 V	FC2	POR 5K				
Actuator	Selected ratio	Required stroke	Motor	Stroke end switches	Accessories			Options	

OVERALL DIMENSIONS

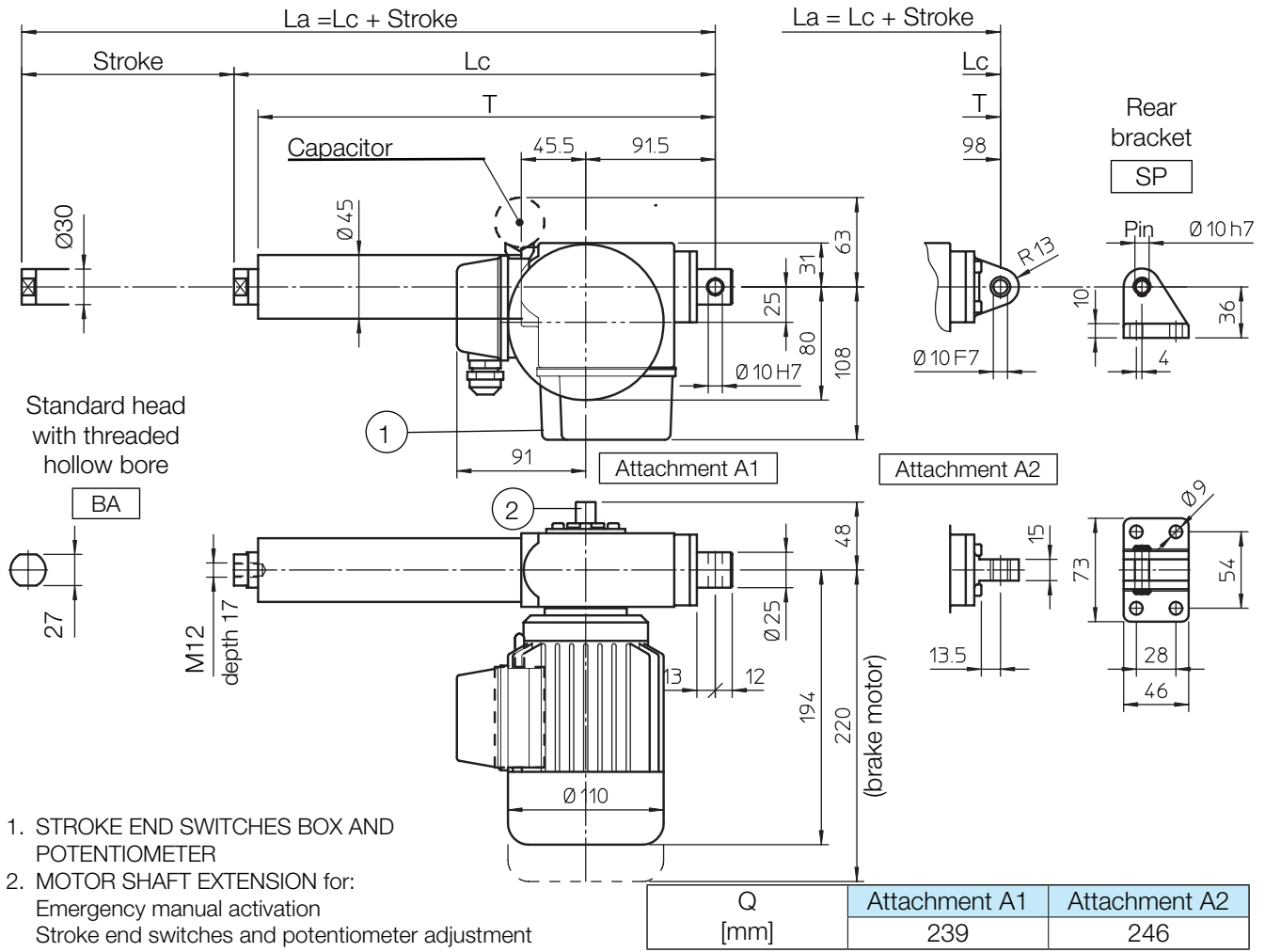

1. STROKE END SWITCHES BOX AND POTENTIOMETER
2. MOTOR SHAFT EXTENSION for:
Emergency manual activation
Stroke end switches and potentiometer adjustment

STROKE CODE	Actuator - Attachment A1				Actuator - Attachment A2				MASS [Kg]	
	STROKE [mm]	LENGTH		T [mm]	STROKE [mm]	LENGTH		T [mm]	standard motor	brake motor
		Lc [mm]	La [mm]			Lc [mm]	La [mm]			
C100	100	336	436	300	100	343	443	307	5.3	5.8
C150	150	386	536	350	150	393	543	357	5.5	6.0
C200	200	436	636	400	200	443	643	407	5.7	6.2
C300	300	536	836	500	300	543	843	507	6.1	6.6
C400	400	636	1036	600	400	643	1043	607	6.5	7.0
C500	500	736	1236	700	500	743	1243	707	6.9	7.4

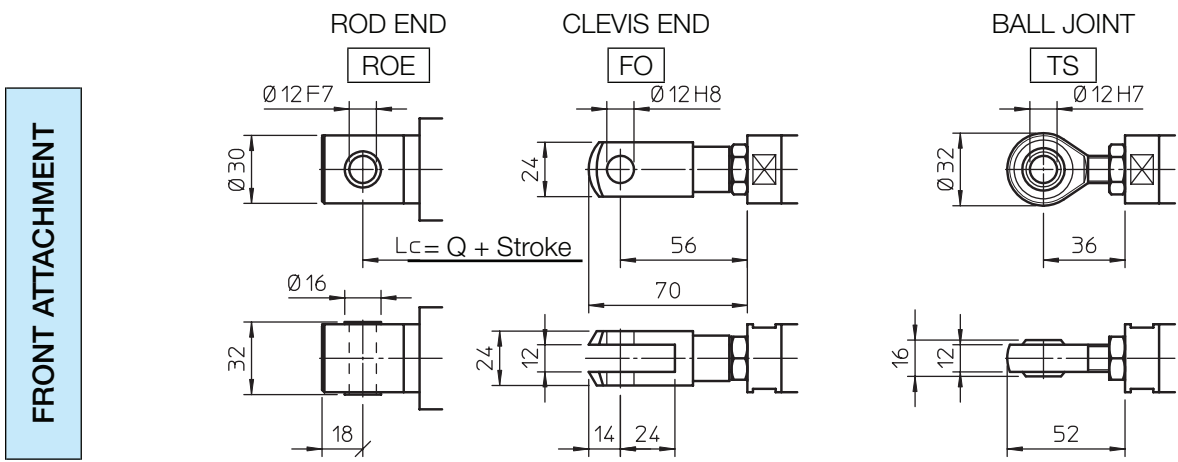

PERFORMANCES AND FEATURES

- Push load up to 7 000 N
- Pull load up to 4 000 N
- Linear speed up to 58 mm/s
- Standard stroke lengths:
100, 150, 200, 300, 400, 500 mm
- Ball screw BS 16 x 5 (technical details on page 66)
- Aluminium alloy housing
- Anodized aluminium outer tube
- Chrome-plated steel push rod
- Rear attachment:
 - A1: zinc-plated steel rod end with bronze bush
 - A2: aluminium alloy with bronze bush
- Standard head BA or rod end ROE
in stainless steel AISI 303 with bronze bush
- AC 3-phase or 1-phase motor
(motor features details on page 70)
- Duty cycle with max load:
100% over 10 min at (-10 ... +40) °C
- Standard protection IP 55 (IP 54 with brake)
- Standard motor mounting position as per sketch
(right-hand, code RH)
- Long-life lubrication, maintenance free

ACCESSORIES

- Different front attachments
- Stainless steel push rod (code SS)
- Rear bracket (code SP) with rear attachment A2
- Mechanical overload protection:
safety clutch (code FS)
- Brakemotor
- Adjustable electric stroke end switches (code FC2)
- Adjustable electric stroke end switches,
switching off the motor (code FC2X)
(not available with AC 3-phase motor)
- Extra switch for intermediate position (code FC)
- Rotative potentiometer 5kOhm for positioning control
(code POR5K)

NOTE: Extra limit switch and rotative potentiometer cannot be selected together

OPTIONS

- Motor mounting position on opposite side
(left-hand, code LH)
- Fixing attachment turned at 90° (code RPT 90)

PERFORMANCES with AC 3-phase 50 Hz 230/400 V or 1-phase 50 Hz 230 V motor

Ball screw BS 16 x 5				
RATIO	0.09 kW - 4 pole motor		0.12 kW - 2 pole motor	
	LOAD [N]	SPEED [mm/s]	LOAD [N]	SPEED [mm/s]
RH1	2160	29	1480	58
RV1	3260	19	2300	37
RN1	5990	9.5	4170	19
RL1	7000	4.5	7000	9.5

Self-locking conditions

Self-locking condition is achievable with brake motor only.

Information about statically self-locking conditions with pull or push load on page 68.

ORDERING CODE EXAMPLE

CLB 27	RL1	C200	CA 400 V	FC2	POR 5K				
Actuator	Selected ratio	Required stroke	Motor	Stroke end switches	Accessories			Options	