

UNIMEC bevel gearboxes have been designed and manufactured since 28 years using an in-the-van technology and mechanical solutions according to the state of the art to be able to meet the growing requirements of a demanding and sophisticated market. Nine sizes, tenths of mounting schemes, a range of serial ratios up to 1/12 and the possibility of a customized design having no equal, make of UNIMEC a reliable partner in the field of the motion transmission. The practical cubic shape of bevel gearboxes allows universal mounting possibilities on every kind of machines.

Bevel gear boxes

Bevel gearboxes are also very versatile with regard to the shafts choice and the possibility of a direct mounting on any kind of motors, from the normal IEC to brushless motors, to pneumatic motors and so on. High running efficiency, low noise are the logical consequences of the application of Gleason® type spiral teeth conical gears; the use of this kind of geometry and suitable thermal treatments place UNIMEC's bevel gearboxes on top of this mechanical sector.

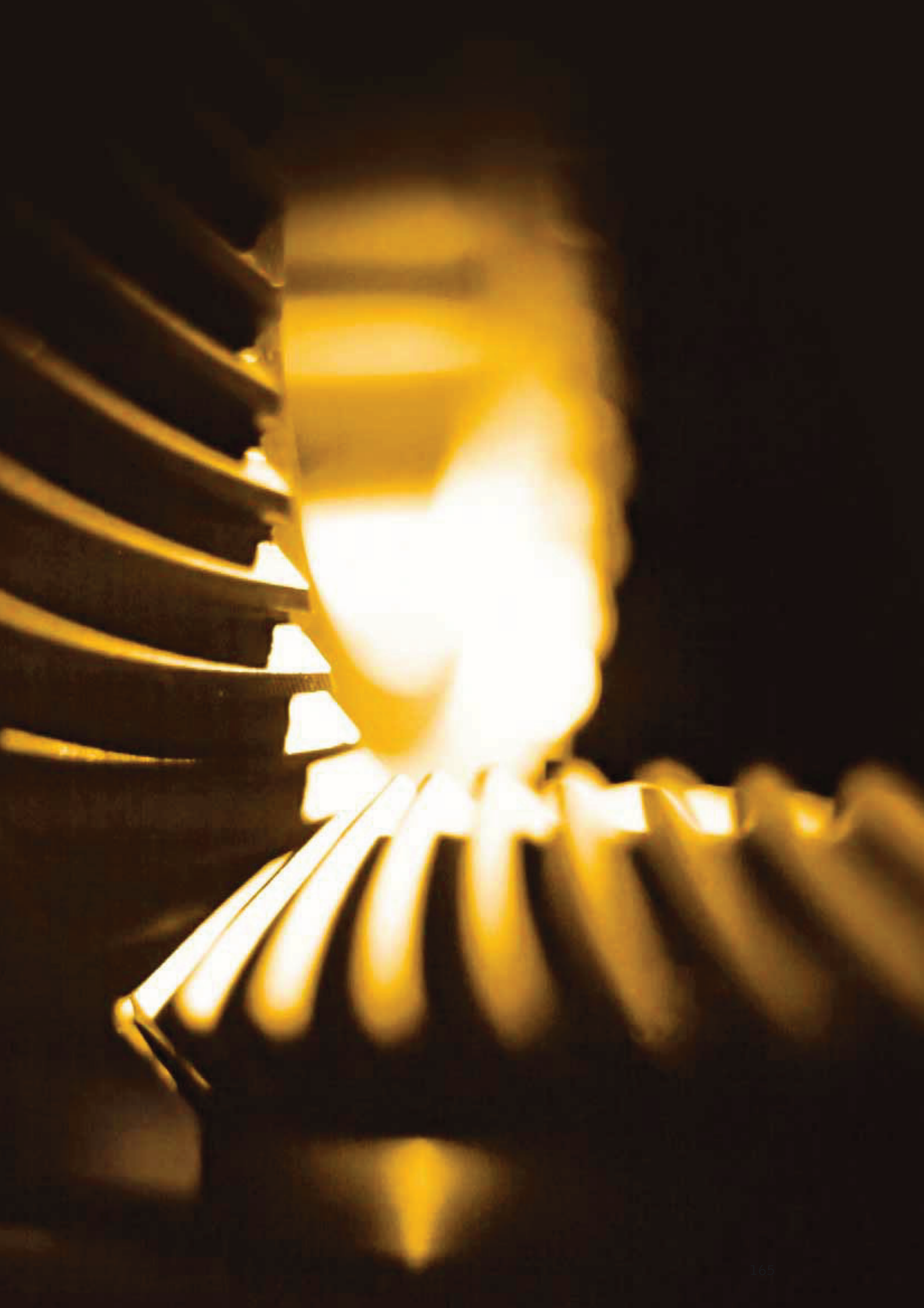



**198 RC**

Hollow shaft bevel gearboxes.
Ratios:
1/1 - 1/1,5 - 1/2 - 1/3 - 1/4.

**199 RR**

Hollow shaft bevel gearboxes with reinforced hub shaft.
Ratios:
1/1 - 1/1,5 - 1/2 - 1/3 - 1/4.

**200 RB**

Broached hollow shaft bevel gearboxes
Ratios:
1/1 - 1/1,5 - 1/2 - 1/3 - 1/4.

**201 RA**

Hollow shaft bevel gearboxes with shrink-disks.
Ratios:
1/1 - 1/1,5 - 1/2 - 1/3 - 1/4.

**202 RS**

Protruding shaft bevel gearboxes.
Ratios:
1/1 - 1/1,5 - 1/2 - 1/3 - 1/4.

**203 RP**

Protruding shaft bevel gearboxes with reinforced hub shaft.
Ratios:
1/1 - 1/1,5 - 1/2 - 1/3 - 1/4.

**204 RX**

Double hub bevel gearboxes.
Ratios:
1/1 - 1/1,5 - 1/2 - 1/3 - 1/4.

**205 RZ**

Double hub bevel gearboxes with reinforced shafts.
Ratios:
1/1 - 1/1,5 - 1/2 - 1/3 - 1/4.



RM 206
 Bevel gearboxes with fast double shaft – multiplier version.
 Ratios: 1/1,5.



REA 210
 High reduction hollow shaft bevel gearboxes with shrink-disks.
 Ratios: 1/4,5 - 1/6 - 1/9 - 1/12.



RIS 207
 Protruding shaft bevel gearboxes with inverter.
 Ratios: 1/1 - 1/2.



RES 211
 High reduction bevel gearboxes with protruding shaft.
 Ratios: 1/4,5 - 1/6 - 1/9 - 1/12.



REC 208
 High reduction bevel gearboxes with hollow shaft.
 Ratios: 1/4,5 - 1/6 - 1/9 - 1/12.



RHC 212
 Inverted bevel gearboxes with hollow shaft.
 Ratios: 1/2 - 1/3.



REB 209
 High reduction bevel gearboxes with broached hollow shaft.
 Ratios: 1/4,5 - 1/6 - 1/9 - 1/12.





213 RHB

Inverted gearboxes with broached hollow shaft.
Ratios:
1/2 - 1/3.



217 MRB

Broached hollow shaft motor-gearboxes.
Ratios:
1/1 - 1/1,5 - 1/2 - 1/3 - 1/4.



214 RHA

Inverted bevel gearboxes with hollow shaft with shrink-disks.
Ratios:
1/2 - 1/3.



218 MRA

Hollow shaft motor-gearboxes with shrink-disks.
Ratios:
1/1 - 1/1,5 - 1/2 - 1/3 - 1/4.



215 RHS

Inverted bevel gearboxes with protruding shaft.
Ratios:
1/2 - 1/3 - 1/4,5.



219 MRS

Protruding shaft motor-gearboxes.
Ratios:
1/1 - 1/1,5 - 1/2 - 1/3 - 1/4.



216 MRC

Hollow shaft motor-gearboxes.
Ratios:
1/1 - 1/1,5 - 1/2 - 1/3 - 1/4.



220 MRX

Two hub shafts motor-gearboxes.
Ratios:
1/1 - 1/1,5 - 1/2 - 1/3 - 1/4.



MRZ 221

Two hub shafts bevel gearboxes with reinforced shaft.
Ratios:
1/1 - 1/1,5 - 1/2 - 1/3 - 1/4.



Special bevel gearboxes



MRE 222

High reduction motor-gearboxes.
Ratios:
1/4,5 - 1/6 - 1/9 - 1/12.



Bevel gearboxes with clamps on the motor shaft



Bevel gearboxes

Casings

Bevel gearboxes casings have a cubic base form, with six completely machine finished outer faces and varnished inner parts. Each face is supplied with mounting holes, while the finished hubs and flanges show outer tolerance centerings. The casing are made of grey cast iron EN-GJL-250 (according to the UNI EN 1561:1998 requirements), except for size 500 whose casing is made of electro-welded carbon steel S235J0 (according to the UNI EN 10025-2:2005 requirements).

Gears

All the gears are alloy steel 17NiCrMo 6-4 (according to the UNI EN 10084:2000 requirements). They have a Gleason® type helicoidal geometry toothing, with variable helix angle depending on the ratio for a better meshing and an optimum torque distribution. The bevel gear set undergo thermal treatments like case-hardening, and carburizing and then they are run-in in couples with marking of the contact point; all this allows a perfect and noiseless meshing. All the gears planes and holes undergo a grinding process.

Shafts

The bevel gearboxes protruding shafts are made of carbon steel C45 (according to the UNI EN 10083-2:1998 requirements); the hollow shafts on the contrary are made of steel 16NiCr4 (according to the UNI EN 10084:2000 requirements), and they undergo case-hardening, carburizing and grinding treatments for their inner diameters. All shafts are induction ground and case-hardened in the contact area with the seals. A wide range of geometries is available for the shafts: hollow shafts with key, broached or for shrink-disks, protruding or over-size.

Bearings and market materials

Top-quality bearings and market materials are used for the whole line. All UNIMEC's bevel gear boxes are adapted to conical roller bearings, excluded sizes 54 and 86, for which ball bearings are foreseen.

Weight

(referred to base models)

Size	54	86	110	134	166	200	250	350	500	32	42	55
Weight [kg]	2	6,5	10	19	32	55	103	173	1050	29	48	82



GLOSSARY

A	=	maximum input angular speed [rpm]
B	=	frequency of the loading cycle [Hz]
C_p	=	specific heat of lubricant [J/Kg·°C]
F_{r1}	=	radial force on the hub shaft [daN]
F_{r2}	=	radial force on the double shaft (Protrusion next to the gear) [daN]
F_{r3}	=	radial force on the double shaft (protrusion far from the gear) [daN]
F_{a1}	=	axial compression force on the hub shaft [daN]
F_{a2}	=	axial traction force on the hub shaft [daN]
F_{a3}	=	axial compression force on the double shaft [daN]
F_{a4}	=	axial traction force on the double shaft [daN]
f_a	=	ambient factor
f_d	=	duration factor
f_g	=	usage factor
i	=	reduction ratio, meant as a fraction (es.1/2)
J	=	total inertia [kgm ²]
J_r	=	bevel gearbox inertia [kgm ²]
J_v	=	inertia downstream of the bevel gearbox [kgm ²]
M_{tL}	=	torque on the slow shaft [daNm]
M_{tv}	=	torque on the fast shaft [daNm]
n_1	=	fast shaft
n_2	=	slow shaft
P_d	=	power dissipated in the form of heat [kW]
P_i	=	input power to the single bevel gearbox [kW]
P_L	=	power on the slow shaft [kW]
P_v	=	power on the fast shaft [kW]
P_j	=	inertia power [kW]
P_u	=	output power to the single bevel gearbox [kW]
P_e	=	equivalent power [kW]
PTC	=	adjustment factor on thermal power
Q	=	lubricant flow-rate [litre/min]
rpm	=	rounds per minute
t_a	=	ambient temperature [°C]
t_r	=	bevel gearbox surface temperature [°C]
η	=	bevel gearbox running efficiency
ω_L	=	slow shaft angular speed [rpm]
ω_v	=	fast shaft angular speed [rpm]
α_L	=	angular acceleration of the slow shaft [rad/s ²]

Unless otherwise specified all tables show linear measurements expressed in [mm].
All the reduction ratios are expressed in the form of a fraction, unless otherwise specified.

LOAD ANALYSIS AND COMPOSITION

The aim of a bevel gearbox is to transmit power through shafts being orthogonal the one to the other; for this reason the gears, the shafts and the bearings have been designed to transmit powers and torques as shown in the power tables. Nevertheless there can also be other forces which have to be considered during the dimensioning phase of bevel gearboxes.

Such loads are generated by the devices connected to the bevel gearbox and they can be caused by belt drives, sudden accelerations and decelerations of the flywheels, structure misalignments, vibrations, shocks, pendular cycles etc. There can be two types of loads acting on the shafts: radial and axial loads, as referred to the shaft axis itself. The tables below show the maximum values for each type of forces according to the model and the size. In case of heavy loads, the table values must be divided by 1,5, while in case of shock load they should be divided by 2.

In case real load do not approach to the table values (modified) it is advisable to contact the technical office.

RADIAL LOADS



		RC	RB	RA	RS	RX	RM	RIS		
Size		54	86	110	134	166	200	250	350	500
Conditions	Revolution speed of the fast shaft									
	ω_v [rpm]									
Dynamic	50 F_{r1} [daN]	53	109	160	245	476	846	1663	2441	4150
	3000	15	34	135	232	270	384	534	930	1580
Static	F_{r1} [daN]	100	204	300	460	893	1586	3118	4577	7780

		RR	RP	RZ						
Size		86	110	134	166	200	250	350	500	
Conditions	Revolution speed of the fast shaft									
	ω_v [rpm]									
Dynamic	50 F_{r1} [daN]	316	351	524	1045	1297	2459	3184	5412	
	3000	135	179	232	305	379	718	930	1580	
Static	F_{r1} [daN]	592	658	982	2100	3326	5715	8373	14235	

		REC	REB	REA	RES			
Size		32	42	55				
Conditions	Revolution speed of the fast shaft							
	ω_v [rpm]							
Dynamic	50 F_{r1} [daN]	245	476	846				
	3000	232	270	384				
Static	F_{r1} [daN]	460	893	1586				

		RHC	RHB	RHA	RHS			
Size		32	42	55	32	42	55	
Ratio		1/2 - 1/3			1/4,5			
Conditions	Revolution speed of the fast shaft							
	ω_v [rpm]							
Dynamic	50 F_{r1} [daN]	477	610	927	596	762	1158	
	3000	151	198	295	151	198	295	
Static	F_{r1} [daN]	982	2000	3838	684	2019	3838	



RC RR RB RA RS RP										
Size		54	86	110	134	166	200	250	350	500
Conditions	Revolution speed of the fast shaft									
	ω_v [rpm]									
Dynamic	50 Fr2 [daN]	40	144	351	462	788	953	1444	2784	4732
	3000	10	36	105	135	230	278	421	813	1382
Dynamic	50 Fr3 [daN]	68	241	351	524	1121	1588	2406	4466	7592
	3000	17	61	176	225	384	464	703	1356	2300
Static	Fr2-Fr3 [daN]	349	592	658	982	2100	3326	5715	8373	14234



RM RIS										
Size		54	86	110	134	166	200	250	350	500
Conditions	Revolution speed of the fast shaft									
	ω_v [rpm]									
Dynamic	50 Fr2 [daN]	26	109	160	245	441	561	1044	2441	4150
	3000	5	47	70	94	128	163	421	813	1382
Dynamic	50 Fr3 [daN]	42	109	160	245	476	846	1663	2441	4150
	3000	9	78	117	156	266	273	706	1356	2300
Static	Fr2-Fr3 [daN]	110	204	300	460	893	1586	3118	4577	7780

REC REB REA RES											
Size							32	42	55		
Conditions	Revolution speed of the fast shaft										
	ω_v [rpm]										
Dynamic	50 Fr2 [daN]						462	788	953		
	3000						204	348	421		
Dynamic	50 Fr3 [daN]						524	1121	1588		
	3000						341	582	703		
Static	Fr2-Fr3 [daN]						982	2100	3326		

RHC RHB RHA RHS										
Size		32			42			55		
Ratio		1/2 - 1/3			1/4,5					
Conditions	Revolution speed of the fast shaft									
	ω_v [rpm]									
Dynamic	50 Fr2 [daN]	462			788			953		
	3000	135			230			278		
Dynamic	50 Fr3 [daN]	524			1121			1588		
	3000	225			384			464		
Static	Fr2-Fr3 [daN]	982			2100			3326		

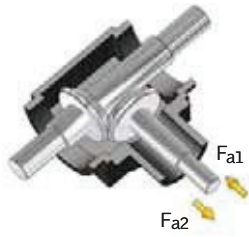

AXIAL LOADS

RC RB RA RS RX RM RIS		54	86	110	134	166	200	250	350	500
Conditions	Revolution speed of the fast shaft									
	ω_v [rpm]									
Dynamic	50 F_{a1} [daN]	59	136	463	794	926	1314	1828	3184	5412
	3000	15	34	135	232	270	384	534	930	1581
Dynamic	50 F_{a2} [daN]	35	81	278	476	555	788	1097	1910	3247
	3000	9	20	81	139	162	230	320	558	948
Static	F_{a1} [daN]	71	327	2327	4153	4250	6535	8733	21538	36614
Static	F_{a2} [daN]	71	327	2044	3464	4250	5196	7830	21538	36614

RR RP RZ		86	110	134	166	200	250	350	500
Conditions	Revolution speed of the fast shaft								
	ω_v [rpm]								
Dynamic	50 F_{a1} [daN]	463	615	794	1045	1297	2459	3184	5412
	3000	135	179	232	305	379	718	930	1581
Dynamic	50 F_{a2} [daN]	278	368	476	627	778	1475	1910	3247
	3000	81	107	139	183	227	431	558	948
Static	F_{a1} [daN]	1060	1620	2670	5700	6300	8600	21538	36614
Static	F_{a2} [daN]	1656	2044	3464	4150	5196	7830	21538	36614

REC REB REA RES		32	42	55
Conditions	Revolution speed of the fast shaft			
	ω_v [rpm]			
Dynamic	50 F_{a1} [daN]	794	926	1314
	3000	232	270	384
Dynamic	50 F_{a2} [daN]	476	555	788
	3000	139	162	230
Static	F_{a1} [daN]	4153	4250	6535
Static	F_{a2} [daN]	3464	4250	5196

RHC RHB RHA RHS		32	42	55	32	42	55
Ratio		1/2 - 1/3			1/4,5		
Conditions	Revolution speed of the fast shaft						
	ω_v [rpm]						
Dynamic	50 F_{a1} [daN]	477	610	927	477	610	927
	3000	152	197	298	152	197	298
Dynamic	50 F_{a2} [daN]	477	610	927	477	610	927
	3000	152	197	298	152	197	298
Static	F_{a1} [daN]	1100	1520	3400	1100	1520	3400
Static	F_{a2} [daN]	1100	1520	3400	1100	1520	3400



RC RR RB RA RS RP											
Size			54	86	110	134	166	200	250	350	500
Conditions	Revolution speed										
	of the fast shaft										
	ω_v [rpm]										
Dynamic	50	F_{a3} [daN]	68	241	604	770	1314	1588	2406	4641	7889
	3000		17	61	176	225	384	464	703	1356	2305
Dynamic	50	F_{a4} [daN]	40	144	362	462	788	953	1444	2784	4732
	3000		10	36	105	135	230	278	421	813	1382
Static		F_{a3-Fa4} [daN]	182	580	2044	3464	4330	5196	7830	22320	37944

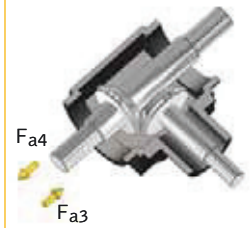

RM RIS											
Size			86	110	134	166	200	250	350	500	
Conditions	Revolution speed										
	of the fast shaft										
	ω_v [rpm]										
Dynamic	50	F_{a3} [daN]		268	402	536	912	935	2406	4641	7889
	3000			78	117	156	266	273	703	1356	2305
Dynamic	50	F_{a4} [daN]		161	241	322	441	561	1444	2784	4732
	3000			47	70	94	128	163	421	813	1382
Static		F_{a3-Fa4} [daN]		1094	1622	2150	3464	5196	7830	22320	37944

REC REB REA RES										
Size								32	42	55
Conditions	Revolution speed									
	of the fast shaft									
	ω_v [rpm]									
Dynamic	50	F_{a3} [daN]						770	1314	1588
	3000							341	582	703
Dynamic	50	F_{a4} [daN]						462	788	953
	3000							204	348	421
Static		F_{a3-Fa4} [daN]						3464	4330	5196

RHC RHB RHA RHS										
Size			32	42	55		32	42	55	
Ratio			1/2 - 1/3				1/4,5			
Conditions	Revolution speed									
	of the fast shaft									
	ω_v [rpm]									
Dynamic	50	F_{a3} [daN]		770	1314	1588		536	912	935
	3000			225	384	464		156	266	273
Dynamic	50	F_{a4} [daN]		462	788	953		322	441	561
	3000			135	230	278		94	128	163
Static		F_{a3-Fa4} [daN]		3464	4330	5196		2150	3464	5196

BACKLASH

The gears connection presents a natural and necessary backlash which is transmitted to the shafts. A particular care in the assembly allows to keep such value within 15'-20'. For particular applications, where the standard backlash should be further reduced, it is possible to reach a maximum value comprised between 5'-7'. It is important to remember that an excessive backlash reduction could induce the transmission to be blocked due to the interference between the gears. Furthermore, a too tight backlash would cause friction phenomena and consequently an efficiency reduction as well as an heating of the transmission.

The gears backlash tends to increase according to the wear ratio of the components, that is why after various running cycles we can logically expect an higher value than the value taken before the start-up. Finally it should be reminded that, due to the axial components of the transmission forces, the backlash measured under load can be different than the value taken when the bevel gearbox is unloaded. In case a very high precision is requested, it is advisable to mount shrink disks, both on the output and on the input shafts, because among standard couplings it is the only one ensuring a minimum backlash for the mounting on the machine.

RUNNING EFFICIENCY

As the aim of a bevel gearbox is to transmit power, it is necessary for its running efficiency to be the maximum possible, in order to minimize the loss of power transformed into heat. The meshing precision allows a gear pair running efficiency of 97%. The overall transmission running efficiency reaches 90% due to the lubricant splash and the sliding of the rotating devices, such as bearings and shafts. During the first operation hours the running efficiency could be lower than indicated; after a suitable run-in the power which had been lost in friction should reach a value towards 10%.



HANDLING

All bevel gearboxes can be manually operated. Anyway most part of its application foresees a motorized handling, in many cases even direct. For the sizes from 86 to 250 included, it is possible to connect directly a standard IEC motor to the fast shaft of the bevel gearbox. Special flanges can be provided for all sizes made for hydraulic, pneumatic, brushless motors, as well as for direct current motors, permanent magnet motors, stepper motors and other special motors. It is also possible to realize special flanges for fixing the drive shaft by means of a shrink disk, in order to minimize the transmission backlash. The power tables determine the motoring power and the torque on the slow shaft, for each single bevel gearbox, in case of unique service factors, according to the model, size, ratio and revolution speeds.

Rotation directions

The rotation directions depend on the mounting scheme. According to the chosen model, as a function of the required rotation direction, it's possible to choose the mounting scheme which best meets those requirements. We remind that, even if one only rotation direction of a shaft is changed from clockwise into anti-clockwise (and vice-versa), any other rotations of the bevel gearbox shafts direction must be reversed.

Non-stop operation

A non-stop operation occurs when the speed modulation gear is subjected to time constant torque and angular speed. After a transition period the revolutions become stationary, together with the surface temperature of the bevel gearbox and the ambient thermal exchange. It is important to check for wear phenomena and thermal power.

Intermittent operation

An intermittent operation occurs when high grade accelerations and deceleration overlap a revolution speed and torque (even at zero value), make it necessary to verify the ability to counteract the system inertia. A revision of the bevel gearbox and the input power is therefore necessary. It is important to check bending and fatigue strength parameters.

The key phase

Because of gears have a discrete teeth number, keys on shaft will never be perfectly on phase as shown in drawings. Phasing precision changes in function of ratio and size, as reported in the following table.

Ratio	54	86	110	134	166	200	250	350	500
1/1	± 8°	± 6,5°	± 5,5°	± 6,5°	± 6,5°	± 6,5°	± 6°	± 4°	± 4°
1/1,5	± 5°	± 6°	± 5,5°	± 5,5°	± 6°	± 5,5°	± 5,5°	± 4°	± 4°
1/2	± 5°	± 6°	± 6°	± 6,5°	± 6,5°	± 6,5°	± 6°	± 4°	± 4°
1/3	± 5°	± 6°	± 4,5°	± 5,5°	± 5°	± 5°	± 5°	± 3,5°	± 3,5°
1/4	± 5°	± 4,5°	± 4,5°	± 4,5°	± 4,5°	± 4°	± 4,5°	± 3,5°	± 3,5°

If there's the need of a higher precision, it's necessary to proceed with a special assembling.

LUBRICATION

The lubrication of the inner transmission devices (gears and bearings) is made using a mineral oil with extreme pressure additive: TOTAL CARTER EP 220. For size 54 the adopted lubricant is TOTAL CERAN CA. For a proper operation of the transmission **it is advisable to steady check for lubricant leakage**. For all sizes a plug for lubricant filling-up is foreseen. The technical specifications and the application field for the lubricant inside the bevel gearboxes are listed below.

Lubricant	Application field	Operating temperature [°C]*	Technical specifications
Total Carter EP 220 (not compatible with polyglycol oils)	standard	0 : +200	AGMA 9005: D24 DIN 51517-3: CLP NF ISO 6743-6: CKD
Total Ceran CA	standard (54)	-15 : +130	DIN 51502:0GPON -25 ISO 6743-9: L-XBDIB 0
Total Azolla ZS 68	High speeds**	-10 : +200	AFNOR NF E 48-603 HM DIN 51524-2: HLP ISO 6743-4: HM
Total Dacnis SH 100	High temperatures	-30 : +250	NF ISO 6743: DAJ
Total Nevastane SL 220	Food industry	-30 : +230	NSF-USDA: H1

* for operation temperatures between 80°C and 150°C Viton® seals should be used; for temperatures higher than 150°C and lower -20°C it is advisable to contact our technical office.

** for input revolutions higher than 1500 rpm we suggest using Viton® seals in order to better counteract the local temperature increases due to the strong sliding on the seals.

The quantity of lubricant contained in bevel gearboxes is shown in the following table.

Size	54	86	110	134	166	200	250	350	500	32	42	55
Inner lubricant quantity [litres]	0,015	0,1	0,2	0,4	0,9	1,5	3,1	11	28	1	1,8	3,7

The inner devices of the bevel gearboxes can be lubricated in two ways: by means of splash or forced lubrication. Splash lubrication does not require external interventions: when the fast shaft revolutions are lower than indicated in the graph below, its operation ensures that lubricant reaches all the components requiring lubrication. For revolution speeds higher than the indicated values, it may happen that the gears peripheral speed be such as to create centrifugal forces able to overcome the lubricant adhesivity. Therefore, in order to ensure a proper lubrication, a lubricant feeding under pressure is necessary (we suggest 5 bar) by means of a suitable oil cooling circuit. **In case of forced lubrication it will be necessary to precise the mounting position and localization of the holes to be provided for the connection to the lubrication circuit.**



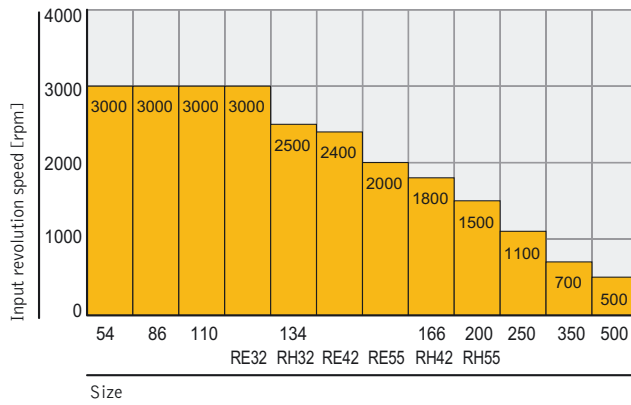

For revolutions reaching the border values indicated in the above graph it is advisable to contact our technical office in order to evaluate the modus operandi.

For very low revolutions of the fast shaft (lower than 50 rpm) the phenomena which normally generate splash could not be triggered off in a correct way. We suggest contacting our technical office in order to evaluate the most suitable solution to the problem.

In case of vertical axis mounting, the upper bearings and gears could not be properly lubricated. It is therefore necessary to indicate such situation in case of order, so that suitable grease holes can be foreseen. If no indication about lubrication is given at the ordering phase, it is understood that the application conditions fall within the conditions of an horizontal mounting with splash lubrication.

INSTALLATION AND MAINTENANCE

Installation

When positioning the bevel gearboxes and connecting them to the machines, the greatest of care is necessary in the alignment of the axes. In case of an imprecise alignment, the bearing would be overloaded, anomalous overheated, and it would be subjected to a greater wear with a consequent lifetime reduction and a noise increase. The transmission should be mounted so that movements and vibrations are avoided, and they should be properly fixed by means of bolts. We suggest effecting a proper cleaning and lubrication of the contact surfaces before assembling the connecting members, in order that any seizure or oxidizing problems be avoided. The assembly or disassembly must be carried out using tie rods and extractors through the threaded bore at the end of the shaft. For tight fittings, a shrink assembly is recommended, heating the members to be shrunk on to 80-100°C. Thanks to their particular cubic box form, bevel gearboxes can be mounted in any position. It should be given previous notice in case of a vertical mounting in order that a proper lubrication be foreseen.

Preparing for service

All speed modulation gears are supplied filled with long lasting lubricant which ensures a perfect operation of the unit according to the power values indicated in the catalogue. The only exception is represented by the ones having an "add oil" label. The lubricant filling up to the right level is an installer's responsibility and it must be carried out when the gears are not in motion. An excessive filling should be avoided in order that any overheating, noise, inner pressure loss and power loss occur.

Start-up

All the units undergo a brief testing before being delivered to the client. However, several hours of running at full load are necessary before the bevel gearbox reaches its full running efficiency. In case of need, the bevel gearbox can be immediately set to work at full load; but, circumstances permitting, it is nonetheless advisable to subject it to a gradually increasing load to reach maximum load after 20 - 30 hours of running. It is also vital to take the precautions necessary to avoid overloading in the first stages of running. The temperatures reached by the bevel gearbox in these initial phases will be higher than the ones produced after the complete running-in of the same.

Routine maintenance

Bevel gearboxes must be inspected once a month. Lubricant leakage should be checked for, and in case the oil level should be restored and the seals replaced. The lubricant control must be effected when the speed modulation gear is not working. The oil should be changed at intervals which will vary according to the working conditions; generally, in normal conditions and at the normal operation temperatures, it should be possible to obtain a minimum lubricant lifetime of 10.000 hours.

Storage

The bevel gearboxes must be protected from deposits of dust and foreign matter during storage. Particular attention must be paid to saline or corrosive atmospheres.

We also recommend to:

- Periodically rotate the shafts to ensure proper lubrication of inner parts and avoid that the seals dry up, therefore causing lubricant leakage.
- For bevel gearboxes without lubricant completely fill-in the unit with rustproof oil. When servicing for use, completely empty the oil and refill with the recommended oil to the correct level.
- Protect the shafts with suitable products.

Warranty

The warranty is valid only when the instructions contained in our manual are carefully followed.



ORDERING CODES

RC	86	C1	1/1
model	size	construction model	ratio

Models: RC - RR - RB - RA - RS - RP - RX - RZ - RM* - RIS and motorized

- 1 Casing
- 2 Cover
- 3 Hub
- 3.1 Motor flange
- 4 Shaft (hollow-protruding-broached - with shrink disk)
- 5 Bevel gear
- 5.1 Bevel pinion
- 6 Hub shaft
- 6.1 Drive shaft
- 7 Spacer
- 8 Gasket
- 8.1 Gasket for motorisation
- 9 Lock washer
- 10 Bearing
- 10.1 Bearing for motorisation
- 11 Bearing
- 12 Stop ring
- 12.1 Stop ring for motorisation
- 13 Seal
- 13.1 Seal for motorisation
- 14 Seal
- 15 Key
- 16 Key
- 17 Bolt
- 18 Washer
- 19 Bolt
- 20 Filling plug
- 21 Hub cover
- (sizes 166 - 200 - 250 - 350 - 500)
- 22 Bolt
- (sizes 166 - 200 - 250 - 350 - 500)

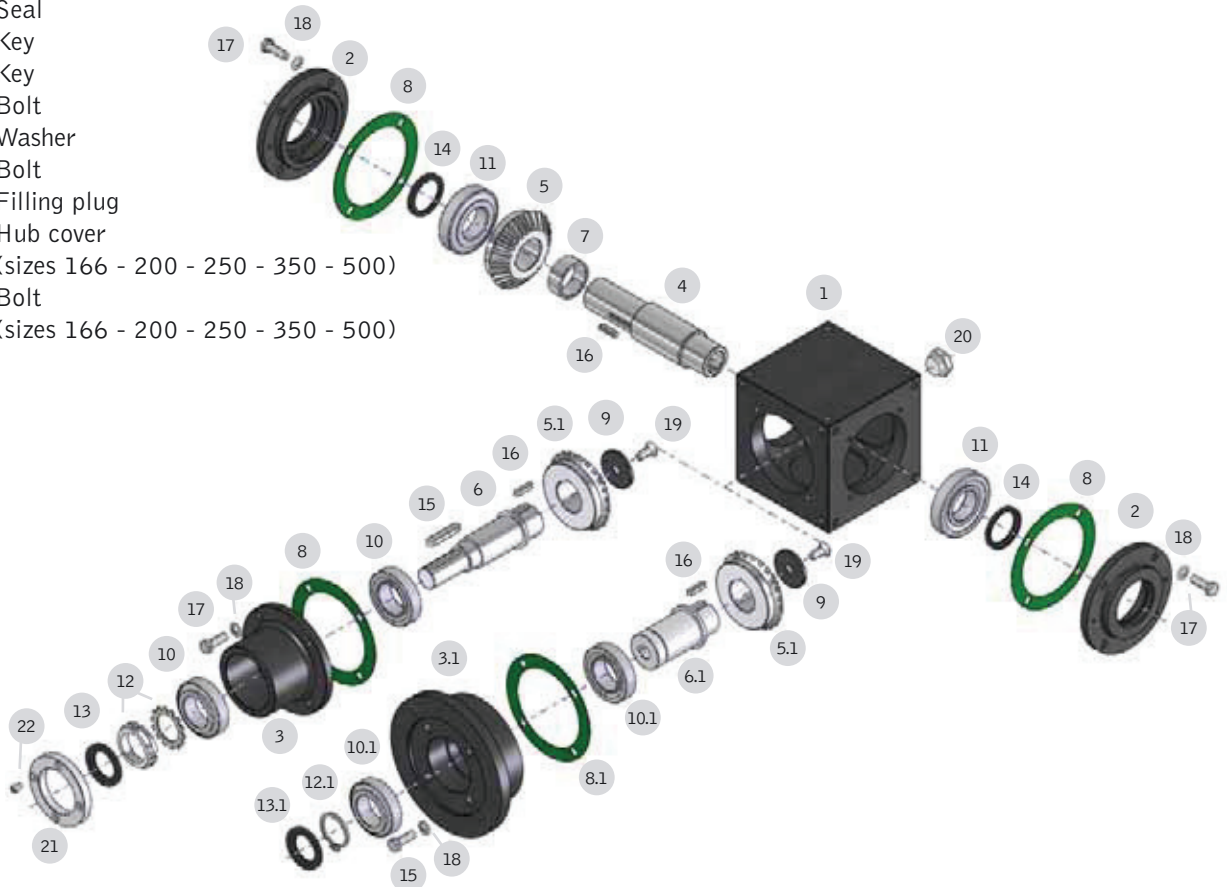

*For the RM model, gear and pinion are inverted



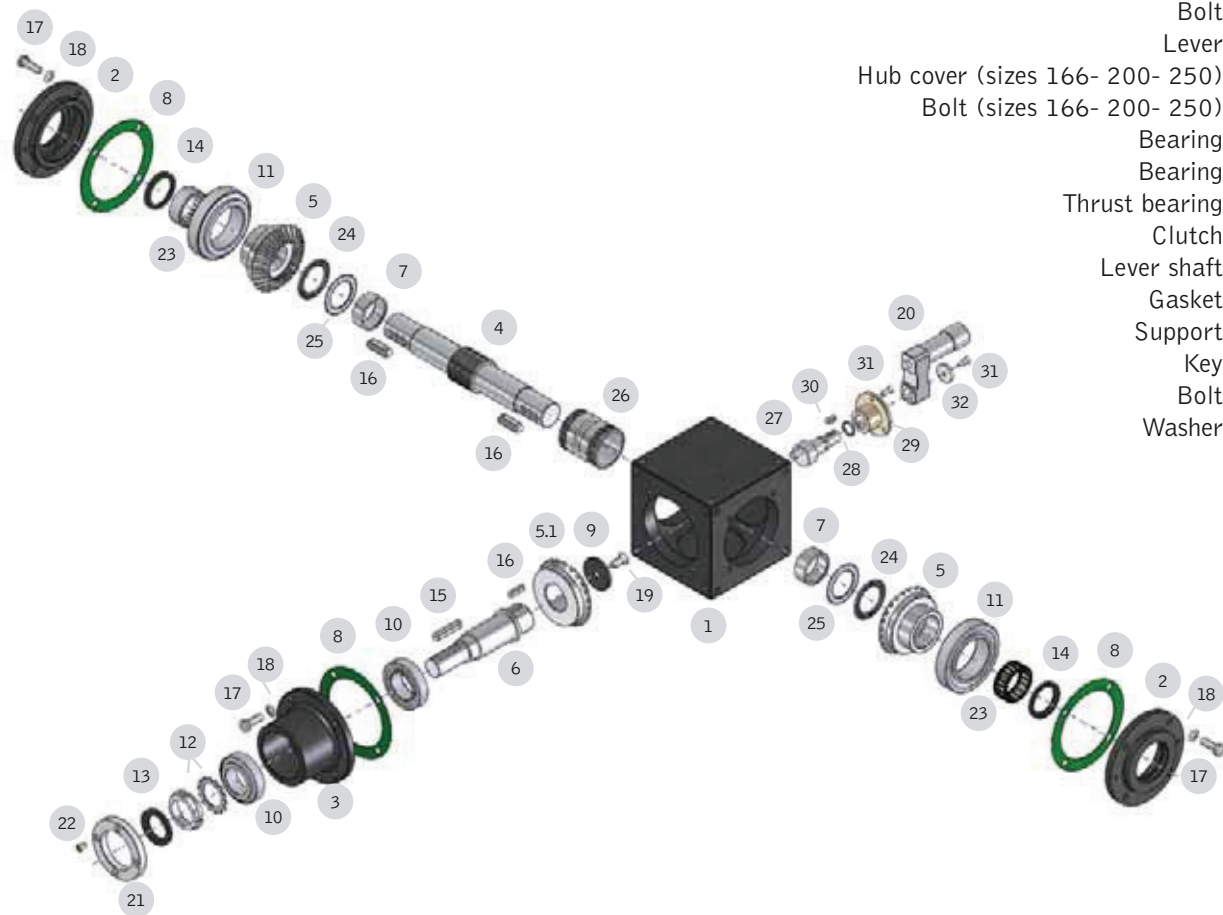

RIS Model

Casing	1
Cover	2
Hub	3
Protruding shaft	4
Bevel gear	5
Bevel pinion	5.1
Hub shaft	6
Spacer	7
Gasket	8
Lock washer	9
Bearing	10
Bearing	11
Stop ring	12
Seal	13
Seal	14
Key	15
Key	16
Bolt	17
Washer	18
Bolt	19
Lever	20
Hub cover (sizes 166- 200- 250)	21
Bolt (sizes 166- 200- 250)	22
Bearing	23
Bearing	24
Thrust bearing	25
Clutch	26
Lever shaft	27
Gasket	28
Support	29
Key	30
Bolt	31
Washer	32

Models: RE - MRE

- 1 Casing
- 2 Cover
- 3 Hub
- 3.1 Motor flange
- 4 Shaft (hollow-protruding-broached - with shrink disk)
- 5 Bevel gear
- 5.1 Bevel pinion
- 6 Hub shaft
- 6.1 Drive shaft
- 7 Spacer
- 8 Gasket
- 8.1 Gasket for motorisation
- 9 Lock washer
- 10 Bearing
- 10.1 Bearing for motorisation
- 11 Bearing
- 12 Stop ring
- 12.1 Stop ring for motorisation
- 13 Seal
- 13.1 Seal for motorisation
- 14 Seal
- 15 Key
- 16 Key
- 17 Bolt
- 18 Washer
- 19 Bolt
- 20 Filling plug
- 21 Snap ring
- 22 Bolt
- 23 Casing
- 24 Flange
- 25 Sun gear
- 26 Snap ring
- 27 Planet-holding shaft
- 28 Planet
- 29 Bearing
- 30 Shaft
- 31 Stop ring

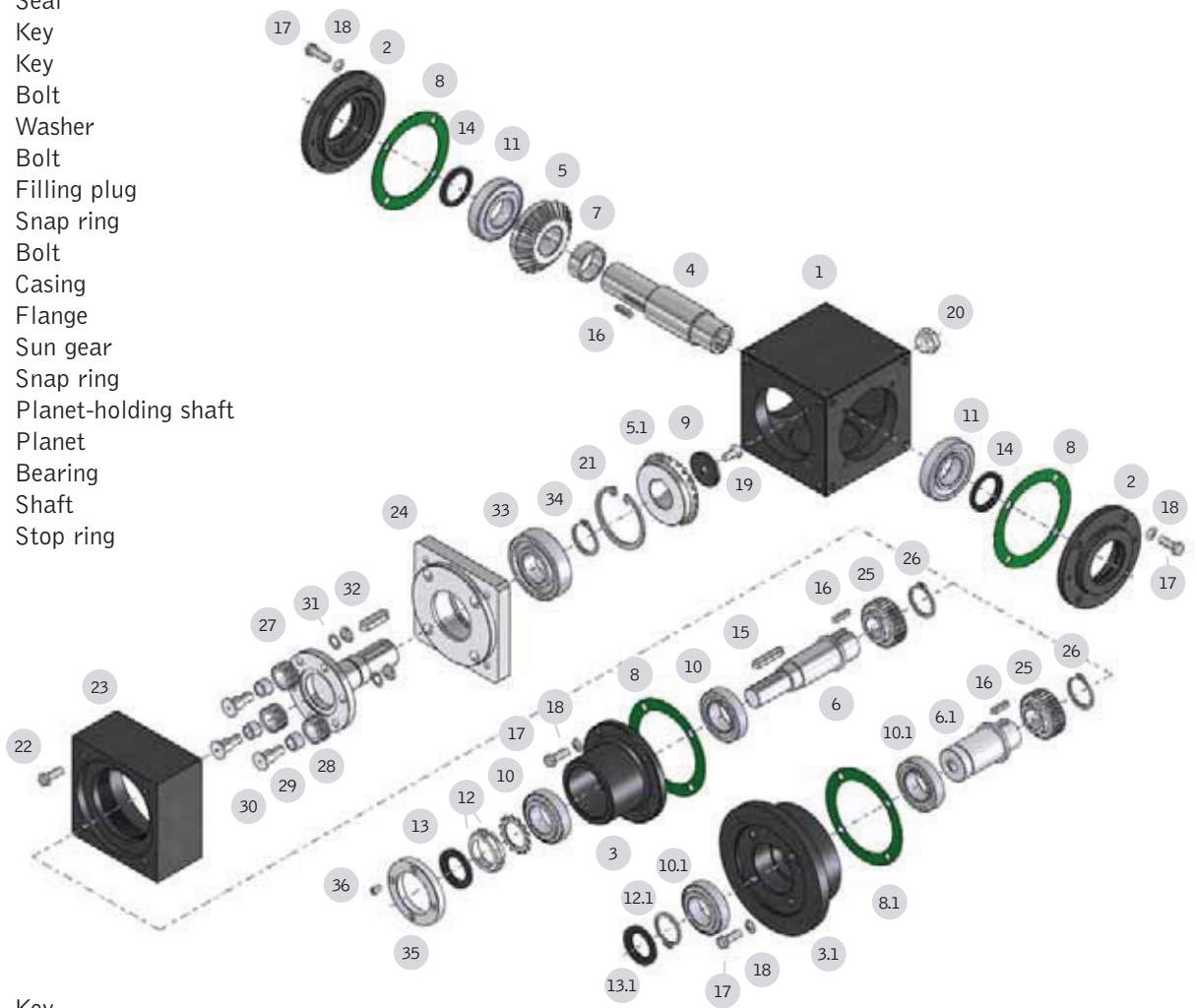

- 32 Key
- 33 Bearing
- 34 Stop ring
- 35 Cover (sizes 42 - 55)
- 36 Bolt (sizes 42 - 55)



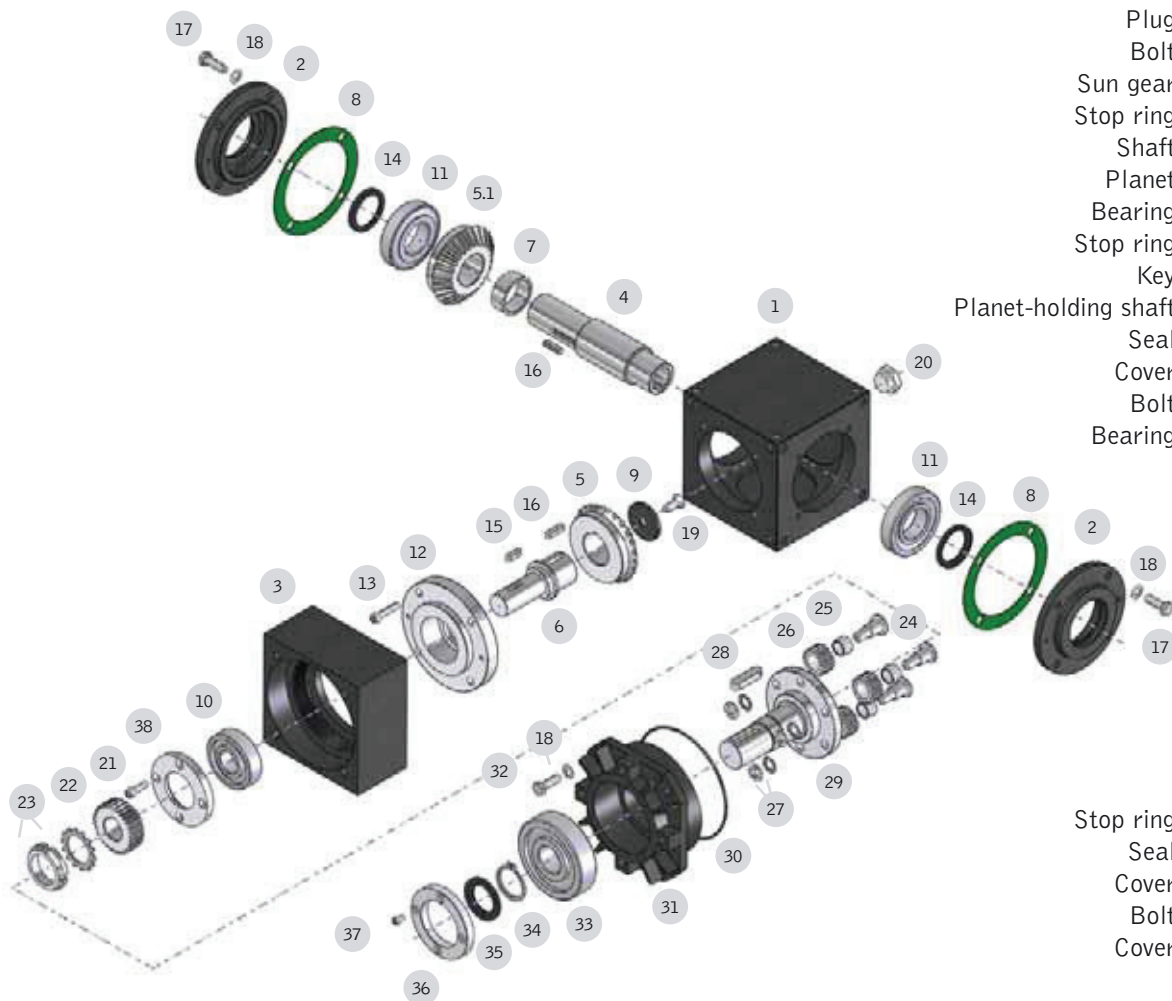

RH Model

Casing	1
Cover	2
Casing	3
Shaft (hollow –protruding- broached – with shrink disk)	4
Bevel gear	5
Bevel pinion	5.1
Shaft	6
Spacer	7
Gasket	8
Lock washer	9
Bearing	10
Bearing	11
Flange	12
Bolt	13
Seal	14
Key	15
Key	16
Bolt	17
Washer	18
Bolt	19
Plug	20
Bolt	21
Sun gear	22
Stop ring	23
Shaft	24
Planet	25
Bearing	26
Stop ring	27
Key	28
Planet-holding shaft	29
Seal	30
Cover	31
Bolt	32
Bearing	33
Stop ring	34
Seal	35
Cover	36
Bolt	37
Cover	38

DIMENSIONING OF THE BEVEL GEARBOX

For a correct dimensioning of bevel gearbox it is necessary to observe the following steps:

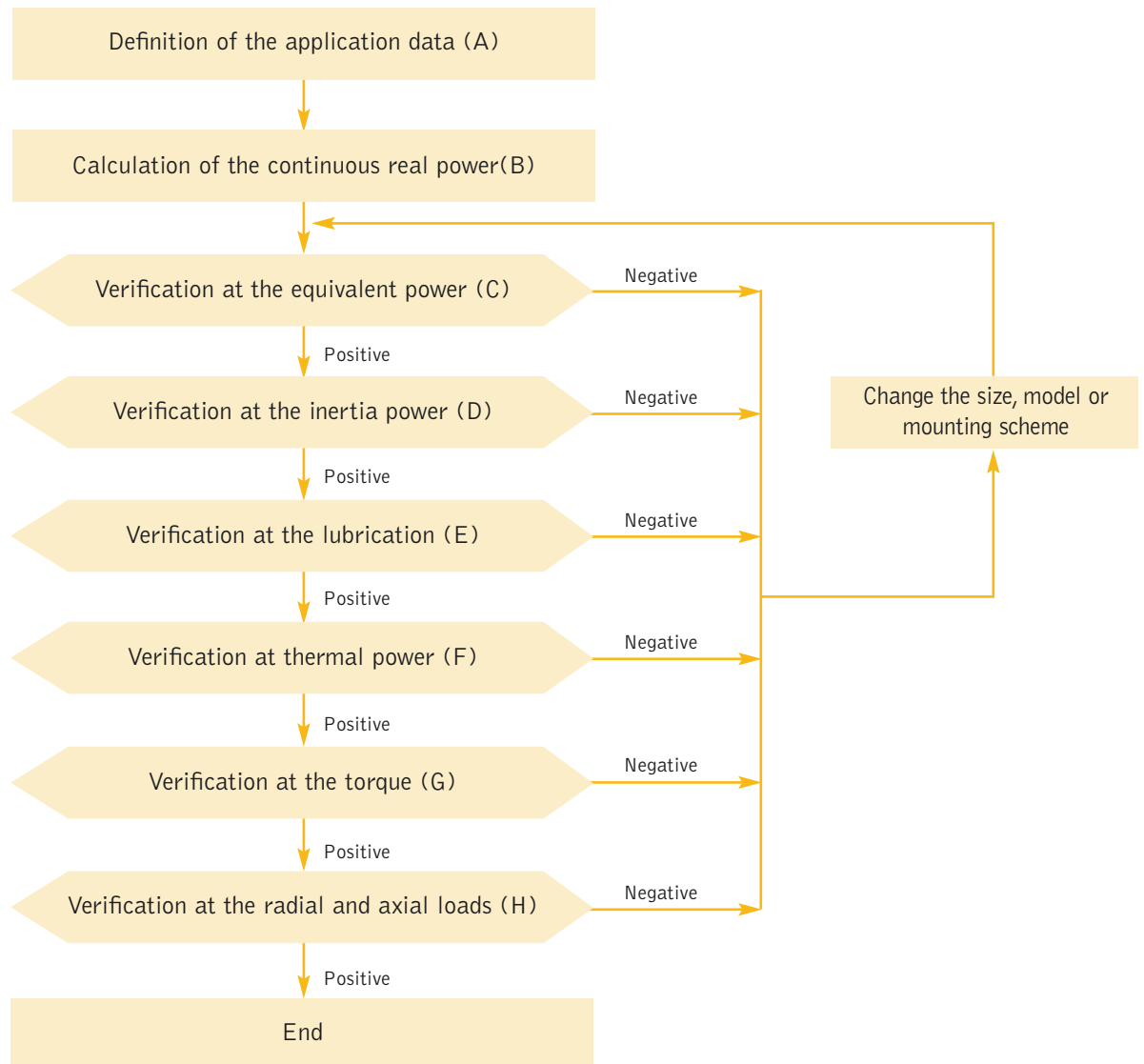

A – THE APPLICATION DATA

For a right dimensioning of the bevel gearboxes it is necessary to identify the application data: POWER, TORQUE, AND REVOLUTION SPEED = a P power [kW] is defined as the product between the torque M_t [daNm] and the revolution speed ω [rpm]. The input power (P_i) is equal to the sum of the output power (P_u) and the power dissipated into heat (P_d). The ratio of output power and input power is called running efficiency η of the transmission.

The slow shaft revolution speed ω_L is equal to the fast shaft revolution ω_v multiplied by the reduction ratio i (meant as a fraction). Some useful formulas that link the above variables are shown below

$$P_v = \frac{M_{tv} \cdot \omega_v}{955} \quad P_L = \frac{M_{tL} \cdot \omega_L}{955} \quad \omega_L = \omega_v \cdot i \quad P_i = P_u + P_d = \frac{P_u}{\eta}$$

AMBIENT VARIABLES = these values identify the environment and the operating conditions of the bevel gearbox. Among them: temperature, oxidizing and corrosive factors, working and non-working periods, vibrations, maintenance and cleaning, insertion frequency, expected lifetime etc.

MOUNTING SCHEMES = There are several ways of transferring movement by means of bevel gearboxes. A clear idea on the mounting scheme allows to correctly identify the power flow of the same.

B – THE REAL CONTINUOUS POWER

The first step for the dimensioning of a bevel gear box is to calculate the real continuous power. By means of the formulas indicated at point A the user must calculate the input power P_i according to the scheme parameters. Two calculation criteria can be adopted: using the average parameters calculated on a significant period or adopting the maximum parameters. It is obvious that the second method (the worst case) is much more protective with respect to the average one and it should be used in case you need certainty and reliability.

C – THE POWER TABLES AND THE EQUIVALENT POWER

All the values listed in the catalogue refer to a use in standard conditions, that is with a 20° temperature and under a regular running, without shocks for 8 daily working hours. The use under those conditions provides a lifetime of 10.000 hours. For different application conditions the equivalent power P_e should be calculated: it is the power which would be applied in standard conditions in order to have the same thermal exchange and wear effects, which the real load achieves in the real conditions of use. It is therefore advisable to calculate the equivalent load according to the following formula:

$$P_e = P_i \cdot f_g \cdot f_a \cdot f_d$$

It should be remarked that the equivalent power is not the power requested by the speed modulation gearbox: it is an indicator which helps in choosing the most suitable size in order to have higher reliability requisites. The power requested by the application is the input power P_i .

The usage factor f_g

The graph below can be used to calculate the usage factor f_g according to the working hours on a daily basis.

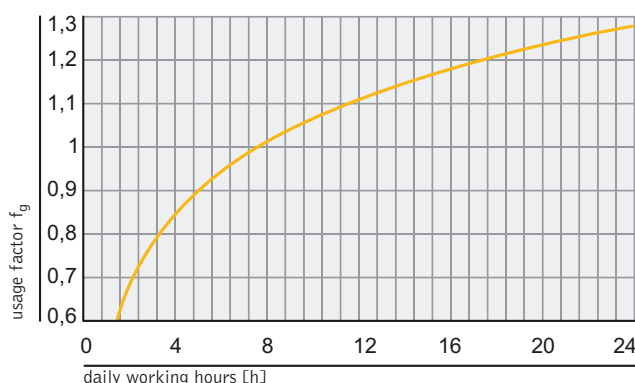

The ambient factor f_a

By means of the following table it is possible to calculate the f_a factor according to the operation conditions.

Type of load	daily working hours [h]:	3	8	24
Light shocks, few insertions, regular movements		0,8	1,0	1,2
Medium shocks, frequent insertions, regular movements		1,0	1,2	1,5
High shocks, many insertions, irregular movements		1,2	1,8	2,4

The duration factor f_d

The duration f_d is obtained according to the theoretical expected lifetime (expressed in hours).

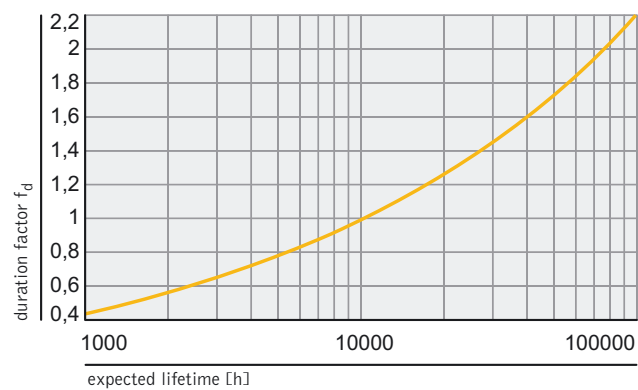

With the equivalent power value P_e and according to the angular speeds and reduction ratio, it is possible to choose, on the descriptive tables the size which presents an input power higher than the one calculated.



D – THE INERTIA POWER

In case of important accelerations and decelerations it is necessary to calculate the inertia power P_J . It is the power necessary to counteract the inertia forces and torques opposed by the system in case of speed changes. First of all it is necessary that the designer calculates the system inertia downstream of the bevel gearbox J_v first reducing them to the slow shaft and than to the fast one. After that the bevel gearbox inertia J_r must be added, which can be taken from the table below, valid for bevel gearboxes with double conical gear, than the total inertia J will be obtained. We remind that the inertia moments are expressed in $[\text{kg}\cdot\text{m}^2]$.

Size	Model		Ratio				
			1/1	1/1,5	1/2	1/3	1/4
54	RC RB RA	$[\text{kg}\cdot\text{m}^2]$	0,000133	0,000049	0,000026	0,000014	0,000010
	RS RX	$[\text{kg}\cdot\text{m}^2]$	0,000134	0,000050	0,000027	0,000016	0,000011
86	RC RR RB RA	$[\text{kg}\cdot\text{m}^2]$	0,000334	0,000122	0,000066	0,000034	0,000024
	RS RP RX RZ RM	$[\text{kg}\cdot\text{m}^2]$	0,000366	0,000136	0,000074	0,000037	0,000026
110	RC RR RB RA	$[\text{kg}\cdot\text{m}^2]$	0,000733	0,000270	0,000151	0,000081	0,000059
	RS RP RX RZ RM	$[\text{kg}\cdot\text{m}^2]$	0,000798	0,000299	0,000168	0,000089	0,000063
134	RC RR RB RA	$[\text{kg}\cdot\text{m}^2]$	0,002440	0,000887	0,000497	0,000267	0,000197
	RS RP RX RZ RM	$[\text{kg}\cdot\text{m}^2]$	0,002593	0,000955	0,000535	0,000284	0,000207
166	RC RR RB RA	$[\text{kg}\cdot\text{m}^2]$	0,010363	0,003609	0,001928	0,000924	0,000618
	RS RP RX RZ RM	$[\text{kg}\cdot\text{m}^2]$	0,011171	0,003968	0,002130	0,001013	0,000669
200	RC RR RB RA	$[\text{kg}\cdot\text{m}^2]$	0,024061	0,009037	0,004728	0,002325	0,001576
	RS RP RX RZ RM	$[\text{kg}\cdot\text{m}^2]$	0,026254	0,010012	0,005276	0,002669	0,001713
250	RC RR RB RA	$[\text{kg}\cdot\text{m}^2]$	0,083743	0,029423	0,015813	0,007811	0,005348
	RS RP RX RZ RM	$[\text{kg}\cdot\text{m}^2]$	0,091467	0,032856	0,017744	0,008669	0,005831
350	RC RR RB RA	$[\text{kg}\cdot\text{m}^2]$	0,740939	0,255341	0,135607	0,060030	0,034340
	RS RP RX RZ RM	$[\text{kg}\cdot\text{m}^2]$	0,755302	0,261725	0,139198	0,061626	0,035238
500	RC RR RB RA	$[\text{kg}\cdot\text{m}^2]$	1,704159	0,587284	0,311896	0,138069	0,078982
	RS RP RX RZ RM	$[\text{kg}\cdot\text{m}^2]$	1,737194	0,601967	0,320155	0,141739	0,081047

Size	Model		Ratio					
			1/2	1/3	1/4,5	1/6	1/9	1/12
32	REC REB	$[\text{kg}\cdot\text{m}^2]$	-	-	0,003457	0,003067	0,002837	0,002767
	REA RES	$[\text{kg}\cdot\text{m}^2]$	-	-	0,003525	0,003105	0,002854	0,002777
	RHC RHB RHA	$[\text{kg}\cdot\text{m}^2]$	0,006230	0,005010	-	-	-	-
	RHS	$[\text{kg}\cdot\text{m}^2]$	0,006459	0,005163	0,003525	-	-	-
42	REC REB	$[\text{kg}\cdot\text{m}^2]$	-	-	0,014292	0,012611	0,011607	0,011301
	REA RES	$[\text{kg}\cdot\text{m}^2]$	-	-	0,014651	0,012813	0,011696	0,011352
	RHC RHB RHA	$[\text{kg}\cdot\text{m}^2]$	0,26227	0,021046	-	-	-	-
	RHS	$[\text{kg}\cdot\text{m}^2]$	0,027439	0,021854	0,014651	-	-	-
55	REC REB	$[\text{kg}\cdot\text{m}^2]$	-	-	0,029678	0,025369	0,022966	0,022217
	REA RES	$[\text{kg}\cdot\text{m}^2]$	-	-	0,030653	0,025917	0,023310	0,022354
	RHC RHB RHA	$[\text{kg}\cdot\text{m}^2]$	0,056732	0,044702	-	-	-	-
	RHS	$[\text{kg}\cdot\text{m}^2]$	0,060022	0,046895	0,030653	-	-	-

Given ω_v the fast revolution speed and α_v the angular acceleration of the fast shaft, the inertia torque which is necessary to counteract is equal to $J \cdot \alpha_v$ and the respective inertia power P_j is equal to $J \cdot \omega_v \cdot \alpha_v$. In case the time curve of the fast shaft speed ω_v can be traced back to one of the four schemes below, linear or sinusoidal, where A is the maximum speed in [rpm] and B is the cycle frequency in [Hz], the calculation of the inertia power in [kW] can be simplified, by taking A and B parameters and by calculating:

$$P_j = \frac{2 \cdot J \cdot A^2 \cdot B}{91188}$$

The power P_j must be added to the equivalent power P_e and a verification of the correctness of the size chosen on the descriptive tables must be carried out. If not correct it will be necessary to change the size and effect new verifications.

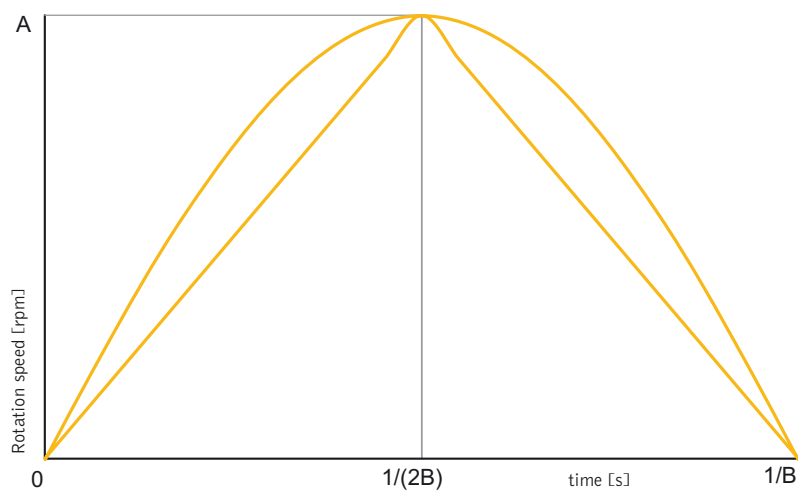
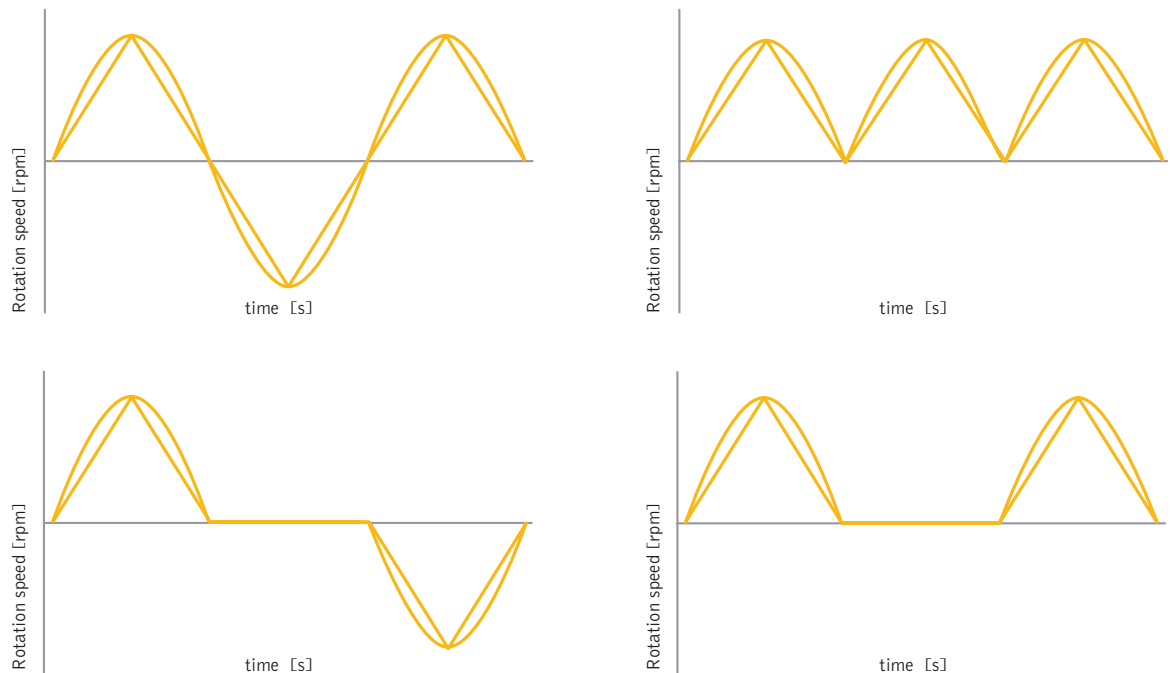

E – LUBRICATION

After a first dimensioning according to the power, it is advisable to check whether the only splash lubrication is enough or if a forced lubrication system is necessary. It should be therefore checked, by means of the graph illustrated in the "lubrication" paragraph, whether the average speed of the fast shaft is above or below the border value. In case of speed reaching the border value it will be necessary to contact our technical office. If, in a status of forced lubrication, it is possible to carry out the mounting, it is advisable to calculate the requested lubricant flow-rate Q [l/min.], being known the input power P_i [kW], the running efficiency η , the lubricant specific heat c_p [J/(kg•°C)], the ambient temperature t_a and the maximum temperature which can be reached by the bevel gearbox t_r [°C].

$$Q = \frac{67000 \cdot (1 - \eta) \cdot P_i}{c_p \cdot (t_r - t_a)}$$

In case it is not possible to provide a forced lubrication system it is necessary to change the size.

F – THE THERMAL POWER

When on the descriptive tables the input power values fall into the coloured area, this means that it is necessary to check the thermal power. This dimension, a function of the bevel gearbox size and of the ambient temperature, indicates the input power establishing a thermal balance with the ambient at the bevel gearbox surface temperature of 90°C. The following graphs show the waves of the thermal power in case of two or three gears transmission.

TWO GEARS TRANSMISSION

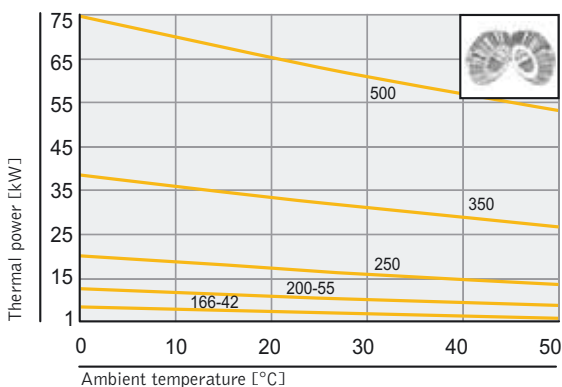
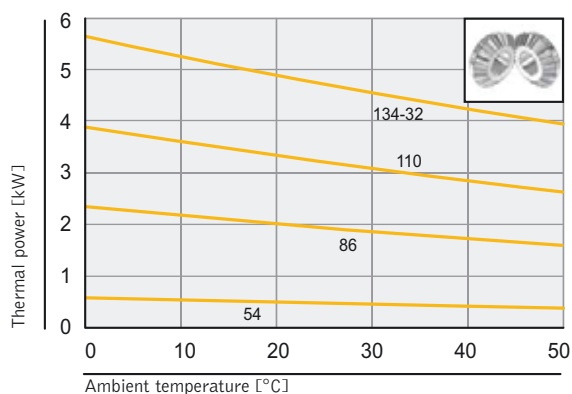

THREE GEARS TRANSMISSION

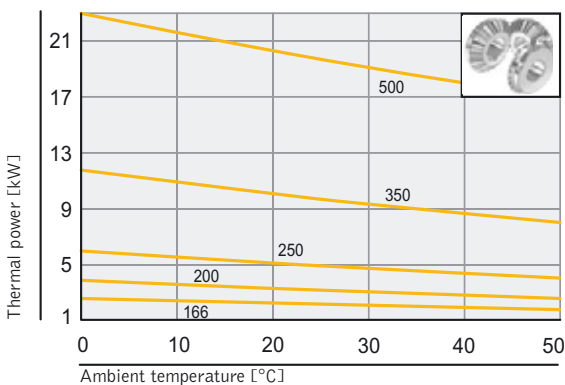
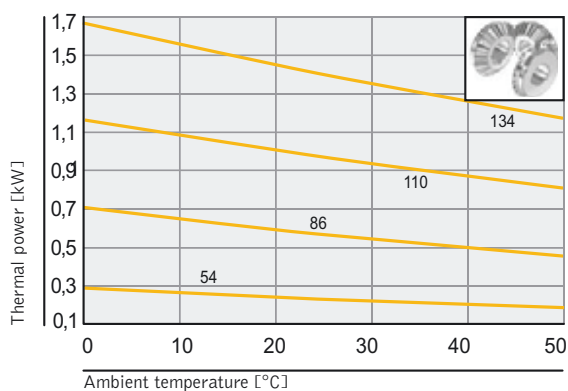

In case there are non-working times in the bevel gearbox operation, the thermal power can be increased of a factor PTC obtainable from the graph below, where the abscissas is the use percentage as referred to the hour.

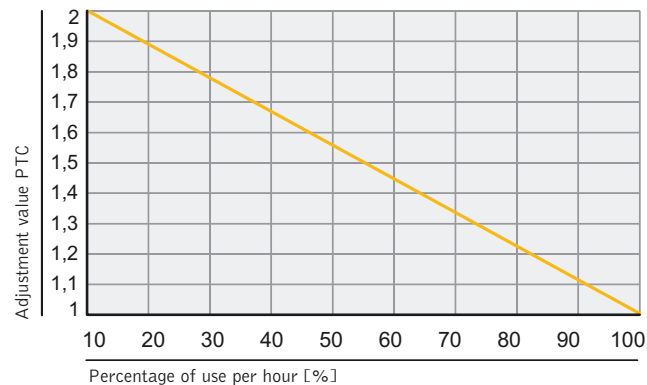

In case the thermal power is lower that the requested power P_i , it will be necessary to change the bevel gearbox size or to pass to forced lubrication. For the capacity calculation see paragraph E.

G - THE TORQUE

When one or more bevel gearboxes are mounted in series, it is necessary to check that the torque referred to the common axis does not exceed the value shown in the table below.

Model	Size	54	86	110	134	166	200	250	350	500	32	42	55
RC RA RB	[daNm]	4	9	18	32	77	174	391	1205	5392	-	-	-
RR RM RIS													
RS RP	[daNm]	13	32	41	77	214	391	807	1446	5387	-	-	-
RHA RHB RHC	[daNm]	-	-	-	-	-	-	-	-	-	32	77	174
RHS (1/2 1/3)	[daNm]	-	-	-	-	-	-	-	-	-	77	214	391
RHS (1/4,5)	[daNm]	-	-	-	-	-	-	-	-	-	32	77	174



H- RADIAL AND AXIAL LOADS

The last step is to verify the bevel gearbox strength to radial and axial loads. The border values of said loads are shown on pages 172-175. If the result of such verification is not positive, it will be necessary to change the size.



RC RR RB RA RS RP RX RZ RIS

		Ratio 1/1																	
		54		86		110		134		166		200		250		350		500	
Fast shaft revolution speed ω_v [rpm]	Fast shaft revolution speed ω_L [rpm]	P _i	M _{tL}	P _i	M _{tL}	P _i	M _{tL}	P _i	M _{tL}	P _i	M _{tL}	P _i	M _{tL}	P _i	M _{tL}	P _i	M _{tL}	P _i	M _{tL}
		[kW]	[daNm]	[kW]	[daNm]	[kW]	[daNm]	[kW]	[daNm]	[kW]	[daNm]	[kW]	[daNm]	[kW]	[daNm]	[kW]	[daNm]	[kW]	[daNm]
3000	3000	4,14	1,26	19,4	5,92	29,4	8,98	53,6	16,2	148	44,7	256	76,6	453	135	1184	354	-	-
1500	1500	2,20	1,34	10,4	6,35	15,7	9,59	28,7	17,3	80,3	48,5	140	83,7	249	149	660	394	1650	945
1000	1000	1,80	1,65	7,57	6,94	10,9	9,99	20,0	18,1	56,3	51,0	98,5	88,4	176	158	469	421	1266	1088
750	750	1,45	1,77	6,12	7,48	8,84	10,8	16,2	19,5	45,8	55,4	80,3	96,1	143	171	385	460	1044	1196
500	500	1,07	1,96	4,51	8,26	6,53	11,9	12,0	21,7	34,0	61,6	59,8	107	107	192	290	520	790	1358
250	250	0,62	2,27	2,66	9,75	3,86	14,1	7,15	25,9	20,3	73,6	35,8	128	64,6	231	176	631	483	1660
100	100	0,30	2,75	1,31	12,0	1,90	17,4	3,54	32,1	10,1	91,6	17,9	160	32,4	290	89,0	798	246	2114
50	50	0,18	3,30	0,76	13,9	1,11	20,3	2,06	37,3	5,91	107	10,4	186	19,0	341	52,5	942	146	2510

RC RR RB RA RS RP RM RX RZ

		Ratio 1/1,5																	
		54		86		110		134		166		200		250		350		500	
Fast shaft revolution speed ω_v [rpm]	Fast shaft revolution speed ω_L [rpm]	P _i	M _{tL}	P _i	M _{tL}	P _i	M _{tL}	P _i	M _{tL}	P _i	M _{tL}	P _i	M _{tL}	P _i	M _{tL}	P _i	M _{tL}	P _i	M _{tL}
		[kW]	[daNm]	[kW]	[daNm]	[kW]	[daNm]	[kW]	[daNm]	[kW]	[daNm]	[kW]	[daNm]	[kW]	[daNm]	[kW]	[daNm]	[kW]	[daNm]
3000	2000	2,46	1,12	10,3	4,72	13,0	5,95	28,5	12,9	88,1	39,9	159	71,3	238	106	610	273	-	-
1500	1000	1,28	1,17	5,54	5,07	6,96	6,38	15,3	13,8	47,2	42,8	85,7	76,9	129	115	335	300	907	779
1000	667	0,88	1,21	4,15	5,70	4,91	6,75	10,8	14,6	32,9	44,7	60,0	80,7	90,7	122	237	319	690	890
750	500	0,71	1,30	3,30	6,05	3,96	7,26	8,78	15,9	26,7	48,4	48,7	87,4	73,8	132	193	346	566	973
500	333	0,52	1,43	2,30	6,32	2,91	8,00	6,48	17,6	19,7	53,6	36,2	97,4	54,9	147	145	390	425	1096
250	167	0,30	1,65	1,41	7,75	1,71	9,40	3,82	20,7	11,7	63,6	21,5	115	32,7	176	87,1	469	258	1330
100	66,7	0,15	2,06	0,65	8,93	0,84	11,5	1,88	25,5	5,80	78,9	10,6	142	16,3	219	43,7	588	130	1675
50	33,3	0,08	2,20	0,38	10,4	0,49	13,4	1,09	29,6	3,38	91,9	6,24	168	9,54	256	25,6	689	76,8	1980

RC RR RB RA RS RP RX RZ RIS

		Ratio 1/2																	
		54		86		110		134		166		200		250		350		500	
Fast shaft revolution speed ω_v [rpm]	Fast shaft revolution speed ω_L [rpm]	P _i	M _{tL}	P _i	M _{tL}	P _i	M _{tL}	P _i	M _{tL}	P _i	M _{tL}	P _i	M _{tL}	P _i	M _{tL}	P _i	M _{tL}	P _i	M _{tL}
		[kW]	[daNm]	[kW]	[daNm]	[kW]	[daNm]	[kW]	[daNm]	[kW]	[daNm]	[kW]	[daNm]	[kW]	[daNm]	[kW]	[daNm]	[kW]	[daNm]
3000	1500	1,53	0,93	6,04	3,69	8,20	5,01	20,7	12,5	43,8	26,4	91,2	54,5	170	101	538	321	-	-
1500	750	0,80	0,97	3,20	3,91	4,35	5,31	11,0	13,3	23,5	28,4	49,3	59,0	91,5	109	293	350	588	674
1000	500	0,57	1,04	2,41	4,41	3,32	6,08	8,87	16,0	18,9	34,2	34,8	62,4	63,9	114	206	369	457	785
750	375	0,45	1,10	1,94	4,74	2,67	6,52	7,15	17,2	15,3	37,0	28,2	67,5	51,9	124	168	402	373	855
500	250	0,34	1,24	1,42	5,20	1,96	7,18	5,27	19,1	11,3	41,0	20,8	74,6	38,5	138	125	448	279	960
250	125	0,20	1,46	0,83	6,08	1,15	8,43	3,10	22,5	6,67	48,4	12,3	88,3	22,9	164	75,0	538	168	1155
100	50	0,09	1,65	0,41	7,51	0,57	10,4	1,52	27,5	3,28	59,5	6,09	109	11,4	204	37,4	671	84,6	1454
50	25	0,05	1,83	0,24	8,80	0,33	12,1	0,89	32,2	1,91	69,3	3,55	127	6,61	237	21,9	786	49,7	1710

In case the bevel gearbox is used as multiplier, and for RM models, in order to obtain the output torque value (as referred to the fast shaft) it is necessary to multiply the value on the table by the reduction ratio (meant as a fraction).

RHC RHB RHA RHS

		Ratio 1/2					
		32		42		55	
Fast shaft revolution speed ω_v [rpm]	Fast shaft revolution speed ω_L [rpm]	P_i [kW]	M_{tL} [daNm]	P_i [kW]	M_{tL} [daNm]	P_i [kW]	M_{tL} [daNm]
2000	1000	11,7	10,0	31,1	26,7	46,0	39,5
1500	750	10,0	11,4	24,2	27,7	36,2	41,4
1000	500	7,15	12,3	18,0	30,9	26,5	45,5
700	350	5,54	13,6	13,5	33,2	19,6	48,1
500	250	4,35	14,9	10,0	34,4	15,2	52,2
300	150	3,02	17,3	7,40	42,4	10,2	58,4
100	50	1,37	23,5	2,78	47,8	4,04	69,4
50	25	0,74	25,4	1,52	52,2	2,26	77,6

RC RR RB RA RS RP RX RZ

		Ratio 1/3																	
		54		86		110		134		166		200		250		350		500	
Fast shaft revolution speed ω_v [rpm]	Fast shaft revolution speed ω_L [rpm]	P_i [kW]	M_{tL} [daNm]	P_i [kW]	M_{tL} [daNm]	P_i [kW]	M_{tL} [daNm]	P_i [kW]	M_{tL} [daNm]	P_i [kW]	M_{tL} [daNm]	P_i [kW]	M_{tL} [daNm]	P_i [kW]	M_{tL} [daNm]	P_i [kW]	M_{tL} [daNm]	P_i [kW]	M_{tL} [daNm]
3000	1000	0,74	0,67	2,79	2,55	4,09	3,74	9,19	8,33	24,7	22,4	50,1	44,9	76,5	68,9	289	259	-	-
1500	500	0,39	0,71	1,47	2,96	2,15	3,94	4,86	8,81	13,1	23,7	26,8	48,1	41,3	74,1	155	278	300	515
1000	333	0,32	0,88	1,30	3,57	1,57	4,31	4,27	11,6	10,2	27,7	22,4	60,3	34,5	92,9	108	290	225	578
750	250	0,25	0,91	1,14	4,18	1,26	4,62	3,50	12,7	8,27	30,0	18,1	64,9	28,0	100	88,4	317	183	630
500	166	0,19	1,04	0,82	4,51	0,93	5,11	2,56	13,9	6,09	33,1	13,3	71,6	20,6	110	65,5	352	136	700
250	83	0,11	1,21	0,46	5,06	0,54	5,94	1,50	16,3	3,58	38,9	7,86	84,6	12,2	131	39,0	420	81,0	835
100	33	0,06	1,37	0,21	5,77	0,26	7,15	0,74	20,1	1,75	47,6	3,87	104	6,01	161	19,3	519	40,5	1044
50	16,7	0,03	1,65	0,12	6,60	0,15	8,25	0,42	22,8	1,02	55,5	2,24	120	3,50	188	11,2	603	23,8	1227

RHC RHB RHA RHS

		Ratio 1/3					
		32		42		55	
Fast shaft revolution speed ω_v [rpm]	Fast shaft revolution speed ω_L [rpm]	P_i [kW]	M_{tL} [daNm]	P_i [kW]	M_{tL} [daNm]	P_i [kW]	M_{tL} [daNm]
3000	1000	13,3	11,4	-	-	-	-
2000	667	9,69	12,4	22,4	28,8	32,9	42,3
1500	500	7,72	13,2	18,0	30,9	26,5	45,6
1000	333	5,81	14,9	13,5	34,8	20,0	51,6
700	233	4,21	15,5	9,82	36,2	14,4	53,1
500	166	3,26	16,7	7,63	39,2	11,1	57,1
300	100	2,27	19,5	5,17	44,4	7,50	64,4
100	33	0,95	24,5	1,94	50,0	3,01	77,7
50	16,7	0,54	27,8	1,05	54,0	1,61	82,5



RC RR RB RA RS RP RX RZ

		Ratio 1/4																	
		54		86		110		134		166		200		250		350		500	
Fast shaft revolution speed ω_v [rpm]	Fast shaft revolution speed ω_L [rpm]	P_i [kW]	M_{tL} [daNm]	P_i [kW]	M_{tL} [daNm]	P_i [kW]	M_{tL} [daNm]	P_i [kW]	M_{tL} [daNm]	P_i [kW]	M_{tL} [daNm]	P_i [kW]	M_{tL} [daNm]	P_i [kW]	M_{tL} [daNm]	P_i [kW]	M_{tL} [daNm]	P_i [kW]	M_{tL} [daNm]
3000	750	0,45	0,55	1,89	2,31	2,73	3,33	6,37	7,70	12,2	14,7	30,8	36,8	45,3	54,2	189	226	-	-
1500	375	0,24	0,58	1,00	2,44	1,43	3,49	3,36	8,12	6,49	15,7	16,4	39,2	24,2	57,9	100	239	155	355
1000	250	0,21	0,77	0,89	3,26	1,22	4,47	2,86	10,3	5,54	20,1	13,0	46,6	20,8	74,6	70,2	252	144	496
750	188	0,19	0,92	0,73	3,56	0,98	4,79	2,30	11,1	4,46	21,5	10,5	50,2	16,7	79,9	56,8	271	117	536
500	125	0,14	1,02	0,54	3,96	0,71	5,20	1,68	12,1	3,27	23,7	7,73	55,5	12,3	88,3	42,0	301	87,0	600
250	62,5	0,08	1,17	0,31	4,54	0,42	6,16	0,98	14,2	1,92	27,8	4,53	65,0	7,26	104	24,9	357	51,7	711
100	25	0,04	1,46	0,15	5,50	0,20	7,33	0,48	17,4	0,94	34,1	2,22	79,7	3,57	128	12,3	441	25,6	880
50	12,5	0,02	1,68	0,09	6,60	0,12	8,80	0,28	20,3	0,55	39,9	1,30	93,3	2,08	149	7,16	514	14,9	1024

RHS

		Ratio 1/4,5					
		32		42		55	
Fast shaft revolution speed ω_v [rpm]	Fast shaft revolution speed ω_L [rpm]	P_i [kW]	M_{tL} [daNm]	P_i [kW]	M_{tL} [daNm]	P_i [kW]	M_{tL} [daNm]
3000	667	9,69	12,4	22,4	28,8	-	-
2000	444	7,07	13,6	16,5	31,9	24,2	46,8
1500	333	5,81	14,9	13,5	34,8	20,0	51,6
1000	222	4,02	15,5	9,70	37,5	13,9	53,8
700	156	3,10	17,1	7,29	40,1	10,4	57,3
500	111	2,35	18,2	5,54	42,9	8,05	62,3
300	66,7	1,65	21,3	3,57	46,0	5,21	67,1
100	22,2	0,65	25,1	1,34	51,8	2,37	91,7
50	11,1	0,44	34,0	0,84	65,0	1,31	101

REC REB REA RES

		Ratio 1/4,5					
		32		42		55	
Fast shaft revolution speed ω_v [rpm]	Fast shaft revolution speed ω_L [rpm]	P_i [kW]	M_{tL} [daNm]	P_i [kW]	M_{tL} [daNm]	P_i [kW]	M_{tL} [daNm]
3000	667	11,3	14,5	29,6	38,1	43,7	56,3
2000	444	8,46	16,3	21,3	41,1	31,3	60,5
1500	333	6,82	17,5	17,1	44,0	25,2	64,9
1000	222	5,00	19,3	12,9	49,8	19,2	73,4
700	156	3,81	21,0	9,30	51,3	13,7	75,6
500	111	2,94	22,6	7,20	55,6	10,6	82,0
300	66,7	1,97	25,3	4,90	63,1	7,12	91,5
100	22,2	0,83	32,1	1,90	73,4	2,81	108
50	11,1	0,42	32,4	1,00	77,3	1,52	116

REC REB REA RES

		Ratio 1/6					
		32		42		55	
Fast shaft revolution speed ω_v [rpm]	Fast shaft revolution speed ω_L [rpm]	P_i [kW]	M_{tL} [daNm]	P_i [kW]	M_{tL} [daNm]	P_i [kW]	M_{tL} [daNm]
3000	500	9,33	16,0	19,8	34,0	36,6	62,9
2000	333	6,88	17,7	14,7	37,8	27,1	69,8
1500	250	5,54	19,0	11,8	40,5	21,8	74,9
1000	167	4,06	20,9	8,73	45,0	16,1	83,1
700	117	3,08	22,7	6,64	48,9	12,2	90,0
500	83,3	2,37	24,3	5,13	52,8	9,52	97,9
300	50	1,60	27,5	3,45	59,3	6,41	110
100	16,7	0,64	33,0	1,38	71,2	2,56	132
50	8,33	0,34	34,8	0,73	75,1	1,36	139

REC REB REA RES

		Ratio 1/9					
		32		42		55	
Fast shaft revolution speed ω_v [rpm]	Fast shaft revolution speed ω_L [rpm]	P_i [kW]	M_{tL} [daNm]	P_i [kW]	M_{tL} [daNm]	P_i [kW]	M_{tL} [daNm]
3000	333	4,49	11,5	10,7	27,5	23,5	60,5
2000	222	3,36	12,9	7,96	30,7	17,3	66,8
1500	167	2,69	13,8	6,41	33,0	14,0	72,1
1000	111	1,96	15,1	4,69	36,3	10,3	79,7
700	77,8	1,49	16,4	3,56	39,3	7,83	86,6
500	55,6	1,14	17,6	2,74	42,3	6,05	93,4
300	33,3	0,77	19,8	1,84	47,4	4,07	104
100	11,1	0,30	23,2	0,75	58,0	1,62	125
50	5,56	0,16	24,7	0,39	60,2	0,86	132

REC REB REA RES

		Ratio 1/12					
		32		42		55	
Fast shaft revolution speed ω_v [rpm]	Fast shaft revolution speed ω_L [rpm]	P_i [kW]	M_{tL} [daNm]	P_i [kW]	M_{tL} [daNm]	P_i [kW]	M_{tL} [daNm]
3000	250	3,01	10,3	5,83	20,0	13,6	46,7
2000	167	2,21	11,3	4,28	22,0	10,1	52,0
1500	125	1,76	12,1	3,44	23,6	8,13	55,9
1000	83,3	1,29	13,3	2,51	25,9	5,94	61,3
700	58,3	0,97	14,3	1,90	28,0	4,51	66,5
500	41,7	0,75	15,4	1,46	30,0	3,48	71,6
300	25	0,50	17,1	0,98	33,6	2,33	80,1
100	8,33	0,21	21,6	0,38	39,2	0,93	96,0
50	4,17	0,11	22,6	0,20	41,1	0,49	100



NIPLOY treatment

For applications in oxidizing environments, it is possible to protect some bevel gearbox components which do not undergo any sliding, by means of a chemical nickel treatment, the so-called Niploy. It creates a non permanent surface coating on casings and covers.

The stainless steel series

For applications where a permanent resistance to oxidizing is necessary, it is possible to supply the components in stainless steel. Sizes **86, 110 and 134** foresee a model in AISI 316, as a standard production, for all components: shafts, covers, bolts, casings, and motor flanges; the stainless steel series can be applied in the sea environment without any oxidizing problems. It is possible to supply all the remaining dimensions in AISI 304 or 316 steel as special components. For further information see pages 226-229.

NORMS

ATEX directive (94/9/CE)

The 94/9/CE directive is better known as the "ATEX directive". All UNIMEC's products may be classified as "components" according to the definition quoted in art.1 par.3 c), and therefore they do not require an ATEX mark.

A conformity declaration in accordance to what stated in art.8 par.3 can be supplied upon end user's request, subject to the filling up of a questionnaire with the indication of the working parameters.

Machinery directive (98/37/CE)

The 98/37/CE directive is better known as the "Machinery directive". UNIMEC's components are included in the products categories which do not need to affix the CE mark, as they are "intended to be incorporated or assembled with other machinery" (art.4 par.2). Upon end user's request a manufacturer declaration can be supplied in accordance to what is foreseen at Annex II, point B. The new machine directory (06/42/CE) will be acknowledged by 29/12/2009. UNIMEC guarantees that every new duty in mechanical transmission will be followed by such date.

ROHS directive (02/95/CE)

The 02/95/CE directive is better known as the "ROHS directive". All UNIMEC's suppliers of electromechanical equipments have issued a conformity certification to the above norms for their products. A copy of said certificates can be supplied upon final user's request.

REACH directive (06/121/CE)

The 06/121/CE is better known as "REACH" directive and applies as the rule CE 1907/2006. UNIMEC products present only inside lubricants as "substances", so being disciplined by art. 7 of above mentioned rule. By art. 7 par. 1 b) UNIMEC declares that its products are not subjected to any declaration or registration because the substances in them are not "to be lost in normal and reasonable previewed usage conditions"; in facts lubricant losses are typical of malfunctions or heavy anomalies. By art. 33 of the rule CE 1907/2006, UNIMEC declares that inside its products there aren't substances identified by art. 57 in percentage to be dangerous.

UNI EN ISO 9001:2000 norm

UNIMEC has always considered the company's quality system management as a very important subject. That is why, since the year 1996, UNIMEC is able to show its UNI EN ISO 9001 certification, at the beginning in accordance to the 1994 norms and now meeting the requirements of the version published in the year 2000. 13 years of company's quality, certified by UKAS, the world's most accredited certification body, take shape into an organization which is efficient at each stage of the working process. In date 31/10/2008 the new version of this norm was published. UNIMEC will evaluate every news reported in this revision.



Painting

Our products are all painted in color RAL 5015 blue. An oven-dry system enables the products to have a perfect adhesivity. Different colors as well as epoxidic paints are available.

Basic constructive forms

ratio:
1/1



ratio:
1/1,5 - 1/2 - 1/3 - 1/4

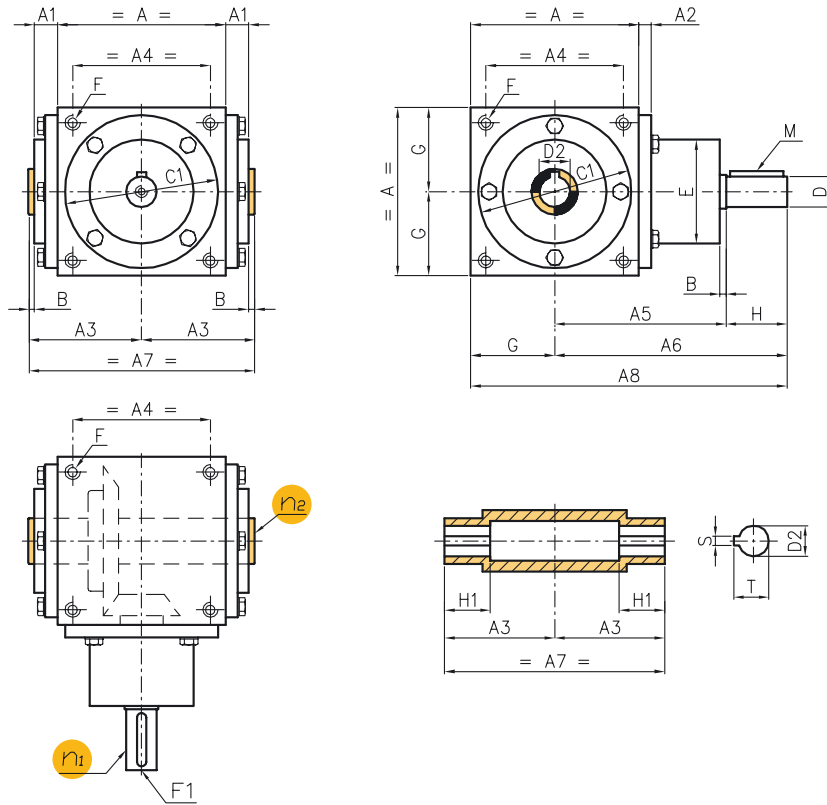

Hollow shaft bevel gearbox RC

XRC Models*

Size	54	86	110	134	166	200	250	350	500
A	54	86	110	134	166	200	250	350	500
A1	8,5	15	15	18	21	23	22	30	35
A2	10	10	8	9	11	11	11	15	20
A3	37	60	72	87	106	125	150	210	295
A4	44	70	90	114	144	174	216	320	450
A5	72	84	110	132	152	182	218	330	415
A6	95	114	150	182	217	267	318	450	585
A7	74	120	144	174	212	250	300	420	590
A8	122	157	205	249	300	367	443	625	835
B	1,5	2	2	2	2	2	3	5	10
C1 Ø f7	53	84	100	122	156	185	230	345	485
D Ø h7	11	16	20	24	32	42	55	65	120
D2 Ø H7	12	16	20	24	32	42	55	80	120
E Ø	52,8	59	68	80	107	120	152	240	320
F	M4x12	M8x20	M10x25	M10x25	M12x30	M14x35	M16x40	M20x60	M30x80
F1	M4x10	M6x12	M8x20	M8x20	M10x25	M10x25	M12x25	M12x25	M20x50
G	27	43	55	67	83	100	125	175	250
H	23	30	40	50	65	85	100	120	170
H1	22	30	30	35	45	50	55	65	100
M	4x4x20	5x5x25	6x6x35	8x7x45	10x8x60	12x8x80	16x10x90	18x11x110	32x18x150
S	4	5	6	8	10	12	16	22	32
T	13,8	18,3	22,8	27,3	35,3	45,3	59,3	85,4	127,4

* XRC model: stainless steel version



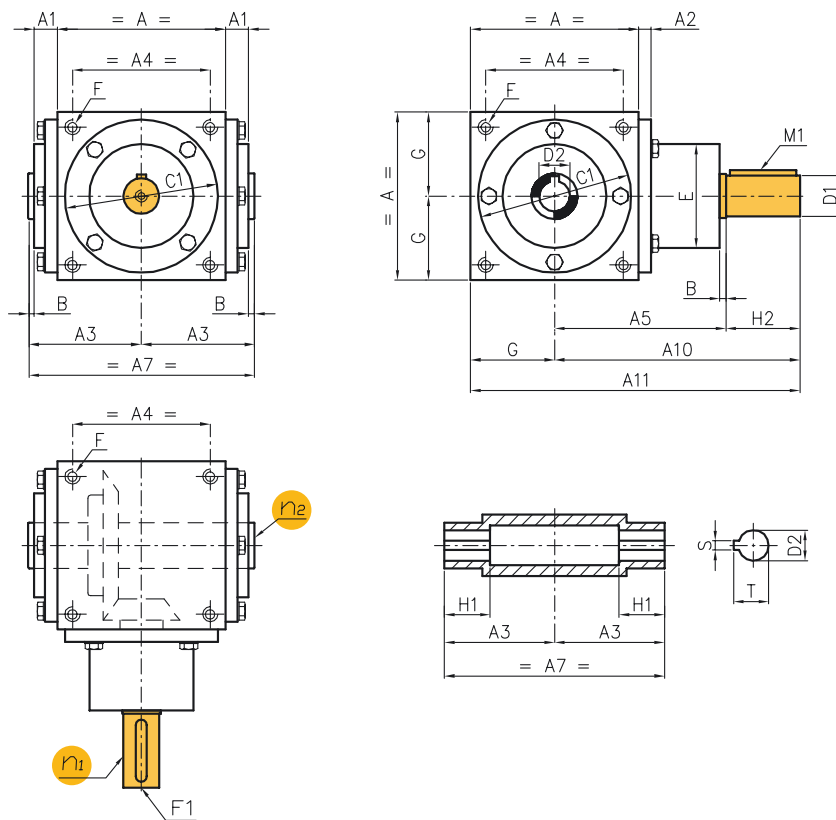

Basic constructive forms

ratio:
1/1



C1

ratio:
1/1,5 - 1/2 - 1/3 - 1/4



C2

Hollow shaft bevel gearbox with reinforced hub shaft RR

XRR Models*

Size	86	110	134	166	200	250	350	500
A	86	110	134	166	200	250	350	500
A1	15	15	18	21	23	22	30	35
A2	10	8	9	11	11	11	15	20
A3	60	72	87	106	125	150	210	295
A4	70	90	114	144	174	216	320	450
A5	84	110	132	152	182	218	330	415
A7	120	144	174	212	250	300	420	590
A10	134	165	197	242	292	358	500	625
A11	177	220	264	325	392	483	675	875
B	2	2	2	2	2	3	5	10
C1 Ø f7	84	100	122	156	185	230	345	485
D1 Ø h7	24	26	32	45	55	70	85	140
D2 Ø H7	16	20	24	32	42	55	80	120
E Ø	59	68	80	107	120	152	240	320
F	M8x20	M10x25	M10x25	M12x30	M14x35	M16x40	M20x60	M30x80
F1	M6x12	M8x20	M8x20	M10x25	M10x25	M12x25	M12x25	M20x50
G	43	55	67	83	100	125	175	250
H1	30	30	35	45	50	55	65	100
H2	50	55	65	90	110	140	170	210
M1	8x7x40	8x7x45	10x8x55	14x9x80	16x10x100	20x12x120	22x14x150	36x20x200
S	5	6	8	10	12	12	22	32
T	18,3	22,8	27,3	35,3	45,3	59,3	85,4	127,4

* XRR model: stainless steel version

Basic constructive forms

ratio:
1/1



C1

ratio:
1/1,5 - 1/2 - 1/3 - 1/4



C2

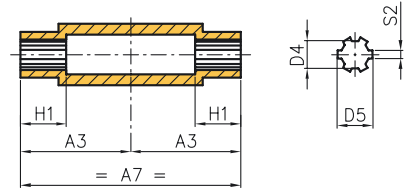
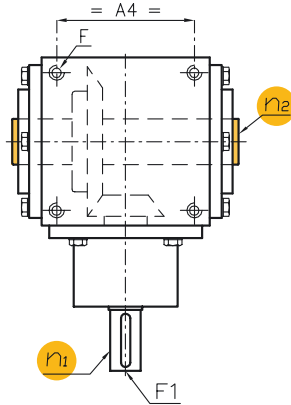
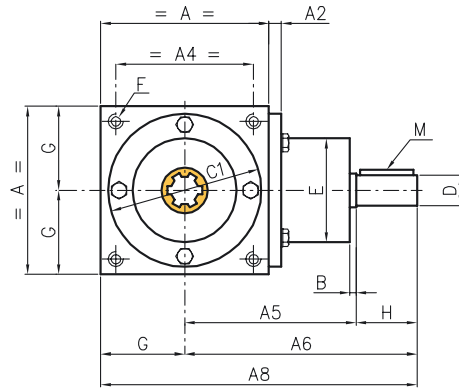
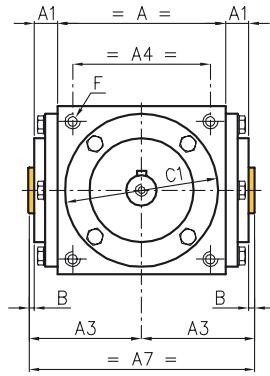

Broached hollow shaft bevel gear box RB

XRB Models*

Size	54	86	110	134	166	200	250	350	500
A	54	86	110	134	166	200	250	350	500
A1	8,5	15	15	18	21	23	22	30	35
A2	10	10	8	9	11	11	11	15	20
A3	37	60	72	87	106	125	150	210	295
A4	44	70	90	114	144	174	216	320	450
A5	72	84	110	132	152	182	218	330	415
A6	95	114	150	182	217	267	318	450	585
A7	74	120	144	174	212	250	300	420	590
A8	122	157	205	249	300	367	443	625	835
B	1,5	2	2	2	2	2	3	5	10
C1 Ø f7	53	84	100	122	156	185	230	345	485
D Ø h7	11	16	20	24	32	42	55	65	120
D4 Ø H7	11	13	18	21	28	36	46	72	102
D5 Ø H10	14	16	22	25	34	42	54	82	112
E Ø	52,8	59	68	80	107	120	152	240	320
F	M4x12	M8x20	M10x25	M10x25	M12x30	M14x35	M16x40	M20x60	M30x80
F1	M4x10	M6x12	M8x20	M8x20	M10x25	M10x25	M12x25	M12x25	M20x50
G	27	43	55	67	83	100	125	175	250
H	23	30	40	50	65	85	100	120	170
H5	13	15	20	25	30	35	40	50	65
M	4x4x20	5x5x25	6x6x35	8x7x45	10x8x60	12x8x80	16x10x90	18x11x110	32x18x150
S2 H9	3	3,5	5	5	7	7	9	12	16
Number of slots	6	6	6	6	6	8	8	10	10
Broached shaft UNI 8953 NT	6x11x14	6x13x16	6x18x22	6x21x25	6x28x34	8x36x42	8x46x54	10x72x82	10x102x112

The broached shaft which is to be coupled with the hollow shaft of the bevel gearbox must respect the following tolerance parameters, depending on whether it is sliding or fixed.

Size	54	86	110	134	166	200	250	350	500
Sliding coupling									
D5 a11	14	16	22	25	34	42	54	82	112
D4 f7	11	13	18	21	28	36	46	72	102
S2 d10	3	3,5	5	5	7	7	9	12	16
Fixed coupling									
D5 a11	14	16	22	25	34	42	54	82	112
D4 h7	11	13	18	21	28	36	46	72	102
S2 h10	3	3,5	5	5	7	7	9	12	16

* XRB model: stainless steel version



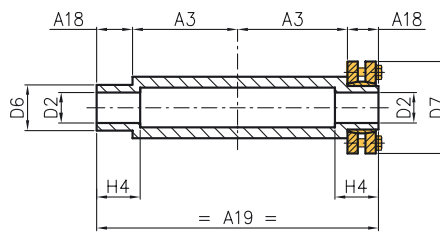
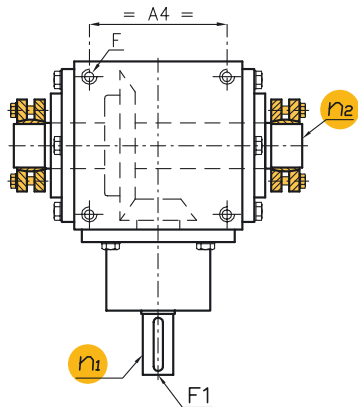
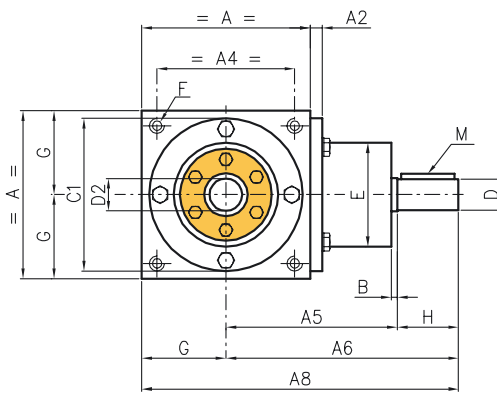
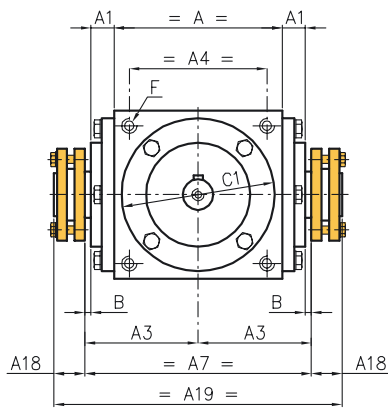

Basic constructive forms

ratio:
1/1



C1

ratio:
1/1,5 - 1/2 - 1/3 - 1/4



C2

Hollow shaft bevel gearbox with shrink-disk RA

XRA Models*

Size	54	86	110	134	166	200	250	350	500
A	54	86	110	134	166	200	250	350	500
A1	8,5	15	15	18	21	23	22	30	35
A2	10	10	8	9	11	11	11	15	20
A3	37	60	72	87	106	125	150	210	295
A4	44	70	90	114	144	174	216	320	450
A5	72	84	110	132	152	182	218	330	415
A6	95	114	150	182	217	267	318	450	585
A7	74	120	144	174	212	250	300	420	590
A8	122	157	205	249	300	367	443	625	835
A18	15	23	23	25	30	32	35	50	75
A19	104	166	190	224	272	314	370	370	740
B	1,5	2	2	2	2	2	3	5	10
C1 Ø f7	53	84	100	122	156	185	230	345	485
D Ø h7	11	16	20	24	32	42	55	65	120
D2 Ø H7	12	16	20	24	32	42	55	80	120
D6 Ø h7	14	24	24	30	44	50	68	100	160
D7 Ø	38	50	50	60	80	90	115	170	265
E Ø	52,8	59	68	80	107	120	152	240	320
F	M4x12	M8x20	M10x25	M10x25	M12x30	M14x35	M16x40	M20x60	M30x80
F1	M4x10	M6x12	M8x20	M8x20	M10x25	M10x25	M12x25	M12x25	M20x50
G	27	43	55	67	83	100	125	175	250
H	23	30	40	50	65	85	100	120	170
H4	22	30	30	35	45	50	55	65	90
M	4x4x20	5x5x25	6x6x35	8x7x45	10x8x60	12x8x80	16x10x90	18x11x110	32x18x150

Size	54	86	110	134	166	200	250	350	500
Torque moment Mt [daNm]	5	12	21	30	62	138	250	900	2860
Axial force Fa [daN]	900	1900	2700	2900	6400	9200	10600	24000	51000
Fastening n. of screws	4xM5	6xM5	6xM5	7xM5	7xM6	8xM6	10xM6	12xM8	12xM12
Torque [daNm]	0,4	0,4	0,4	0,4	1,2	1,2	1,2	3	10

* XRA model: stainless steel version

The table on the left shows the characteristic values for each single shrink-disk.

Basic constructive forms

ratio:
1/1



ratio:
1/1,5 - 1/2 - 1/3 - 1/4

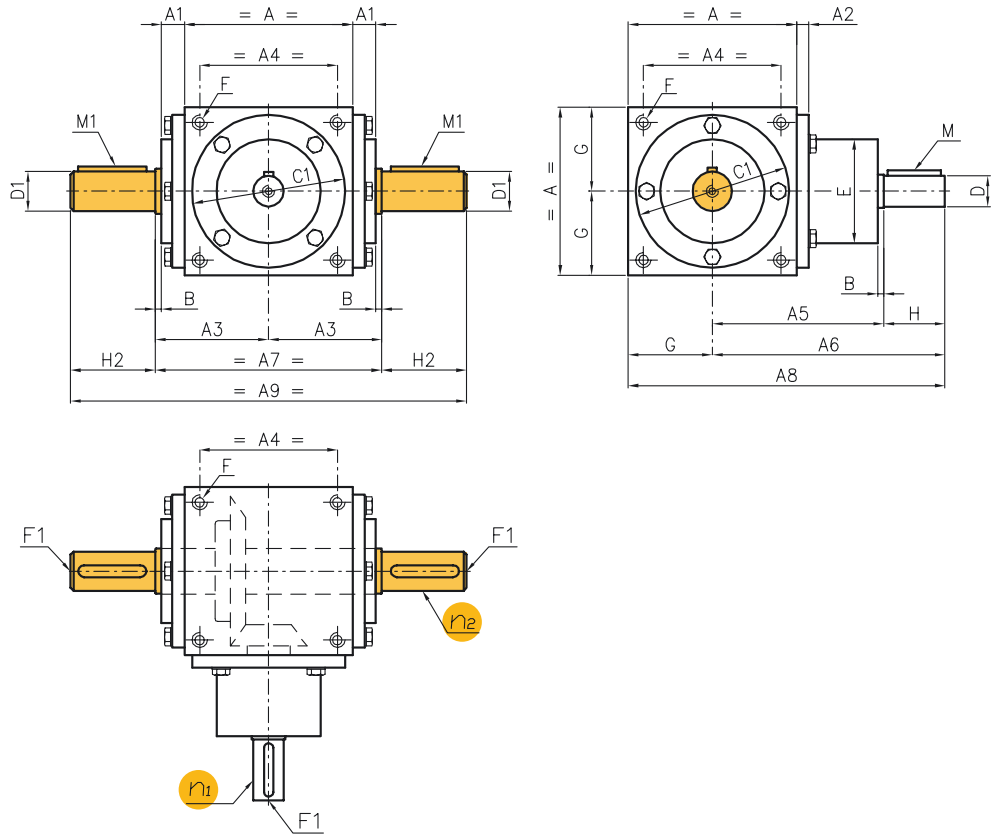

Protruding shaft level gearbox RS

XRS Models*

Size	54	86	110	134	166	200	250	350	500
A	54	86	110	134	166	200	250	350	500
A1	8,5	15	15	18	21	23	22	30	35
A2	10	10	8	9	11	11	11	15	20
A3	37	60	72	87	106	125	150	210	295
A4	44	70	90	114	144	174	216	320	450
A5	72	84	110	132	152	182	218	330	415
A6	95	114	150	182	217	267	318	450	585
A7	74	120	144	174	212	250	300	420	590
A8	122	157	205	249	300	367	443	625	835
A9	144	220	254	304	392	470	580	760	1010
B	1,5	2	2	2	2	2	3	5	10
C1 Ø f7	53	84	100	122	156	185	230	345	485
D Ø h7	11	16	20	24	32	42	55	65	120
D1 Ø H7	18	24	26	32	45	55	70	85	140
E Ø	52,8	59	68	80	107	120	152	240	320
F	M4x12	M8x20	M10x25	M10x25	M12x30	M14x35	M16x40	M20x60	M30x80
F1	M4x10	M6x12	M8x20	M8x20	M10x25	M10x25	M12x25	M12x25	M20x50
G	27	43	55	67	83	100	125	175	250
H	23	30	40	50	65	85	100	120	170
H2	35	50	55	65	90	110	140	170	210
M	4x4x20	5x5x25	6x6x35	8x7x45	10x8x60	12x8x80	16x10x90	18x11x110	32x18x150
M1	6x6x30	8x7x40	8x7x45	10x8x55	14x9x80	16x10x100	20x12x120	22x14x150	36x20x200

* XRS model: stainless steel version



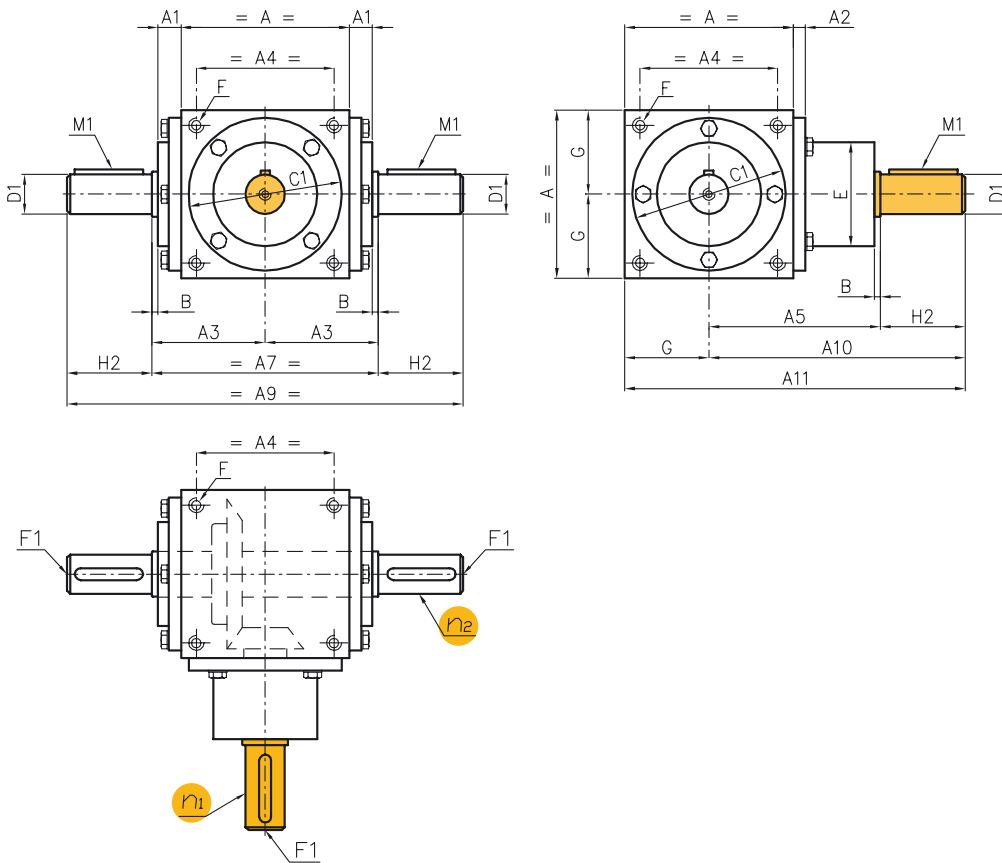

Protruding shaft bevel gearbox with reinforced hub-shaft RP

XRP Models*

Size	86	110	134	166	200	250	350	500
A	86	110	134	166	200	250	350	500
A1	15	15	18	21	23	22	30	35
A2	10	8	9	11	11	11	15	20
A3	60	72	87	106	125	150	210	295
A4	70	90	114	144	174	216	320	450
A5	84	110	132	152	182	218	330	415
A7	120	144	174	212	250	300	420	590
A9	220	254	304	392	470	580	760	1010
A10	134	165	197	242	292	358	500	625
A11	177	220	264	325	392	483	675	875
B	2	2	2	2	2	3	5	10
C1 \varnothing f7	84	100	122	156	185	230	345	485
D1 \varnothing h7	24	26	32	45	55	70	85	140
E \varnothing	59	68	80	107	120	152	240	320
F	M8x20	M10x25	M10x25	M12x30	M14x35	M16x40	M20x60	M30x80
F1	M6x12	M8x20	M8x20	M10x25	M10x25	M12x25	M12x25	M20x50
G	43	55	67	83	100	125	175	250
H2	50	55	65	90	110	140	170	210
M1	8x7x40	8x7x45	10x8x55	14x9x80	16x10x100	20x12x120	22x14x150	36x20x200

* XRP model: stainless steel version

Basic constructive forms

ratio:
1/1



S1



S3



S4

ratio:

1/1,5 - 1/2 - 1/3 - 1/4



S2



S9



S10

protruding shaft bevel gearboxes

Basic constructive forms

ratio:
1/1



S31

ratio:
1/1,5 - 1/2 - 1/3 - 1/4



S32

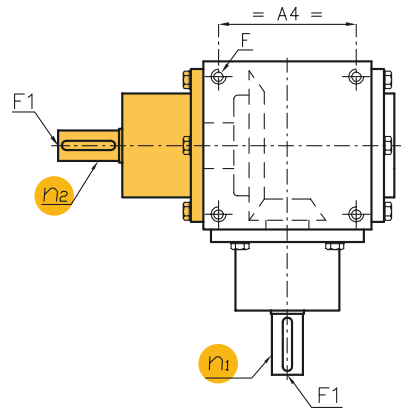
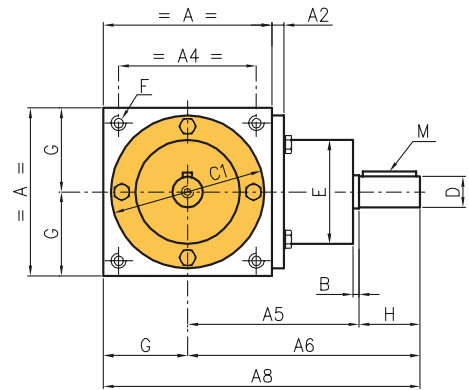
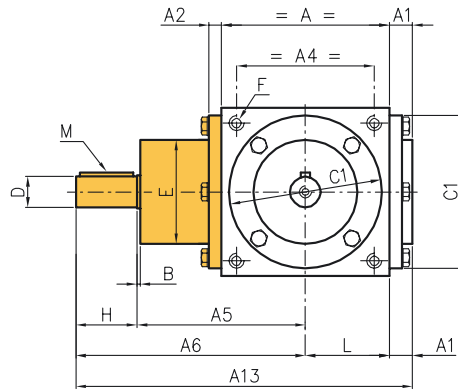

Double hub bevel gearbox RX

XRX Models*

Size	54	86	110	134	166	200	250	350	500
A	54	86	110	134	166	200	250	350	500
A1	8,5	15	15	18	21	23	22	30	35
A2	10	10	8	9	11	11	11	15	20
A4	44	70	90	114	144	174	216	320	450
A5	72	84	110	132	152	182	218	330	415
A6	95	114	150	182	217	267	318	450	585
A8	122	157	205	249	300	367	443	625	835
A13	157,5	172	220	267	321	390	465	655	870
B	1,5	2	2	2	2	2	3	5	10
C1 Ø f7	53	84	100	122	156	185	230	345	485
D Ø h7	11	16	20	24	32	42	55	65	120
E Ø	52,8	59	68	80	107	120	152	240	320
F	M4x12	M8x20	M10x25	M10x25	M12x30	M14x35	M16x40	M20x60	M30x80
F1	M4x10	M6x12	M8x20	M8x20	M10x25	M10x25	M12x25	M12x25	M20x50
G	27	43	55	67	83	100	125	175	250
H	23	30	40	50	65	85	100	120	170
M	4x4x20	5x5x25	6x6x35	8x7x45	10x8x60	12x8x80	16x10x90	18x11x110	32x18x150

* XRX model: stainless steel version



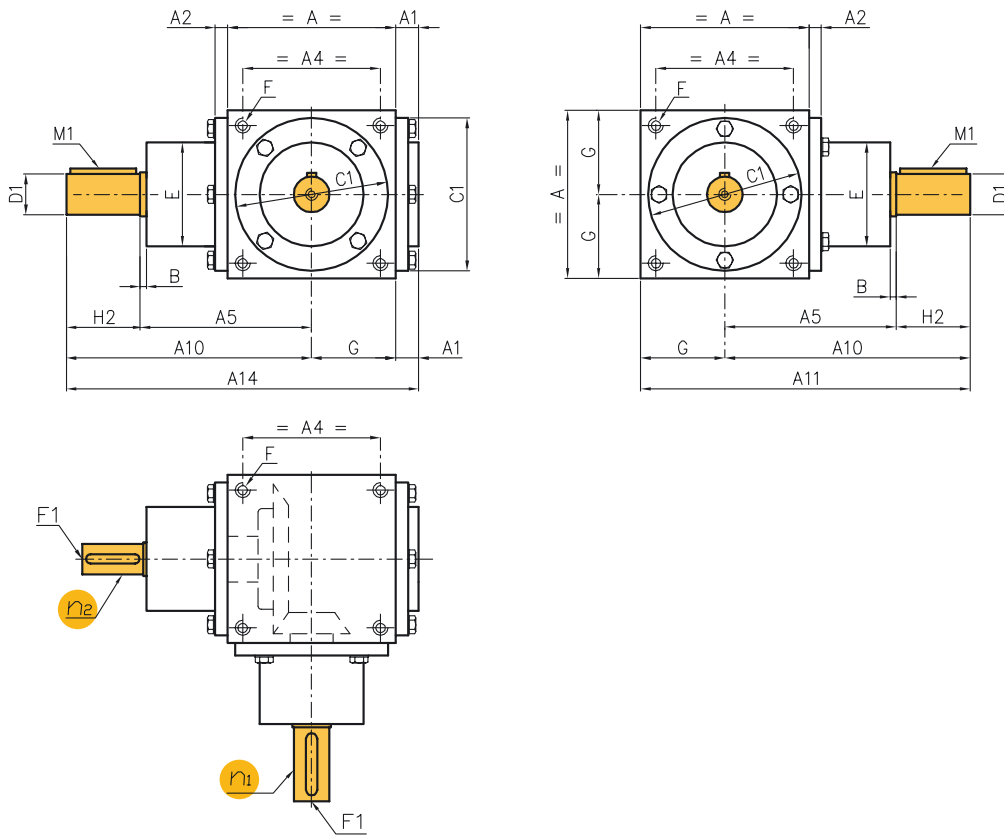

Basic constructive forms

ratio:
1/1



S31

ratio:

1/1,5 - 1/2 - 1/3 - 1/4



S32

Double hub bevel gearbox with reinforced shafts RZ

XRZ Models*

Size	86	110	134	166	200	250	350	500
A	86	110	134	166	200	250	350	500
A1	15	15	18	21	23	22	30	35
A2	10	8	9	11	11	11	15	20
A4	70	90	114	144	174	216	320	450
A5	84	110	132	152	182	218	330	415
A10	134	165	197	242	292	358	500	625
A11	177	220	264	325	392	483	675	875
A14	192	235	282	346	415	505	705	910
B	2	2	2	2	2	3	5	10
C1 Ø f7	84	100	122	156	185	230	345	485
D1 Ø h7	24	26	32	45	55	70	85	140
E Ø	59	68	80	107	120	152	240	320
F	M8x20	M10x25	M10x25	M12x30	M14x35	M16x40	M20x60	M30x80
F1	M6x12	M8x20	M8x20	M10x25	M10x25	M12x25	M12x25	M20x50
G	43	55	67	83	100	125	175	250
H2	50	55	65	90	110	140	170	210
M1	8x7x40	8x7x45	10x8x55	14x9x80	16x10x100	20x12x120	22x14x150	36x20x200

* XRZ model: stainless steel version

Basic constructive forms

ratio:
1/1,5



RM-S1



RM-S2



RM-S3



RM-S4



RM-S9



RM-S10

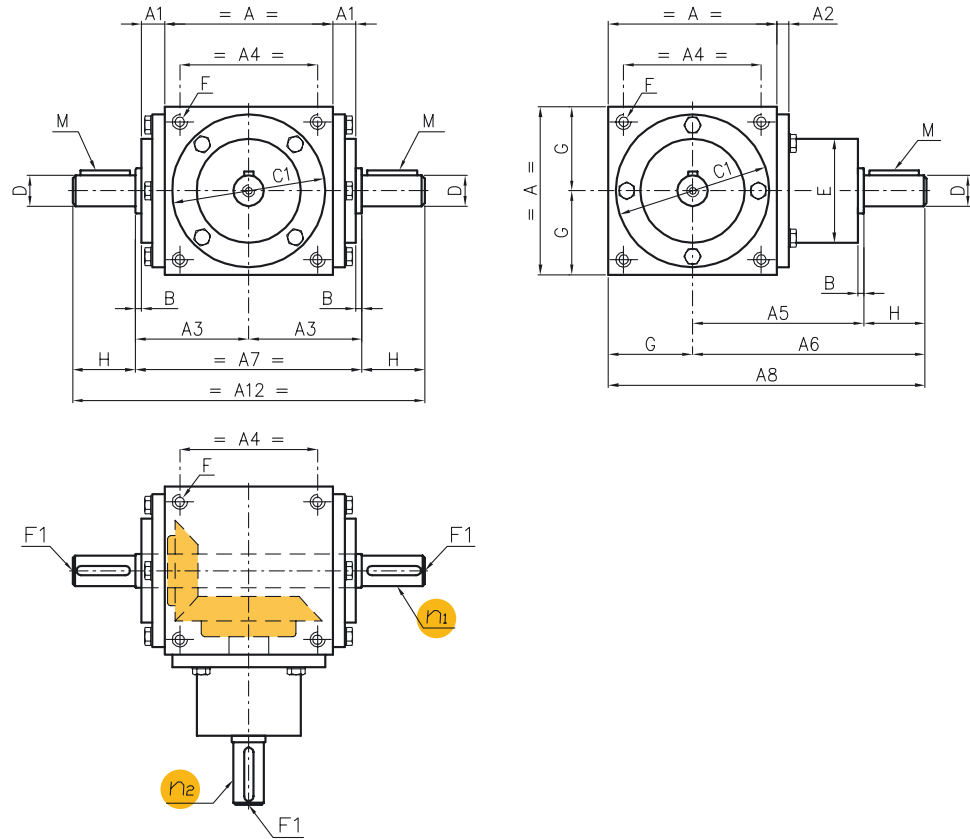

Bevel gearbox with fast protruding shafts RM

XRM Models*

Size	54	86	110	134	166	200	250	350	500
A	54	86	110	134	166	200	250	350	500
A1	8,5	15	15	18	21	23	22	30	35
A2	10	10	8	9	11	11	11	15	20
A3	37	60	72	87	106	125	150	210	295
A4	44	70	90	114	144	174	216	320	450
A5	72	84	110	132	152	182	218	330	415
A6	95	114	150	182	217	267	318	450	385
A7	74	120	144	174	212	250	300	420	590
A8	122	157	205	249	300	367	443	625	835
A12	120	180	224	274	342	420	500	660	930
B	1,5	2	2	2	2	2	3	5	10
C1 \varnothing f7	53	84	100	122	156	185	230	345	485
D \varnothing h7	11	16	20	24	32	42	55	65	120
E \varnothing	52,8	59	68	80	107	120	152	240	320
F	M4x12	M8x20	M10x25	M10x25	M12x30	M14x35	M16x40	M20x60	M30x80
F1	M4x10	M6x12	M8x20	M8x20	M10x25	M10x25	M12x25	M12x25	M20x50
G	27	43	55	67	83	100	125	175	250
H	23	30	40	50	65	85	100	120	170
M	4x4x20	5x5x25	6x6x35	8x7x45	10x8x60	12x8x80	16x10x90	18x11x110	32x18x150

* XRM model: stainless steel version



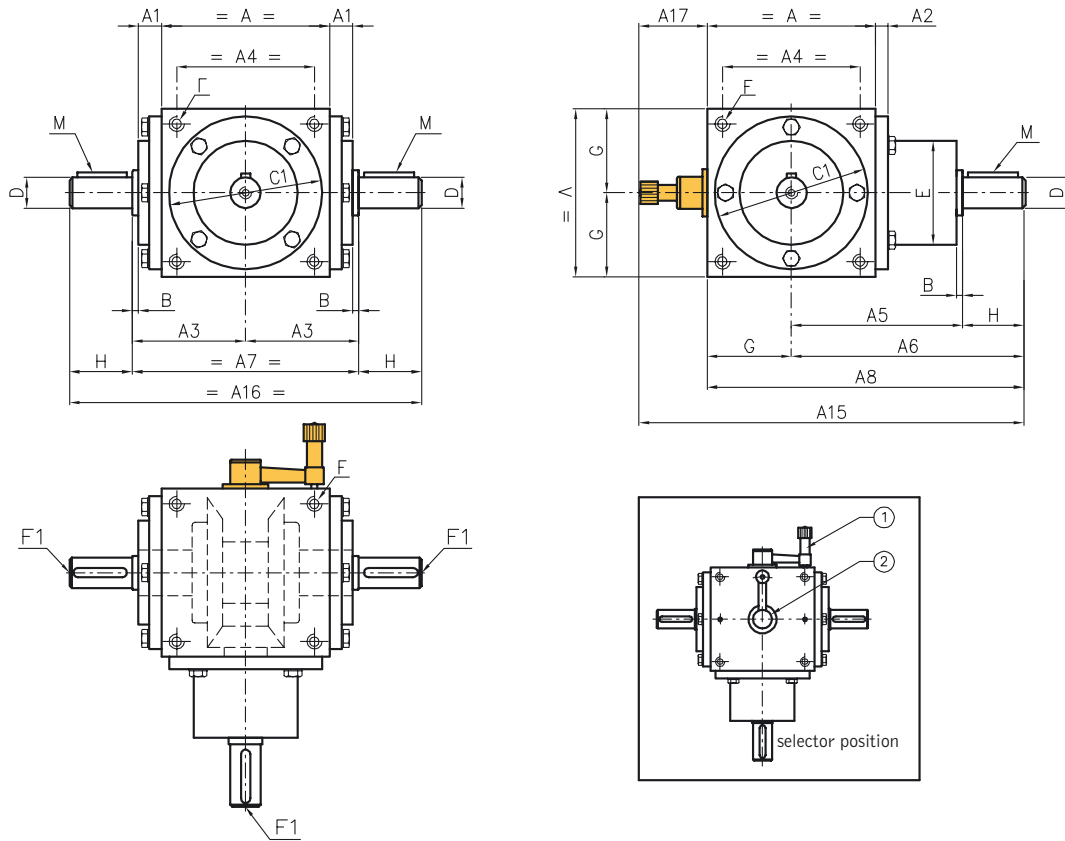

Basic constructive forms

ratio:
1/1 - 1/2



RIS-A



RIS-B



RIS-C

Bevel gearbox with inverter RIS

Size	134	166	200	250
A	134	166	200	250
A1	18	21	23	22
A2	9	11	11	11
A3	87	106	125	150
A4	114	144	174	216
A5	132	152	182	218
A6	177	217	267	318
A7	174	212	250	300
A8	249	300	367	443
A15	333	384	451	527
A16	264	342	420	500
A17	84	84	84	84
B	2	2	2	3
C1 Ø f7	122	156	185	230
D Ø h7	32	42	55	65
E Ø	80	107	120	152
F	M10x25	M12x30	M14x35	M16x40
F1	M8x20	M10x25	M10x25	M12x25
G	67	83	100	125
H	50	65	85	100
H3	45	60	85	100
M	10x8x40	12x8x50	16x10x70	16x10x90

In A and B versions, the lever enables the selection of : inserted shaft or idle shaft.

In C version the lever enables the selection of: inserted shaft, inserted shaft with reversed revolution or neutral. The rotation directions depend on the position of the selection lever. The selection operation by means of the lever must be actuated only when shafts are not running.

ratio:
1/4,5 - 1/6 - 1/9 - 1/12

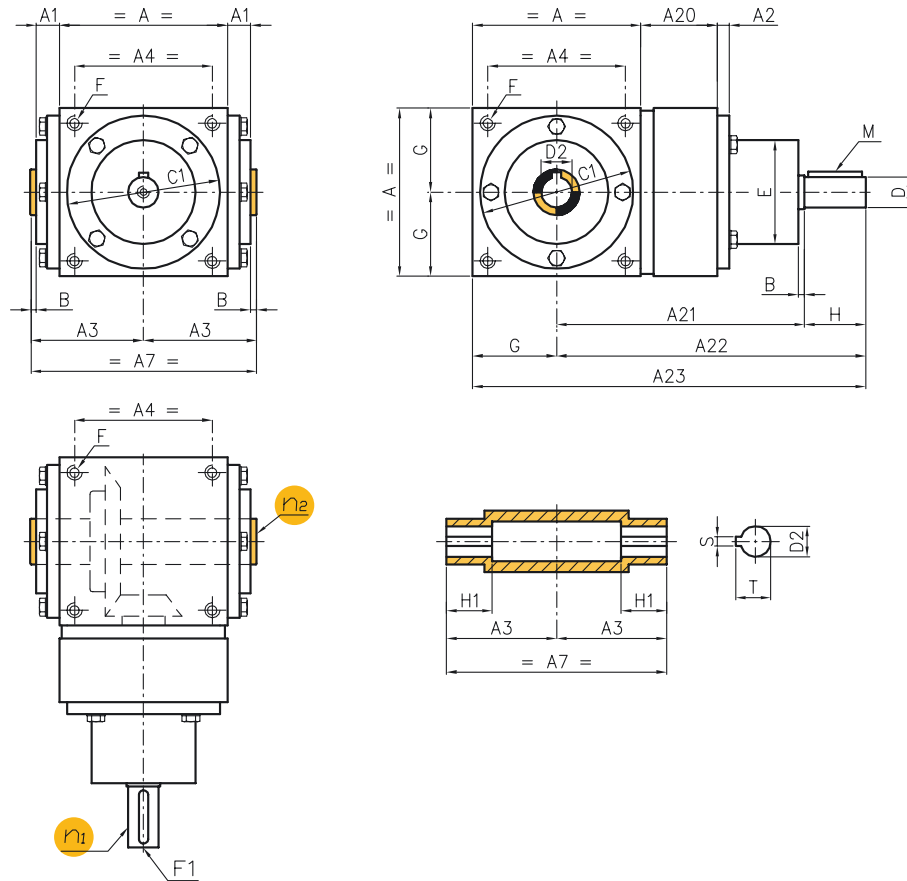

High reduction bevel gearbox with hollow shaft REC

Size	32	42	55
A	134	166	200
A1	18	21	23
A2	9	11	11
A4	114	144	174
A7	174	212	250
A20	88	98	128
A21	220	250	310
A22	270	315	395
A23	337	398	495
B	2	2	2
C1 \varnothing f7	122	156	185
D \varnothing h7	24	32	42
D2 \varnothing H7	24	32	42
E \varnothing	80	107	120
F	M10x25	M12x30	M14x35
F1	M8x20	M10x25	M10x25
G	67	83	100
H	50	65	85
H1	35	45	50
M	8x7x45	10x8x60	12x8x80
S	8	10	12
T	27,3	35,3	45,3



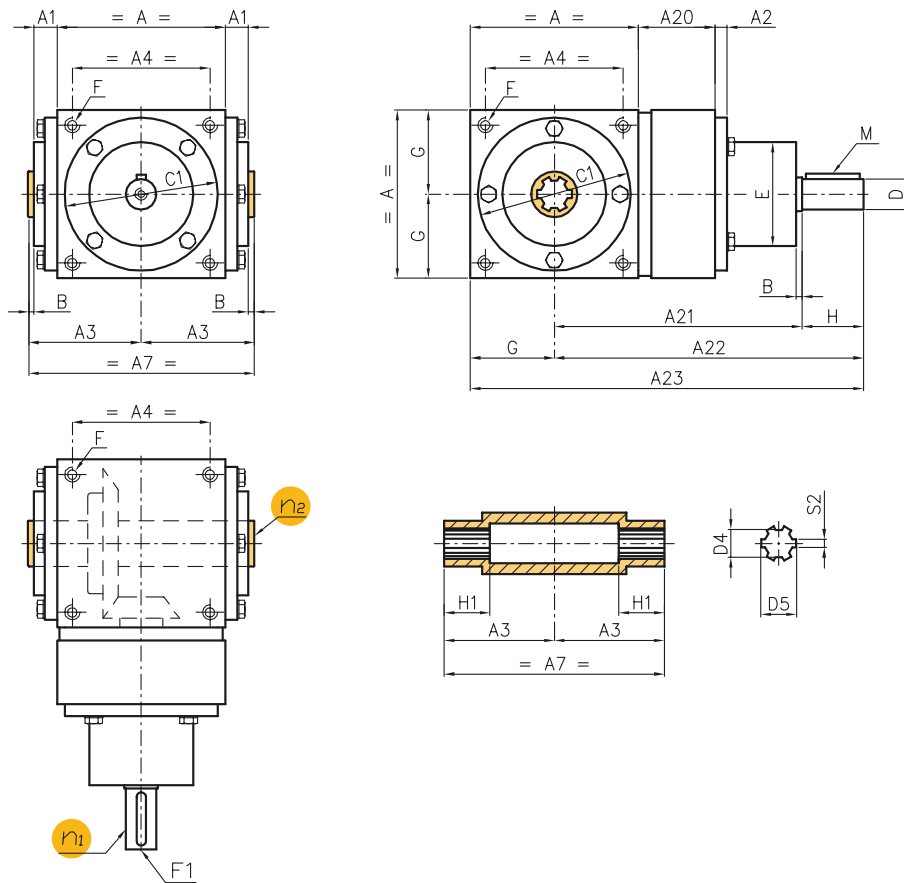

ratio:
1/4,5 - 1/6 - 1/9 - 1/12

High reduction bevel gearbox with broached hollow shaft REB

Size	32	42	55
A	134	166	200
A1	18	21	23
A2	9	11	11
A4	114	144	174
A7	174	212	250
A20	88	98	128
A21	220	250	310
A22	270	315	395
A23	337	398	495
B	2	2	2
C1 Ø f7	122	156	185
D Ø h7	24	32	42
D4 Ø H7	21	28	36
D5 Ø H10	25	34	42
E Ø	80	107	120
F	M10x25	M12x30	M14x35
F1	M8x20	M10x25	M10x25
G	67	83	100
H	50	65	85
H5	25	30	35
M	8x7x45	10x8x60	12x8x80
S2 H9	5	7	7
Number of slots	6	6	8
Broached shaft UNI 8953 NT	6x21x25	6x28x34	8x36x42

For the broached shaft characteristics make reference to RB models on page 200 (sizes 134, 166 and 200)

ratio:
1/4,5 - 1/6 - 1/9 - 1/12

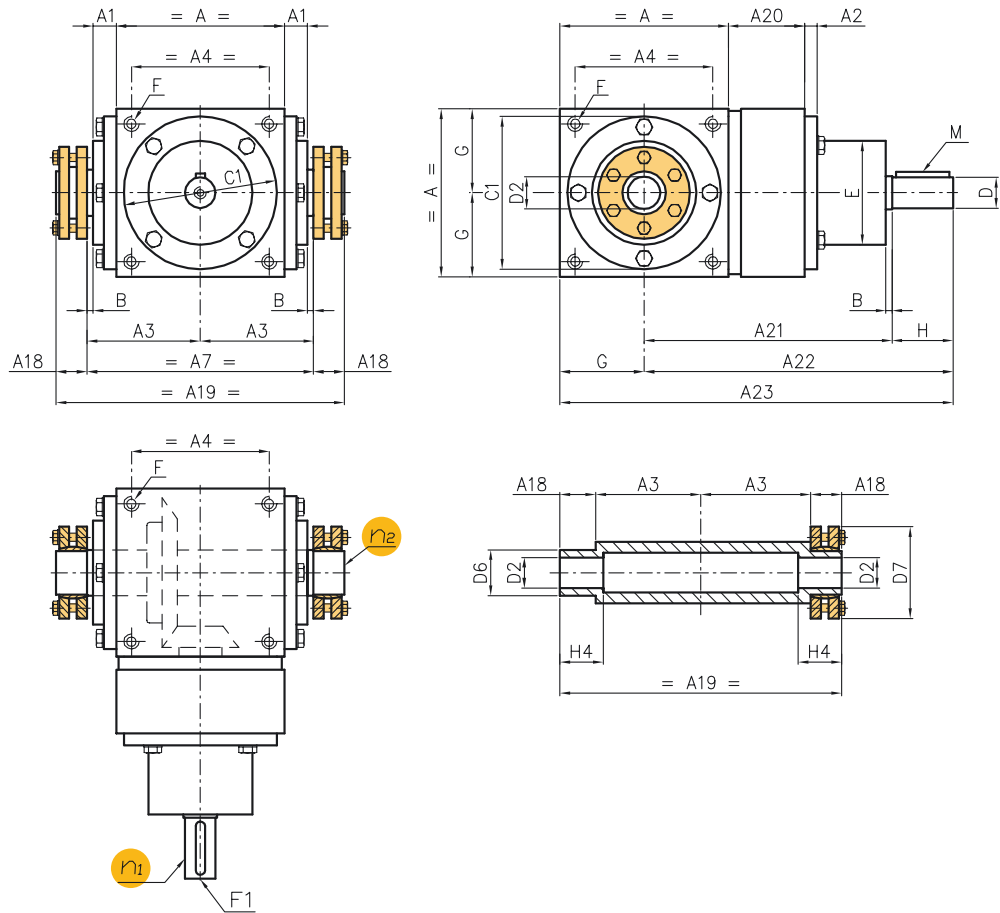

High reduction bevel gearbox with shrink disks REA

Size	32	42	55
A	134	166	200
A1	18	21	23
A2	9	11	11
A4	114	144	174
A7	174	212	250
A18	25	30	32
A20	88	98	128
A21	220	250	310
A22	270	315	395
A23	337	398	495
B	2	2	2
C1 Ø f7	122	156	185
D Ø h7	24	32	42
D2 Ø H7	24	32	42
D6 Ø h7	30	44	50
D7	60	80	90
E Ø	80	107	120
F	M10x25	M12x30	M14x35
F1	M8x20	M10x25	M10x25
G	67	83	100
H	50	65	85
H4	35	45	50
M	8x7x45	10x8x60	12x8x80

For the characteristics of shrink-disks, make reference to RA models on page 201 (sizes 134, 166 and 200)



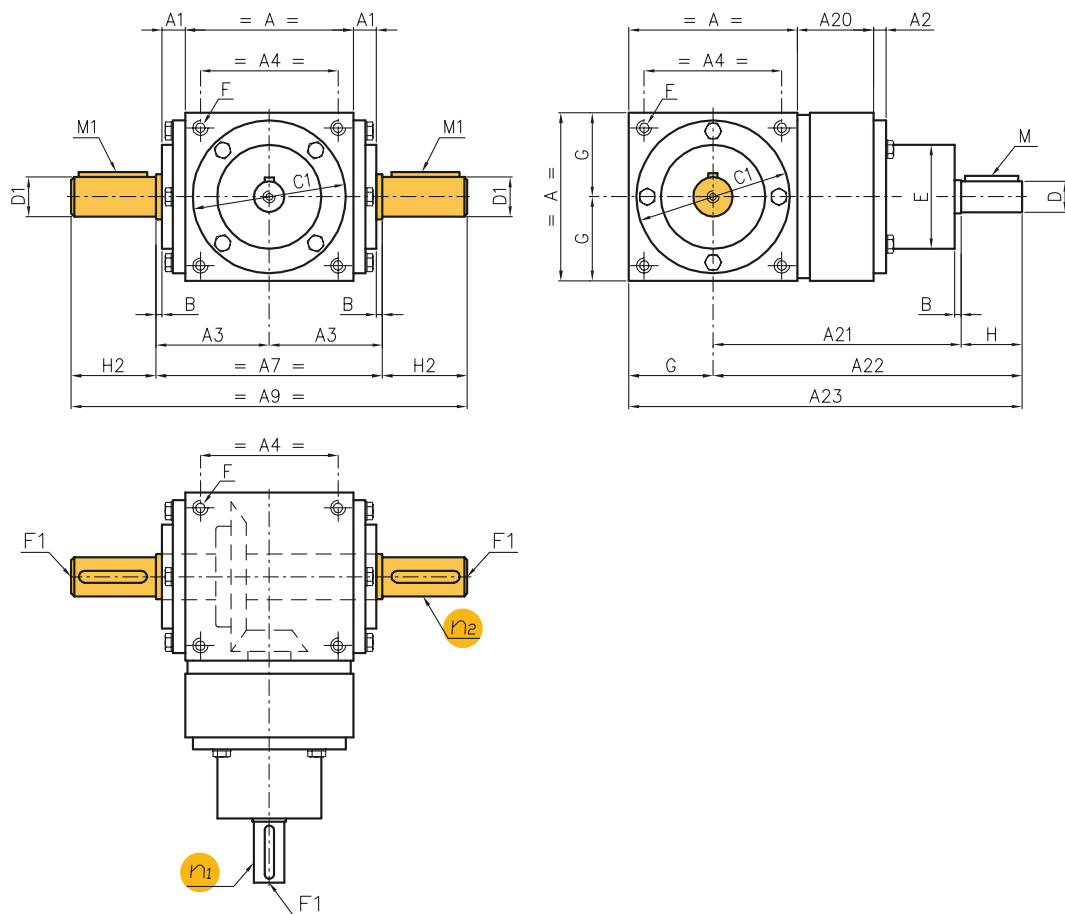

ratio:
1/4,5 - 1/6 - 1/9 - 1/12

High reduction bevel gearbox with protruding shaft RES

Size	32	42	55
A	134	166	200
A1	18	21	23
A2	9	11	11
A4	114	144	174
A7	174	212	250
A9	304	392	470
A20	88	98	128
A21	220	250	310
A22	270	315	395
A23	337	398	495
B	2	2	2
C1 \varnothing f7	122	156	185
D \varnothing h7	24	32	42
D1 \varnothing h7	32	45	55
E \varnothing	80	107	120
F	M10x25	M12x30	M14x35
F1	M8x20	M10x25	M10x25
G	67	83	100
H	50	65	85
H2	65	90	110
M	8x7x45	10x8x60	12x8x80
M1	10x8x45	14x9x80	16x10x100

ratio:
1/2 - 1/3

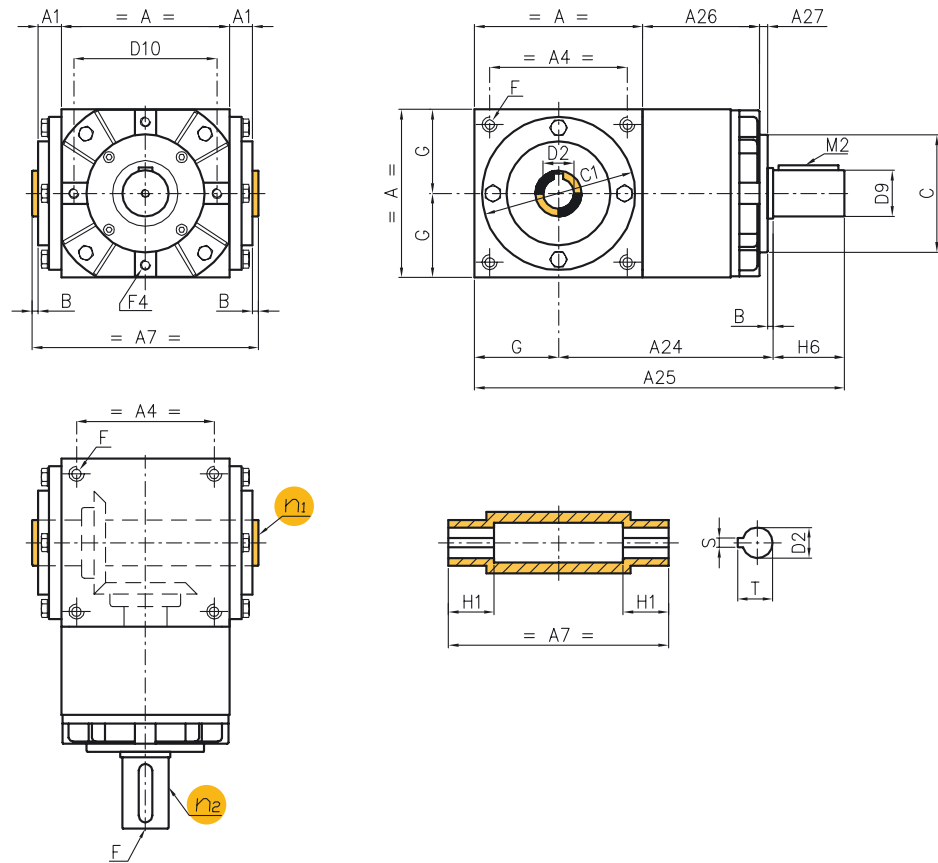

Inverted bevel gearbox with hollow shaft RHC

Size	32	42	55
A	134	166	200
A1	18	21	23
A4	114	144	174
A7	174	212	250
A24	174	203	249
A25	286	346	434
A26	97	110	139
A27	10	10	10
B	2	2	2
C $\varnothing_{-0.1}^{-0.2}$	99	116	140
C1 $\varnothing f7$	122	156	185
D2 $\varnothing h7$	24	32	42
D9 $\varnothing h7$	32	42	55
D10	116	140	170
F	M10x25	M12x30	M14x35
F3	M8x16	M10x20	M10x20
F4	M8x18	M10x20	M12x24
G	67	83	100
H1	35	45	50
H6	45	60	85
M2	10x8x40	12x8x50	16x10x70
S	8	10	12
T	27,3	35,3	45,3



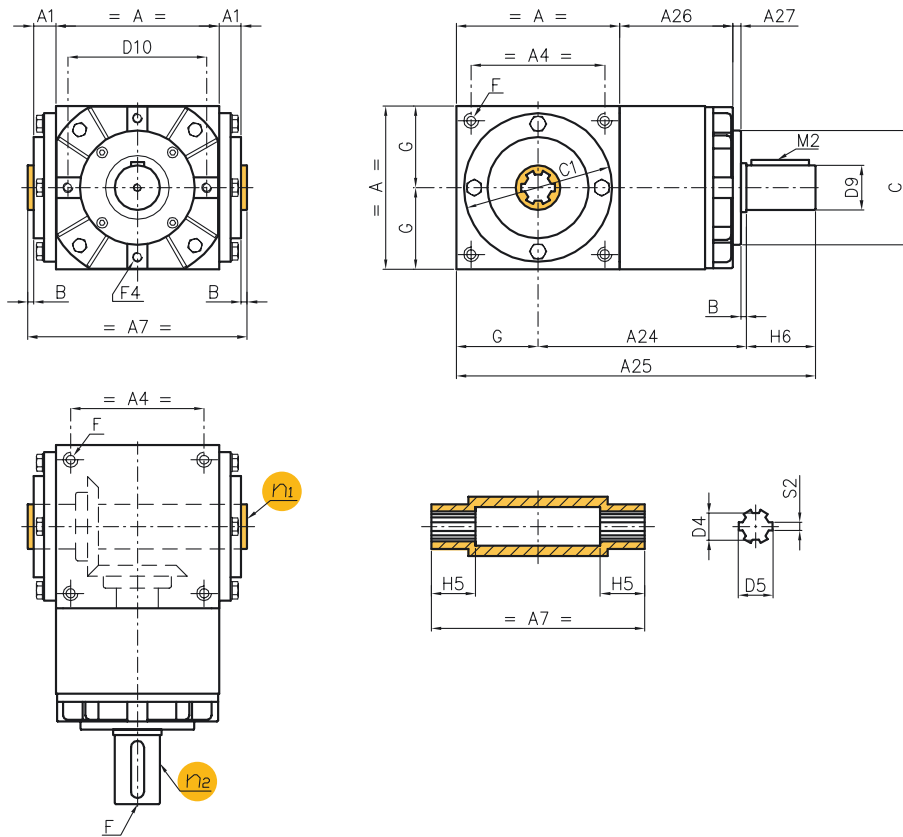

ratio:
1/2 - 1/3

Inverted bevel gearbox with broached hollow shaft RHB

Size	32	42	55
A	134	166	200
A1	18	21	23
A4	114	144	174
A7	174	212	250
A24	174	203	249
A25	286	346	434
A26	97	110	139
A27	10	10	10
B	2	2	2
C $\varnothing \begin{smallmatrix} 0 \\ -0,1 \\ -0,2 \end{smallmatrix}$	99	116	140
C1 $\varnothing f7$	122	156	185
D4 $\varnothing H7$	21	28	36
D5 $\varnothing H10$	25	34	42
D9 $\varnothing h7$	32	42	55
D10	116	140	170
F	M10x25	M12x30	M14x35
F3	M8x16	M10x20	M10x20
F4	M8x18	M10x20	M12x24
G	67	83	100
H5	25	30	35
H6	45	60	85
M2	10x8x40	12x8x50	16x10x70
S2 H9	5	7	7
N° holes	6	6	8
Broached shaft UNI 8953NT	6x21x25	6x28x34	8x36x42

For the broached shaft characteristics make reference to RB models on page 200 (sizes 134, 166 and 200)

ratio:
1/2 - 1/3

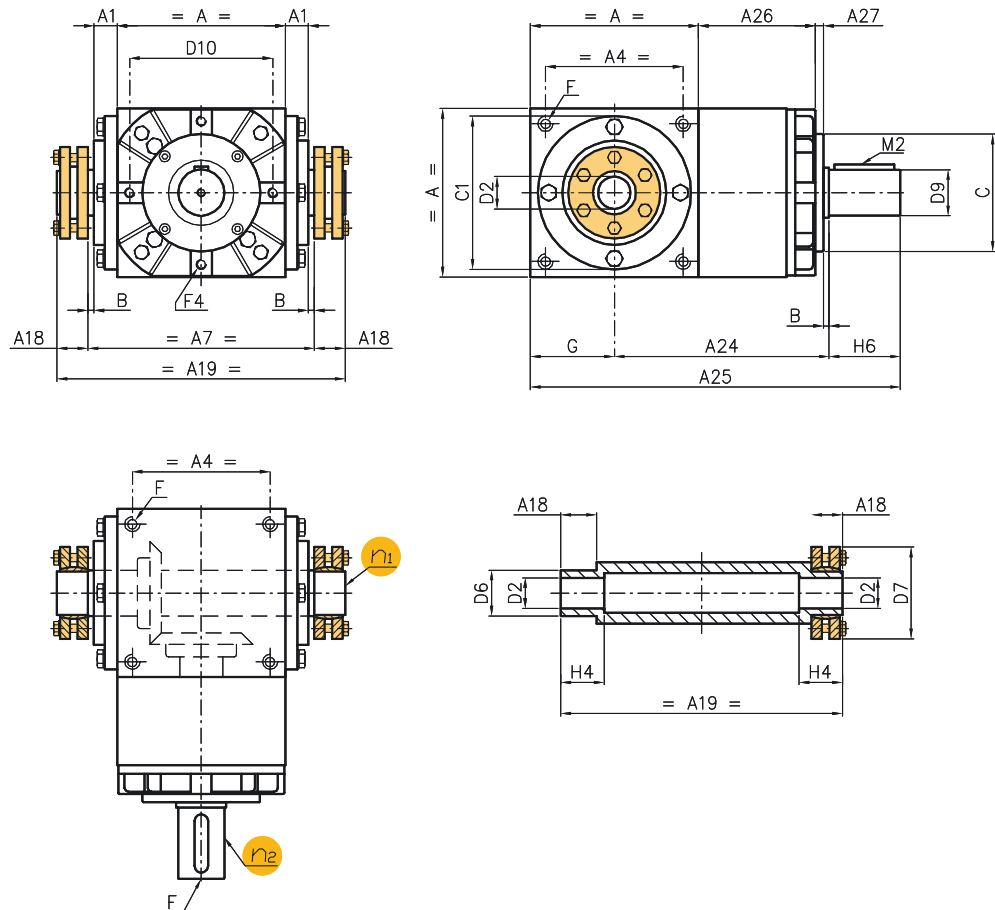

Inverted bevel gearbox with hollow shaft with shrink-disks RHA

Size	32	42	55
A	134	166	200
A1	18	21	23
A4	114	144	174
A7	174	212	250
A18	25	30	32
A24	174	203	249
A25	286	346	434
A26	97	110	139
A27	10	10	10
B	2	2	2
C $\varnothing_{-0.1}^{-0.2}$	99	116	140
C1 $\varnothing f7$	122	156	185
D2 $\varnothing H7$	24	32	42
D6 $\varnothing h7$	30	44	50
D7	60	80	90
D9 $\varnothing h7$	32	42	55
D10	116	140	170
F	M10x25	M12x30	M14x35
F3	M8x16	M10x20	M10x20
F4	M8x18	M10x20	M12x24
G	67	83	100
H4	35	45	50
H6	45	60	85
M2	10x8x40	12x8x50	16x10x70

For the characteristics of shrink-disks, make reference to RA models on page 201 (sizes 134, 166 and 200)



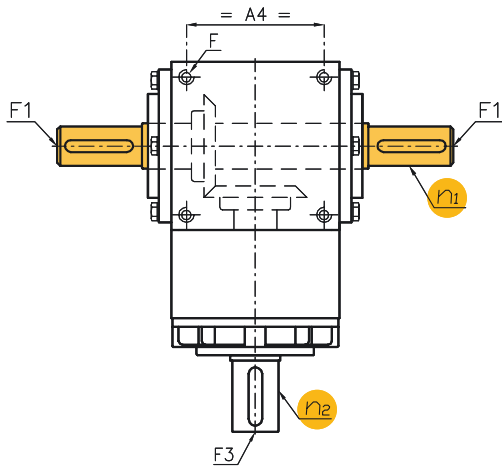
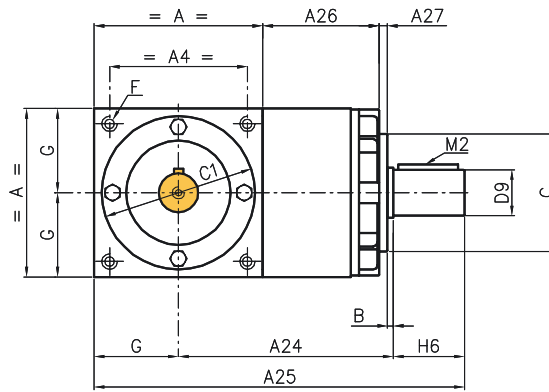
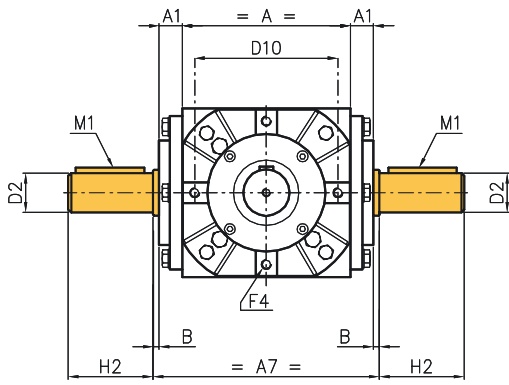

ratio:
1/2 - 1/3 - 1/4,5

Inverted gearbox with protruding shafts RHS

Size		32	42	55
A		134	166	200
A1		18	21	23
A4		114	144	174
A7		174	212	250
A24		174	203	249
A25		286	346	434
A26		97	110	139
A27		10	10	10
B		2	2	2
C \emptyset $^{-0.1}_{-0.2}$		99	116	140
C1 \emptyset f7		122	156	185
D2 \emptyset h7	Ratio 1/2 1/3	32	45	55
	Ratio 1/4,5	24	32	42
D9 \emptyset h7		32	42	55
D10		116	140	170
F		M10x25	M12x30	M14x35
F3		M8x16	M10x20	M10x20
F4		M8x18	M10x20	M12x24
G		67	83	100
H2	Ratio 1/2 1/3	65	90	110
	Ratio 1/4,5	50	65	85
H6		45	60	85
M1	Ratio 1/2 1/3	10x8x55	14x9x80	16x10x100
	Ratio 1/4,5	8x7x45	10x8x60	12x8x80
M2		10x8x40	12x8x50	16x10x70

Basic constructive forms

ratio:
1/1



ratio:
1/1,5 - 1/2 - 1/3 - 1/4

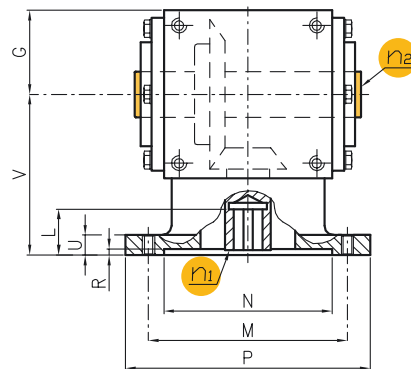
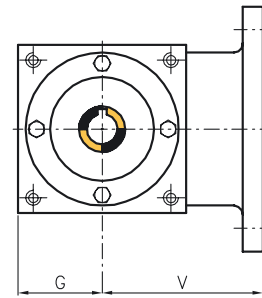
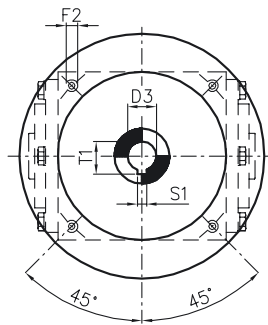

Hollow shaft motor gearbox MRC

Size	IEC flange	D3 H7	F2	G	L	M	N	P	R	S1	T1	U	V	
XMRC Models*	86	56 B5	9	M6	43	23	100	80	120	4	3	10,4	13	90
		63 B5	11	M8	43	23	115	95	140	4	4	12,8	13	90
		71 B5	14	M8	43	30	130	110	160	4	5	16,3	13	90
		71 B14	14	7	43	30	85	70	105	4	5	16,3	13	90
		80 B5	19	M10	43	40	165	130	200	4	6	21,8	13	100
		80 B14	19	7	43	40	100	80	120	4	6	21,8	13	100
	110	63 B5	11	M8	55	23	115	95	140	4	4	12,8	13	105
		71 B5	14	M8	55	30	130	110	160	4	5	16,3	13	105
		71 B14	14	7	55	30	85	70	105	4	5	16,3	13	105
		80 B5	19	M10	55	40	165	130	200	4	6	21,8	13	105
		80 B14	19	7	55	40	100	80	120	4	6	21,8	13	105
		134	71 B5	14	M8	67	30	130	110	160	5	5	16,3	13
	80 B5		19	M10	67	40	165	130	200	5	6	21,8	13	125
	80 B14		19	7	67	40	100	80	120	5	6	21,8	13	125
90 B5	24		M10	67	50	165	130	200	5	8	27,3	13	125	
90 B14	24		9	67	50	115	95	140	5	8	27,3	13	125	
100-112 B5	28		M12	67	60	215	180	250	5	8	31,3	13	135	
166	100-112 B14	28	9	67	60	130	110	160	5	8	31,3	13	135	
	71 B5	14	9	83	30	130	110	160	6	5	16,3	15	160	
	80 B5	19	M10	83	40	165	130	200	6	6	21,8	15	160	
	90 B5	24	M10	83	50	165	130	200	6	8	27,3	15	160	
	100-112 B5	28	M12	83	60	215	180	250	6	8	31,3	15	160	
200	100-112 B14	28	9	83	60	130	110	160	6	8	31,3	15	160	
	90 B5	24	11	100	50	165	130	200	6	8	27,3	23	220	
	100-112 B5	28	M12	100	60	215	180	250	6	8	31,3	23	220	
	132 B5	38	M12	100	80	265	230	300	6	10	41,3	23	220	
250	132 B14	38	11	100	80	165	130	200	6	10	41,3	23	220	
	132 B5	38	M12	125	80	265	230	300	6	10	41,3	25	250	
	132 B14	38	11	125	80	165	130	200	6	10	41,3	25	250	
	160 B5	42	M16	125	110	300	250	350	6	12	45,8	25	250	

* XMRC: stainless steel version

For non quoted dimensions make reference to the schemes on page 198.



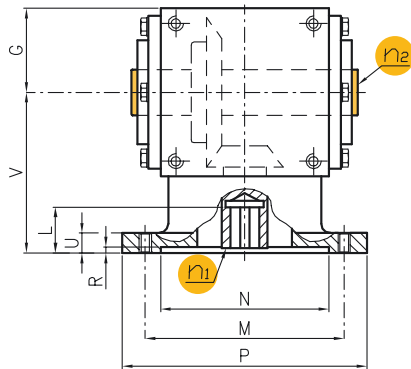
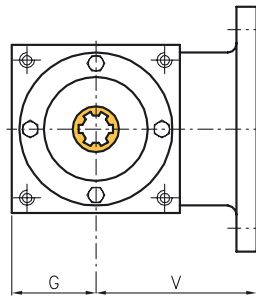
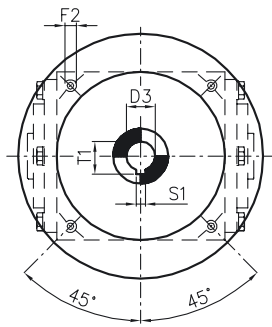

Basic constructive forms

ratio:
1/1



MC1

ratio:

1/1,5 - 1/2 - 1/3 - 1/4



MC2

Motor gearbox with broached hollow shaft MRB

Size	IEC flange	D3 H7	F2	G	L	M	N	P	R	S1	T1	U	V	
XMRB models*	86	56 B5	9	M6	43	23	100	80	120	4	3	10,4	13	90
		63 B5	11	M8	43	23	115	95	140	4	4	12,8	13	90
		71 B5	14	M8	43	30	130	110	160	4	5	16,3	13	90
		71 B14	14	7	43	30	85	70	105	4	5	16,3	13	90
		80 B5	19	M10	43	40	165	130	200	4	6	21,8	13	100
		80 B14	19	7	43	40	100	80	120	4	6	21,8	13	100
	110	63 B5	11	M8	55	23	115	95	140	4	4	12,8	13	105
		71 B5	14	M8	55	30	130	110	160	4	5	16,3	13	105
		71 B14	14	7	55	30	85	70	105	4	5	16,3	13	105
		80 B5	19	M10	55	40	165	130	200	4	6	21,8	13	105
		80 B14	19	7	55	40	100	80	120	4	6	21,8	13	105
	134	71 B5	14	M8	67	30	130	110	160	5	5	16,3	13	125
		80 B5	19	M10	67	40	165	130	200	5	6	21,8	13	125
		80 B14	19	7	67	40	100	80	120	5	6	21,8	13	125
90 B5		24	M10	67	50	165	130	200	5	8	27,3	13	125	
90 B14		24	9	67	50	115	95	140	5	8	27,3	13	125	
100-112 B5		28	M12	67	60	215	180	250	5	8	31,3	13	135	
166	100-112 B14	28	9	67	60	130	110	160	5	8	31,3	13	135	
	71 B5	14	9	83	30	130	110	160	6	5	16,3	15	160	
	80 B5	19	M10	83	40	165	130	200	6	6	21,8	15	160	
	90 B5	24	M10	83	50	165	130	200	6	8	27,3	15	160	
	100-112 B5	28	M12	83	60	215	180	250	6	8	31,3	15	160	
	100-112 B14	28	9	83	60	130	110	160	6	8	31,3	15	160	
200	90 B5	24	11	100	50	165	130	200	6	8	27,3	23	220	
	100-112 B5	28	M12	100	60	215	180	250	6	8	31,3	23	220	
	132 B5	38	M12	100	80	265	230	300	6	10	41,3	23	220	
	132 B14	38	11	100	80	165	130	200	6	10	41,3	23	220	
250	132 B5	38	M12	125	80	265	230	300	6	10	41,3	25	250	
	132 B14	38	11	125	80	165	130	200	6	10	41,3	25	250	
	160 B5	42	M16	125	110	300	250	350	6	12	45,8	25	250	

* XMRB: stainless steel version

For the characteristics of the broached shaft, make reference to RB models on page 200.

For non quoted dimensions make reference to the schemes on page 200.

Basic constructive forms

ratio:
1/1



MC1

ratio:
1/1,5 - 1/2 - 1/3 - 1/4



MC2

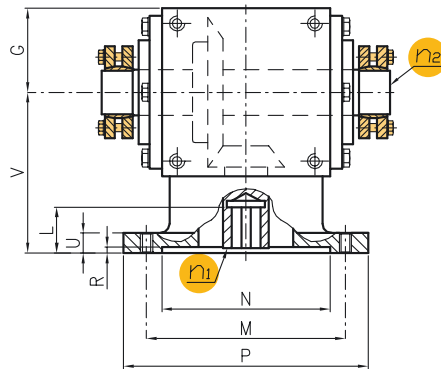
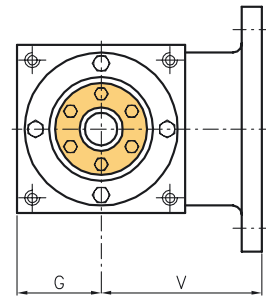
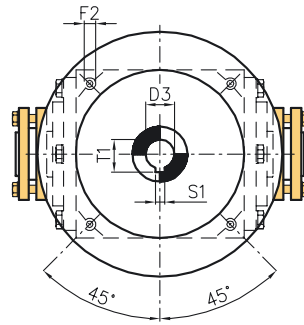

Hollow shaft motor gearbox with shrink disks MRA

Size	IEC flange	D3 H7	F2	G	L	M	N	P	R	S1	T1	U	V	
XMRA models*	86	56 B5	9	M6	43	23	100	80	120	4	3	10,4	13	90
		63 B5	11	M8	43	23	115	95	140	4	4	12,8	13	90
		71 B5	14	M8	43	30	130	110	160	4	5	16,3	13	90
		71 B14	14	7	43	30	85	70	105	4	5	16,3	13	90
		80 B5	19	M10	43	40	165	130	200	4	6	21,8	13	100
		80 B14	19	7	43	40	100	80	120	4	6	21,8	13	100
	110	63 B5	11	M8	55	23	115	95	140	4	4	12,8	13	105
		71 B5	14	M8	55	30	130	110	160	4	5	16,3	13	105
		71 B14	14	7	55	30	85	70	105	4	5	16,3	13	105
		80 B5	19	M10	55	40	165	130	200	4	6	21,8	13	105
		80 B14	19	7	55	40	100	80	120	4	6	21,8	13	105
		134	71 B5	14	M8	67	30	130	110	160	5	5	16,3	13
	80 B5		19	M10	67	40	165	130	200	5	6	21,8	13	125
	80 B14		19	7	67	40	100	80	120	5	6	21,8	13	125
90 B5	24		M10	67	50	165	130	200	5	8	27,3	13	125	
90 B14	24		9	67	50	115	95	140	5	8	27,3	13	125	
100-112 B5	28		M12	67	60	215	180	250	5	8	31,3	13	135	
100-112 B14	28		9	67	60	130	110	160	5	8	31,3	13	135	
166	71 B5	14	9	83	30	130	110	160	6	5	16,3	15	160	
	80 B5	19	M10	83	40	165	130	200	6	6	21,8	15	160	
	90 B5	24	M10	83	50	165	130	200	6	8	27,3	15	160	
	100-112 B5	28	M12	83	60	215	180	250	6	8	31,3	15	160	
	100-112 B14	28	9	83	60	130	110	160	6	8	31,3	15	160	
200	90 B5	24	11	100	50	165	130	200	6	8	27,3	23	220	
	100-112 B5	28	M12	100	60	215	180	250	6	8	31,3	23	220	
	132 B5	38	M12	100	80	265	230	300	6	10	41,3	23	220	
	132 B14	38	11	100	80	165	130	200	6	10	41,3	23	220	
250	132 B5	38	M12	125	80	265	230	300	6	10	41,3	25	250	
	132 B14	38	11	125	80	165	130	200	6	10	41,3	25	250	
	160 B5	42	M16	125	110	300	250	350	6	12	45,8	25	250	

* XMRA: stainless steel version

For the characteristics of the shrink-disks, make reference to RA models on page 201.

For non quoted dimensions make reference to the schemes on page 201.



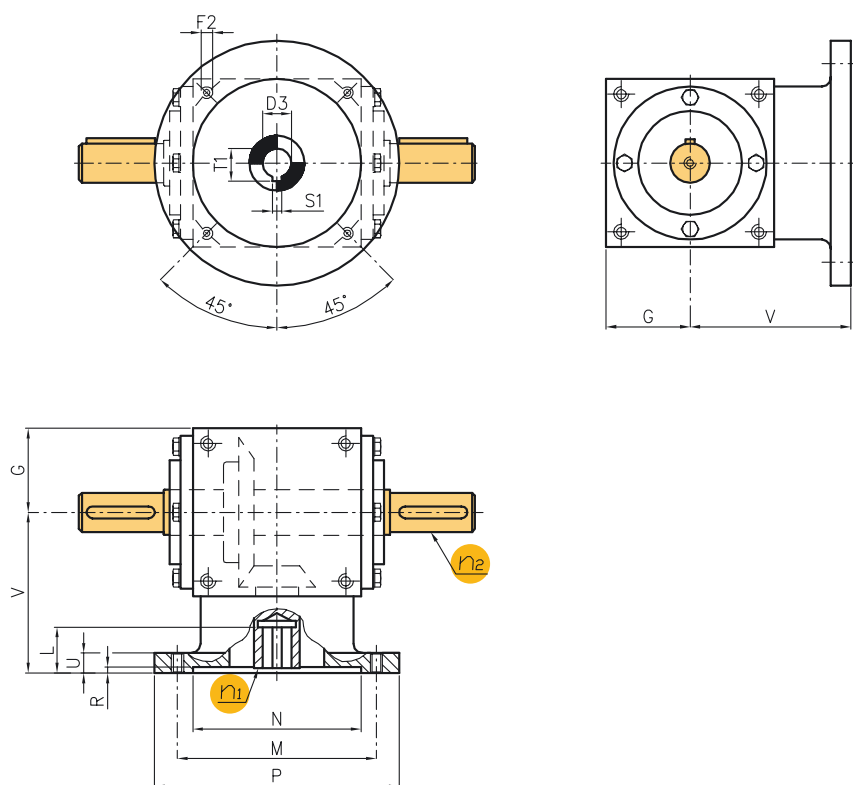

Protruding shaft motor gearbox MRS

Size	IEC flange	D3 H7	F2	G	L	M	N	P	R	S1	T1	U	V	
86	56 B5	9	M6	43	23	100	80	120	4	3	10,4	13	90	
	63 B5	11	M8	43	23	115	95	140	4	4	12,8	13	90	
	71 B5	14	M8	43	30	130	110	160	4	5	16,3	13	90	
	71 B14	14	7	43	30	85	70	105	4	5	16,3	13	90	
	80 B5	19	M10	43	40	165	130	200	4	6	21,8	13	100	
	80 B14	19	7	43	40	100	80	120	4	6	21,8	13	100	
	110	63 B5	11	M8	55	23	115	95	140	4	4	12,8	13	105
		71 B5	14	M8	55	30	130	110	160	4	5	16,3	13	105
		71 B14	14	7	55	30	85	70	105	4	5	16,3	13	105
		80 B5	19	M10	55	40	165	130	200	4	6	21,8	13	105
80 B14		19	7	55	40	100	80	120	4	6	21,8	13	105	
134	71 B5	14	M8	67	30	130	110	160	5	5	16,3	13	125	
	80 B5	19	M10	67	40	165	130	200	5	6	21,8	13	125	
	80 B14	19	7	67	40	100	80	120	5	6	21,8	13	125	
	90 B5	24	M10	67	50	165	130	200	5	8	27,3	13	125	
	90 B14	24	9	67	50	115	95	140	5	8	27,3	13	125	
	100-112 B5	28	M12	67	60	215	180	250	5	8	31,3	13	135	
	100-112 B14	28	9	67	60	130	110	160	5	8	31,3	13	135	
166	71 B5	14	9	83	30	130	110	160	6	5	16,3	15	160	
	80 B5	19	M10	83	40	165	130	200	6	6	21,8	15	160	
	90 B5	24	M10	83	50	165	130	200	6	8	27,3	15	160	
	100-112 B5	28	M12	83	60	215	180	250	6	8	31,3	15	160	
	100-112 B14	28	9	83	60	130	110	160	6	8	31,3	15	160	
200	90 B5	24	11	100	50	165	130	200	6	8	27,3	23	220	
	100-112 B5	28	M12	100	60	215	180	250	6	8	31,3	23	220	
	132 B5	38	M12	100	80	265	230	300	6	10	41,3	23	220	
250	132 B14	38	11	100	80	165	130	200	6	10	41,3	23	220	
	132 B5	38	M12	125	80	265	230	300	6	10	41,3	25	250	
	132 B14	38	11	125	80	165	130	200	6	10	41,3	25	250	
	160 B5	42	M16	125	110	300	250	350	6	12	45,8	25	250	

* XMRS: stainless steel version

For non quoted dimensions make reference to the schemes on page 202.

Basic constructive forms

ratio:
1/1



MS1



MS3



MS4

ratio:
1/1,5 - 1/2 - 1/3 - 1/4



MS2



MS9



MS10

protruding shaft motor gearboxes

Basic constructive forms

ratio:
1/1



MS31

ratio:
1/1,5 - 1/2 - 1/3 - 1/4



MS32

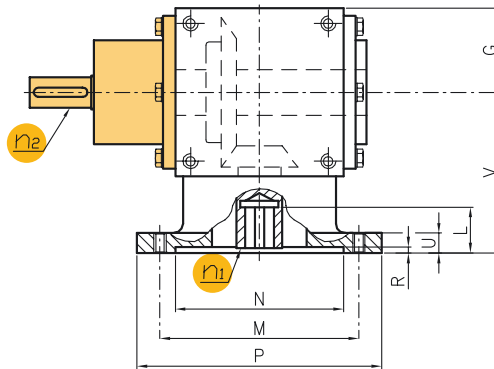
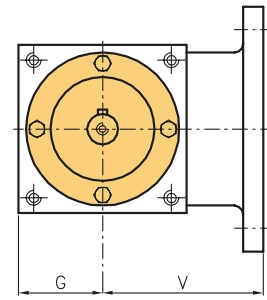
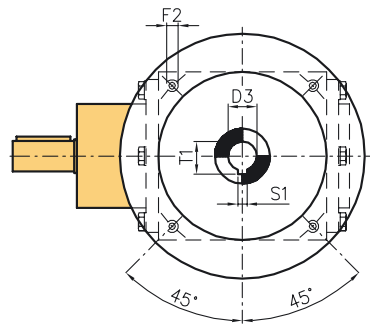

Two hubs motor gearbox MRX

Size	IEC flange	D3 H7	F2	G	L	M	N	P	R	S1	T1	U	V	
XMRX models*	86	56 B5	9	M6	43	23	100	80	120	4	3	10,4	13	90
		63 B5	11	M8	43	23	115	95	140	4	4	12,8	13	90
		71 B5	14	M8	43	30	130	110	160	4	5	16,3	13	90
		71 B14	14	7	43	30	85	70	105	4	5	16,3	13	90
		80 B5	19	M10	43	40	165	130	200	4	6	21,8	13	100
		80 B14	19	7	43	40	100	80	120	4	6	21,8	13	100
	110	63 B5	11	M8	55	23	115	95	140	4	4	12,8	13	105
		71 B5	14	M8	55	30	130	110	160	4	5	16,3	13	105
		71 B14	14	7	55	30	85	70	105	4	5	16,3	13	105
		80 B5	19	M10	55	40	165	130	200	4	6	21,8	13	105
		80 B14	19	7	55	40	100	80	120	4	6	21,8	13	105
		134	71 B5	14	M8	67	30	130	110	160	5	5	16,3	13
	80 B5		19	M10	67	40	165	130	200	5	6	21,8	13	125
	80 B14		19	7	67	40	100	80	120	5	6	21,8	13	125
	90 B5		24	M10	67	50	165	130	200	5	8	27,3	13	125
	90 B14		24	9	67	50	115	95	140	5	8	27,3	13	125
100-112 B5	28		M12	67	60	215	180	250	5	8	31,3	13	135	
166	100-112 B14	28	9	67	60	130	110	160	5	8	31,3	13	135	
	71 B5	14	9	83	30	130	110	160	6	5	16,3	15	160	
	80 B5	19	M10	83	40	165	130	200	6	6	21,8	15	160	
	90 B5	24	M10	83	50	165	130	200	6	8	27,3	15	160	
	100-112 B5	28	M12	83	60	215	180	250	6	8	31,3	15	160	
200	100-112 B14	28	9	83	60	130	110	160	6	8	31,3	15	160	
	90 B5	24	11	100	50	165	130	200	6	8	27,3	23	220	
	100-112 B5	28	M12	100	60	215	180	250	6	8	31,3	23	220	
	132 B5	38	M12	100	80	265	230	300	6	10	41,3	23	220	
250	132 B14	38	11	100	80	165	130	200	6	10	41,3	23	220	
	132 B5	38	M12	125	80	265	230	300	6	10	41,3	25	250	
	132 B14	38	11	125	80	165	130	200	6	10	41,3	25	250	
	160 B5	42	M16	125	110	300	250	350	6	12	45,8	25	250	

* XMRX: stainless steel version

For non quoted dimensions make reference to the schemes on page 204.



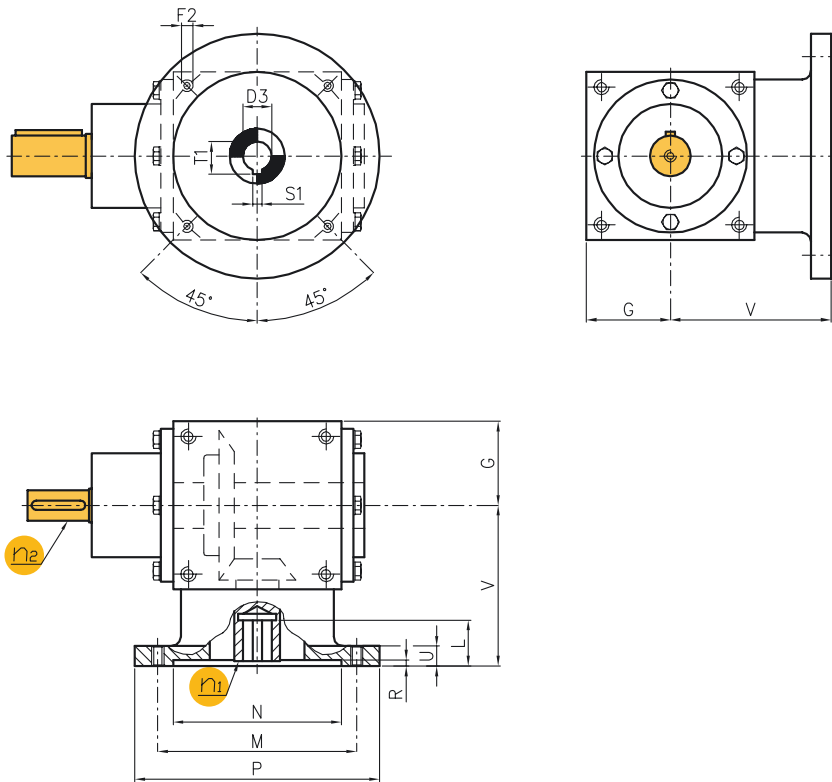

Basic constructive forms

ratio:
1/1



MS31

ratio:

1/1,5 - 1/2 - 1/3 - 1/4



MS32

Two hubs motor gearbox with reinforced shafts MRZ

Size	IEC flange	D3 H7	F2	G	L	M	N	P	R	S1	T1	U	V	
XMRZ models*	86	56 B5	9	M6	43	23	100	80	120	4	3	10,4	13	90
		63 B5	11	M8	43	23	115	95	140	4	4	12,8	13	90
		71 B5	14	M8	43	30	130	110	160	4	5	16,3	13	90
		71 B14	14	7	43	30	85	70	105	4	5	16,3	13	90
		80 B5	19	M10	43	40	165	130	200	4	6	21,8	13	100
		80 B14	19	7	43	40	100	80	120	4	6	21,8	13	100
	110	63 B5	11	M8	55	23	115	95	140	4	4	12,8	13	105
		71 B5	14	M8	55	30	130	110	160	4	5	16,3	13	105
		71 B14	14	7	55	30	85	70	105	4	5	16,3	13	105
		80 B5	19	M10	55	40	165	130	200	4	6	21,8	13	105
		80 B14	19	7	55	40	100	80	120	4	6	21,8	13	105
	134	71 B5	14	M8	67	30	130	110	160	5	5	16,3	13	125
		80 B5	19	M10	67	40	165	130	200	5	6	21,8	13	125
		80 B14	19	7	67	40	100	80	120	5	6	21,8	13	125
90 B5		24	M10	67	50	165	130	200	5	8	27,3	13	125	
90 B14		24	9	67	50	115	95	140	5	8	27,3	13	125	
100-112 B5		28	M12	67	60	215	180	250	5	8	31,3	13	135	
100-112 B14		28	9	67	60	130	110	160	5	8	31,3	13	135	
166	71 B5	14	9	83	30	130	110	160	6	5	16,3	15	160	
	80 B5	19	M10	83	40	165	130	200	6	6	21,8	15	160	
	90 B5	24	M10	83	50	165	130	200	6	8	27,3	15	160	
	100-112 B5	28	M12	83	60	215	180	250	6	8	31,3	15	160	
	100-112 B14	28	9	83	60	130	110	160	6	8	31,3	15	160	
200	90 B5	24	11	100	50	165	130	200	6	8	27,3	23	220	
	100-112 B5	28	M12	100	60	215	180	250	6	8	31,3	23	220	
	132 B5	38	M12	100	80	265	230	300	6	10	41,3	23	220	
	132 B14	38	11	100	80	165	130	200	6	10	41,3	23	220	
250	132 B5	38	M12	125	80	265	230	300	6	10	41,3	25	250	
	132 B14	38	11	125	80	165	130	200	6	10	41,3	25	250	
	160 B5	42	M16	125	110	300	250	350	6	12	45,8	25	250	

* XMRZ: stainless steel version

For non quoted dimensions make reference to the schemes on page 205.

ratio:
1/4,5 - 1/6 - 1/9 - 1/12

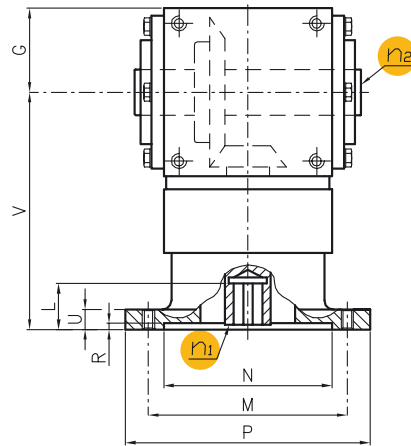
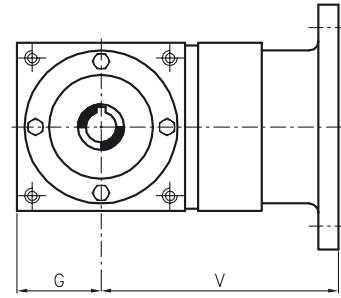
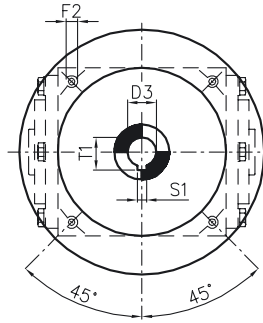

High reduction motor gearbox with hollow shaft MREC
High reduction motor gearbox with broached hollow shaft MREB
High reduction motor gearbox with hollow shaft with shrink-disks MREA
High reduction motor gearbox with protruding shaft MRES

Size	IEC flange	D3 H7	F2	G	L	M	N	P	R	S1	T1	U	V
32	71 B5	14	M8	67	30	130	110	160	5	5	16,3	13	213
	80 B5	19	M10	67	40	165	130	200	5	6	21,8	13	213
	80 B14	19	7	67	40	100	80	120	5	6	21,8	13	213
	90 B5	24	M10	67	50	165	130	200	5	8	27,3	13	213
	90 B14	24	9	67	50	115	95	140	5	8	27,3	13	213
	100-112 B5	28	M12	67	60	215	180	250	5	8	31,3	13	223
42	100-112 B14	28	9	67	60	130	110	160	5	8	31,3	13	223
	71 B5	14	9	83	30	130	110	160	6	5	16,3	15	258
	80 B5	19	M10	83	40	165	130	200	6	6	21,8	15	258
	90 B5	24	M10	83	50	165	130	200	6	8	27,3	15	258
	100-112 B5	28	M12	83	60	215	180	250	6	8	31,3	15	258
55	100-112 B14	28	9	83	60	130	110	160	6	8	31,3	15	258
	90B5	24	11	100	50	165	130	200	6	8	27,3	23	348
	100-112 B5	28	M12	100	60	215	180	250	6	8	31,3	23	348
	132 B5	38	M12	100	80	265	230	300	6	10	41,3	23	348
	132 B14	38	11	100	80	165	130	200	6	10	41,3	23	348

For non quoted dimensions make reference to the schemes on page 208-211.



CONSTRUCTIVE FORMS

For every mounting scheme it is possible to apply a motor flange in the positions indicated under letter m.
Order example:

- For a C3 mounting scheme and a m² flange: C3/m2

RC - RR - RB - RA

ratio:
1/1

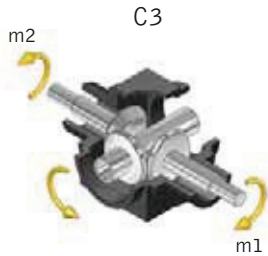

RS - RP

ratio:
1/1

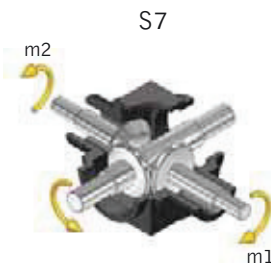
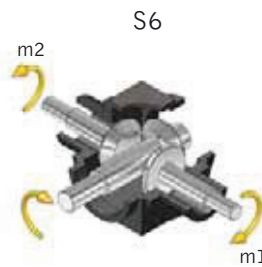
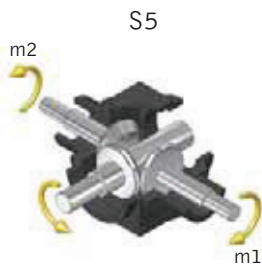

RX - RZ

ratio:
1/1

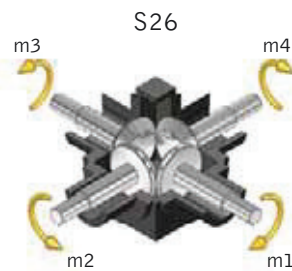
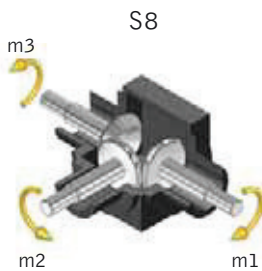

RC - RB - RA

ratio:
1/1,5 - 1/2 - 1/3 - 1/4

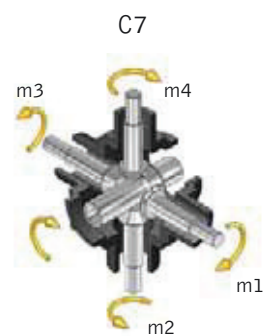
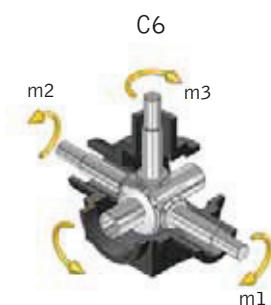
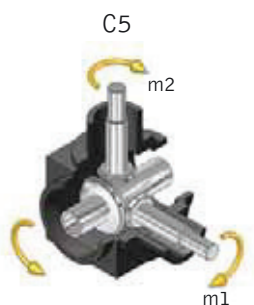
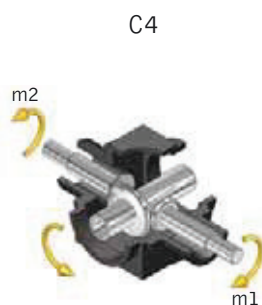

S11

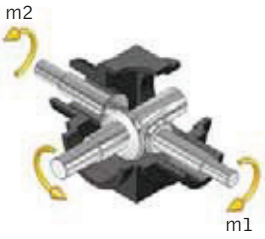

S12

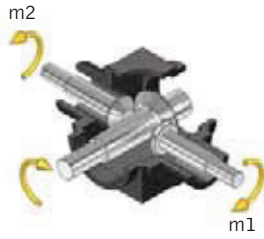

S13

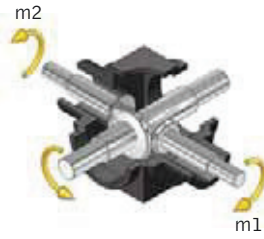

S15

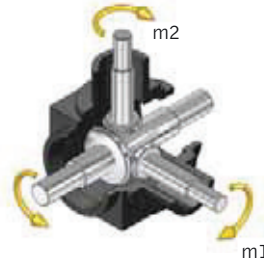

RS - RP

ratio:
1/1,5 - 1/2 - 1/3 - 1/4

S16

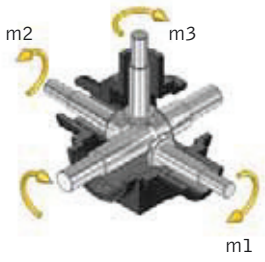

S17

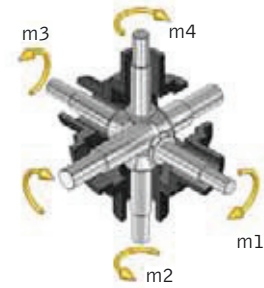

S18

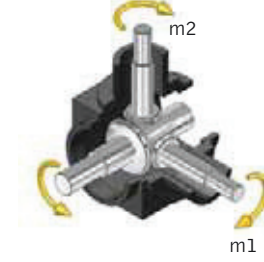

S19

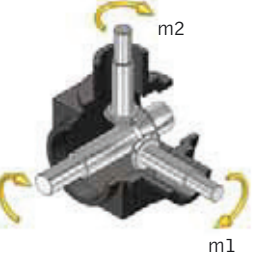

S20

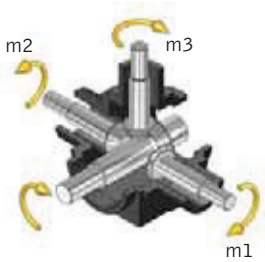

S21

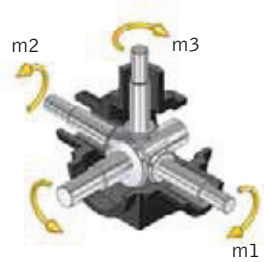

S22

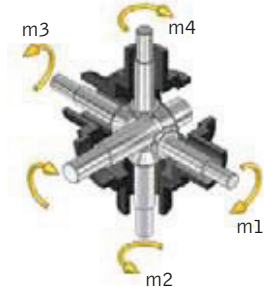

S23

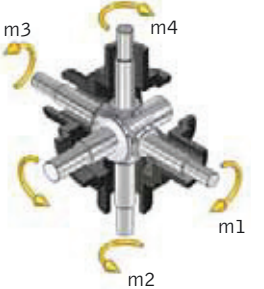

S14

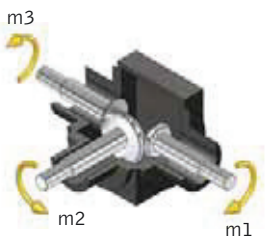

S27

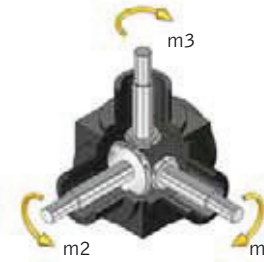

S28

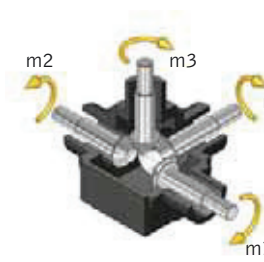

RX - RZ

ratio:
1/1,5 - 1/2 - 1/3 - 1/4

S29

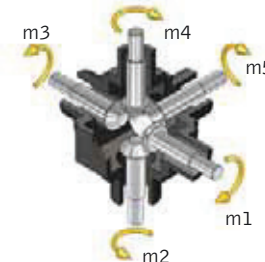

S30

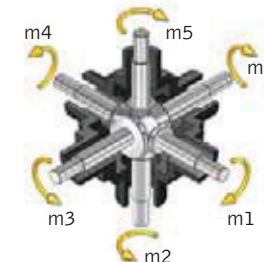

S33

