

<b>Indice</b>	<b>IT</b>
Simbologia .....	3
Omologazione .....	3
Funzionamento .....	5
Scelta del variatore .....	6
Fattore di servizio .....	8
Applicazioni critiche .....	10
Installazione .....	12
Carichi radiali .....	14
Lubrificazione .....	18
Finitura superficiale .....	23
<b>TXF/S</b>	
Designazione .....	26
Versione .....	28
Piazzamento .....	29
Prestazioni TXF .....	30
Dimensioni TXF .....	34
Prestazioni S .....	35
Dimensioni S .....	40
Motori elettrici .....	45
Accessori .....	46
<b>VH/VHA</b>	
Designazione .....	52
Versione .....	53
Piazzamento .....	54
Combinazioni VHA .....	56
Prestazioni VHA .....	57
Dimensioni VHA .....	68
Combinazioni VH .....	72
Prestazioni VH .....	73
Dimensioni VH .....	106
Accessori .....	112
<b>TXF/S+NMRV</b>	
Designazione .....	116
Versione .....	117
Piazzamento .....	118
Combinazioni TXF+NMRV .....	121
Prestazioni TXF+NMRV .....	122
Dimensioni TXF+NMRV .....	132
Combinazioni S+NMRV .....	134
Prestazioni S+NMRV .....	135
Dimensioni S+NMRV .....	142
Accessori .....	143
Condizioni di vendita .....	146

<b>Contents</b>	<b>UK</b>
Symbols .....	3
Specification .....	3
Running .....	5
Choosing a variator .....	6
Service factor .....	8
Critical applications .....	10
Installation .....	12
Radial loads .....	14
Lubrication .....	18
Surface treatment specifications .....	23
<b>TXF/S</b>	
Designation .....	26
Versions .....	28
Mounting positions .....	29
Performance TXF .....	30
Dimensions TXF .....	34
Performance S .....	35
Dimensions S .....	40
Electric motors .....	45
Accessories .....	46
<b>VH/VHA</b>	
Designation .....	52
Versions .....	53
Mounting positions .....	54
Combinations VHA .....	56
Performance VHA .....	57
Dimensions VHA .....	68
Combinations VH .....	72
Performance VH .....	73
Dimensions VH .....	106
Accessories .....	112
<b>TXF/S+NMRV</b>	
Designation .....	116
Versions .....	117
Mounting positions .....	118
Combinations TXF+NMRV .....	121
Performance TXF+NMRV .....	122
Dimensions TXF+NMRV .....	132
Combinations S+NMRV .....	134
Performance S+NMRV .....	135
Dimensions S+NMRV .....	142
Accessories .....	143
Sales conditions .....	146

<b>Index</b>	<b>FR</b>
Symboles .....	3
Homologation .....	3
Fonctionnement .....	5
Choix du type de variateur .....	6
Facteur de service .....	8
Applications critiques .....	10
Installation .....	12
Charges radiales .....	14
Lubrification .....	18
Spécifications sur l'aspect extérieur .....	23
<b>TXF/S</b>	
Désignation .....	26
Versions .....	28
Positions de montage .....	29
Performances TXF .....	30
Encombrements TXF .....	34
Performances S .....	35
Encombrements S .....	40
Moteurs électriques .....	45
Accessoires .....	46
<b>VH/VHA</b>	
Désignation .....	52
Versions .....	53
Positions de montage .....	54
Combinaisons VHA .....	56
Performances VHA .....	57
Encombrements VHA .....	68
Combinaisons VH .....	72
Performances VH .....	73
Encombrements VH .....	106
Accessoires .....	112
<b>TXF/S+NMRV</b>	
Désignation .....	116
Versions .....	117
Positions de montage .....	118
Combinaisons TXF+NMRV .....	121
Performances TXF+NMRV .....	122
Encombrements TXF+NMRV .....	132
Combinaisons S+NMRV .....	134
Performances S+NMRV .....	135
Encombrements S+NMRV .....	142
Accessoires .....	143
Conditions de vente .....	146

# TXF/S

Motovariatori  
Motovariators  
Motovariateurs  
Verstellgetriebemotoren  
Motovariadores  
电机变速器

TXF/S

**TXF**

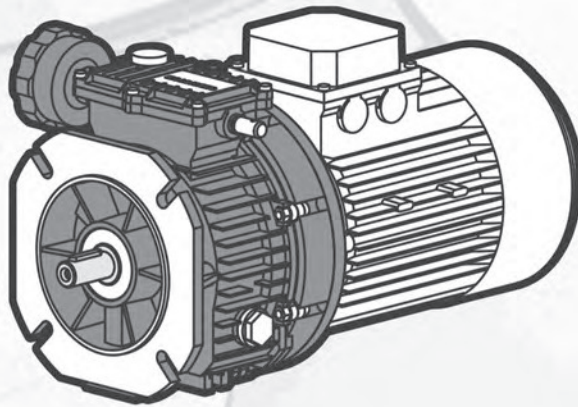

**S**

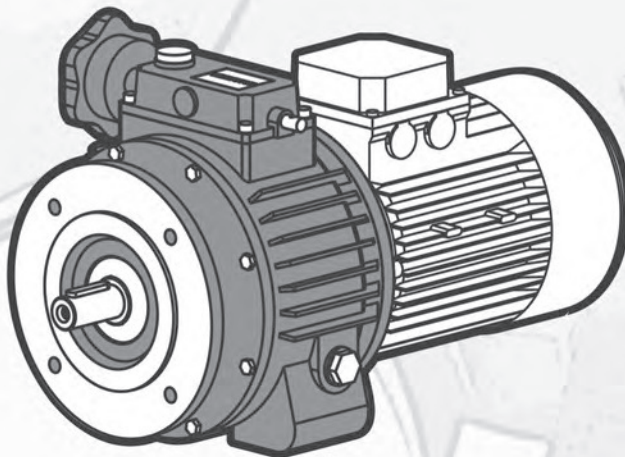

**S - Designazione / Designation / Désignation /  
Bezeichnung / Designación / 名称**

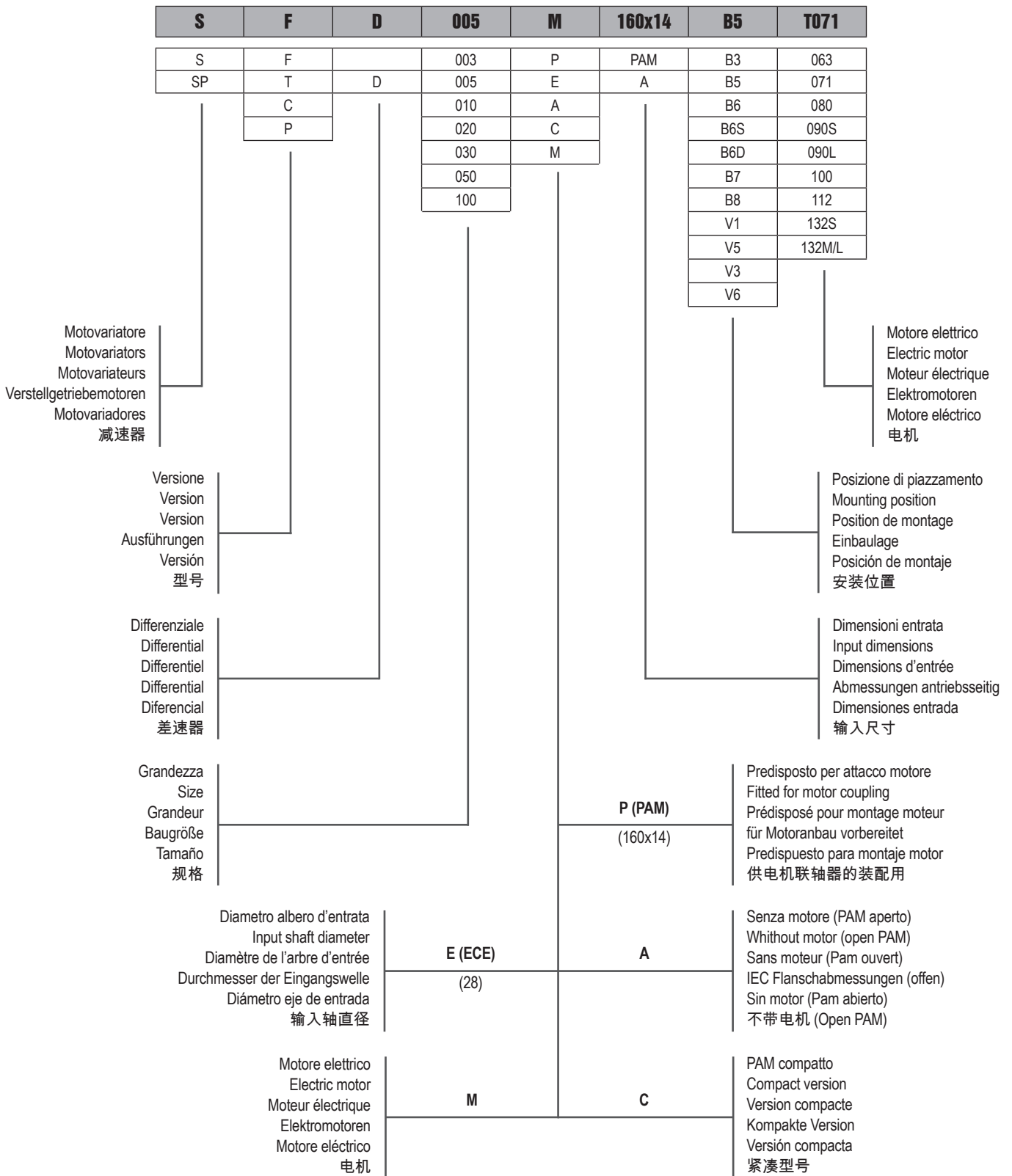

**TXF - Designazione / Designation / Désignation /  
Bezeichnung / Designación / 名称**

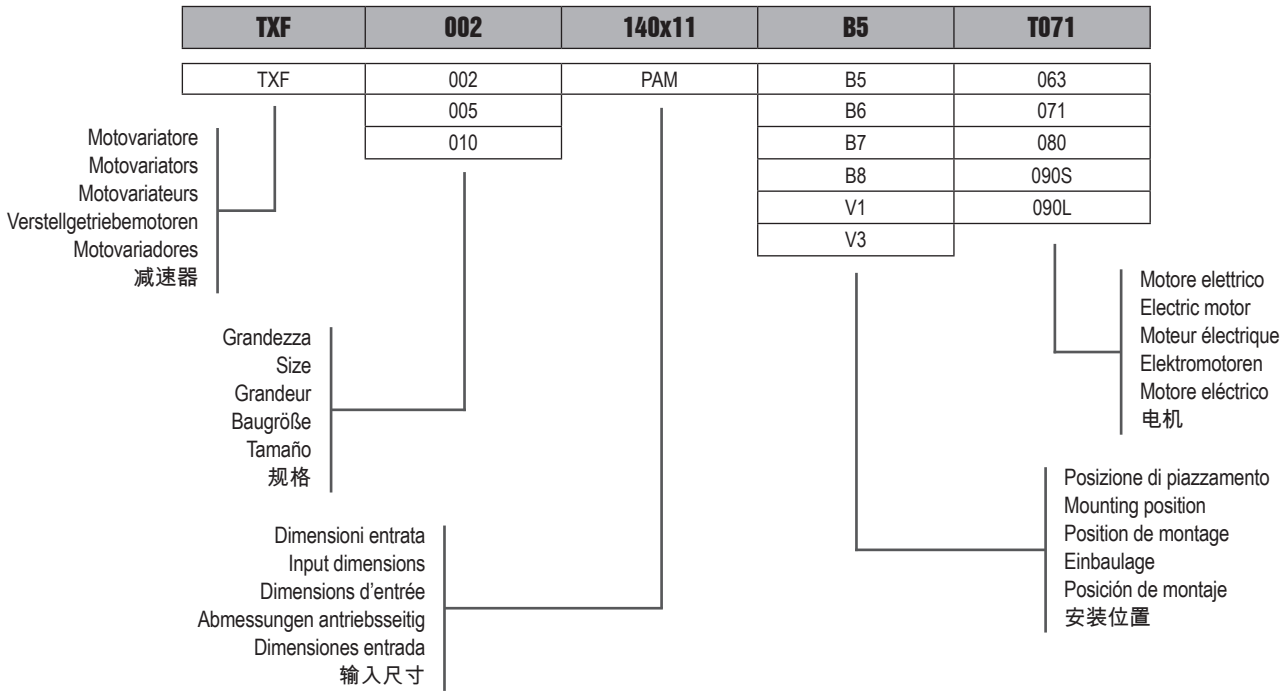

**T - Designazione / Designation / Désignation /  
Bezeichnung / Designación / 名称**

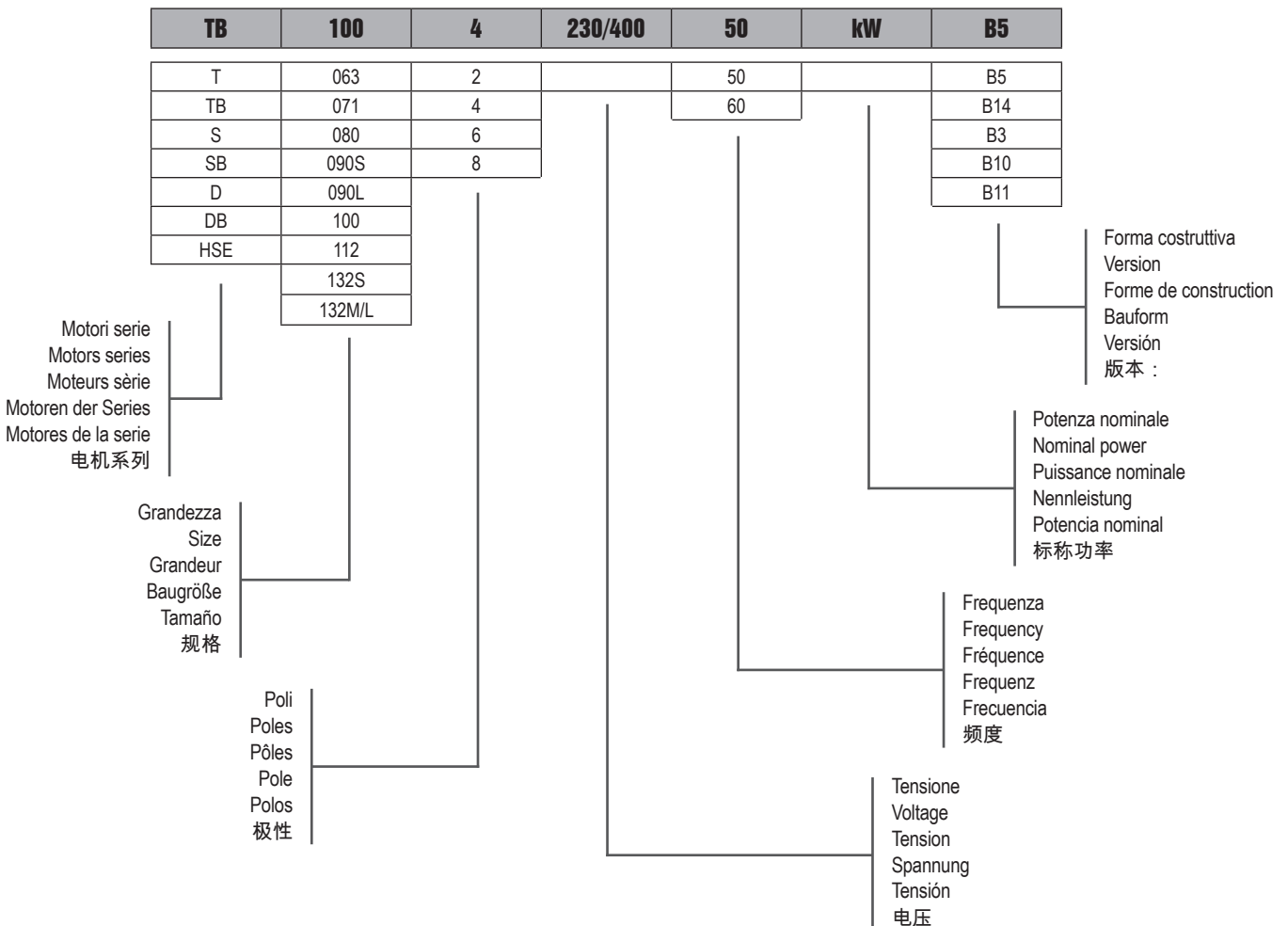

**Versioni / Versions / Versions /  
Ausführungen / Versiones / 版本**

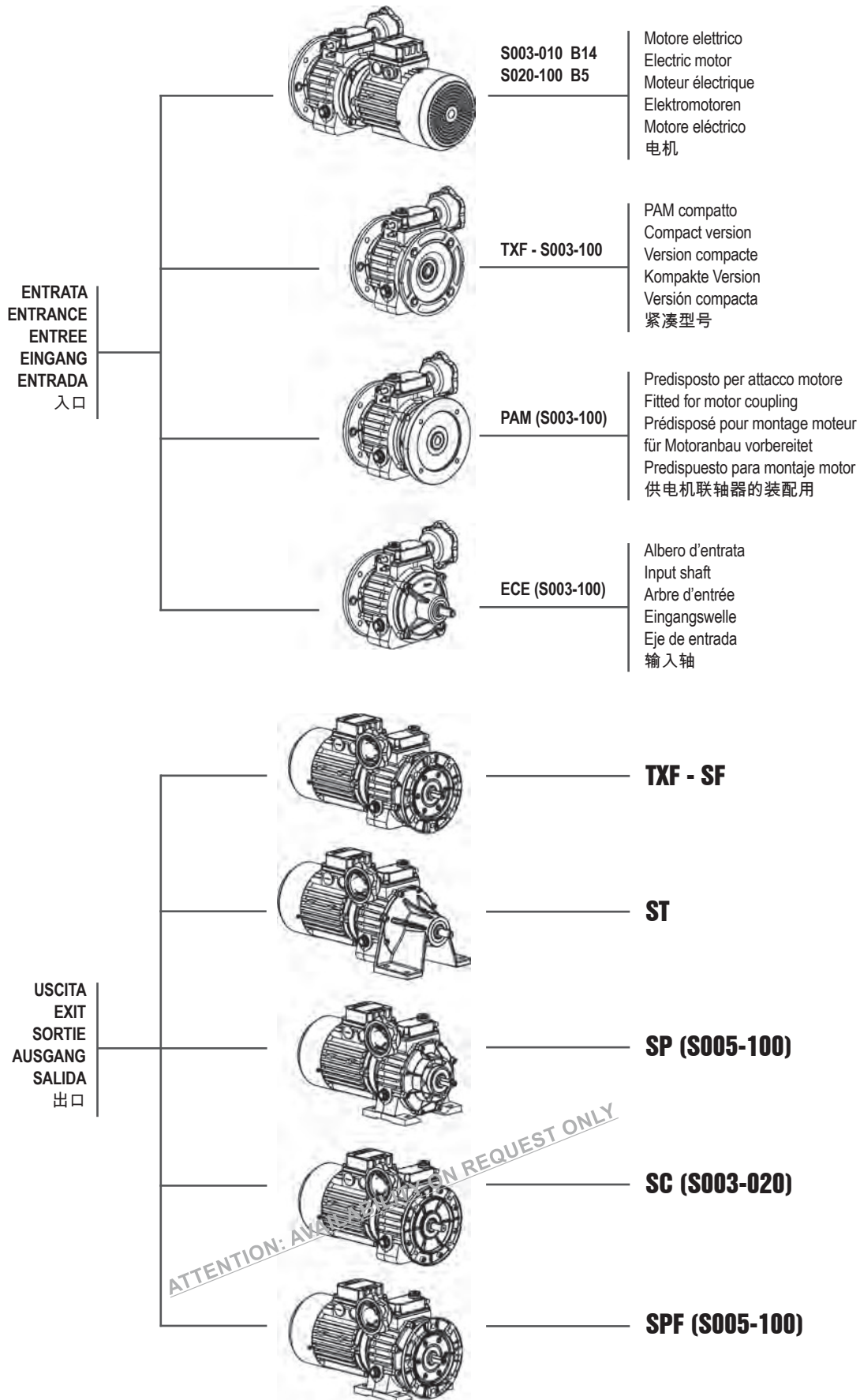

ATTENTION: AVAILABLE ON REQUEST ONLY



**TXF/S - Piazzamento / Mounting positions / Pos. de montage /  
Einbaulage / Pos. de montaje / 安装位置**

**TXF**

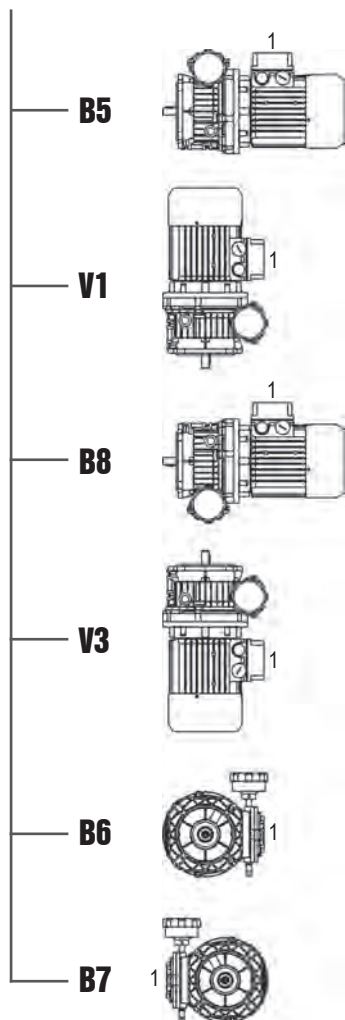

**SF**

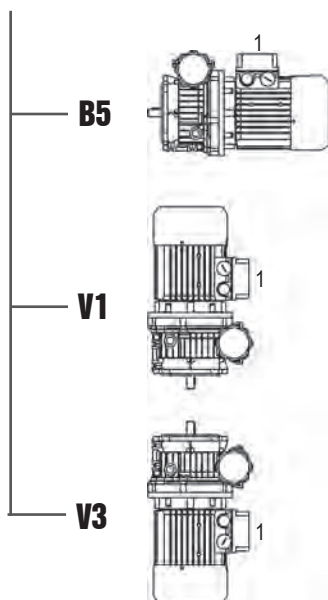

**ST**

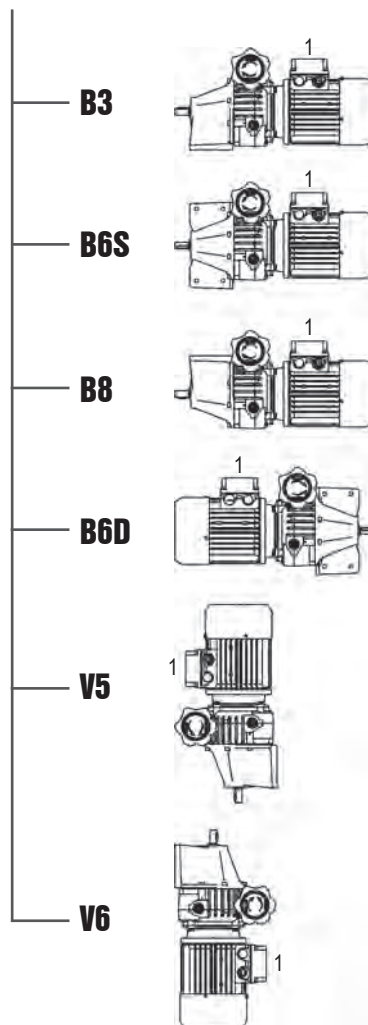

**Volantino di comando / Control handwheel /  
Volant de commande / Steuer-Handräd  
Volante de mando / 控制旋牛**

**Posizione morsettiera / Position of terminal box /  
Position du bornier / Klemmenkastenlage /  
Posición caja de bornes / 接线盒位置**

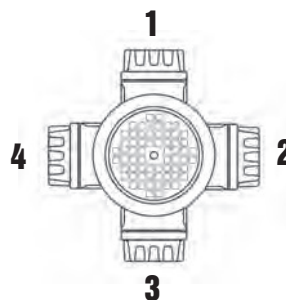
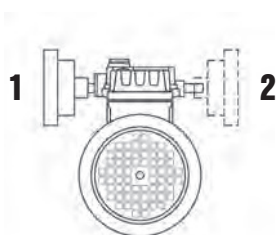

- Posizione morsettiera, se non diversamente specificato, il gruppo viene fornito con morsettiera in pos. 1.
- Position of terminal box, unless otherwise specified, the gear reducer is supplied with terminal box in position 1.
- Position du bornier, sauf indications contraires, le réducteur est fourni avec boîte à borne en position 1.
- Klemmenkastenlage, Sofern nichts gegenteiliges angegeben, wird der Schneckengetriebemotor mit Klemmkastenlage 1 geliefert.
- Posición caja de bornes, si no esta diferentemente especificado, el motorreductor se monta con la caja de bornes en posición 1.
- 接线盒位置, 除非另有规定, 齿轮变速器都配供有 1 号位接线盒。

**TXF - Prestazioni / Performance / Performances /  
 Leistungen / Prestaciones / 性能**

P1 (kW)			n1 1/min	n2 (a) 1/min	n2 (b) 1/min	M2 (a) Nm	M2 (b) Nm	Fr2 (a) N	Fr2 (b) N
<b>0,15</b>	TXF002	63C6	900	566	109	2,1	4	320	550
<b>0,22</b>	TXF002	63C4	1400	880	170	2	4	270	480
<b>0,25</b>	TXF005	71A4	1400	1000	170	2	6	580	1050
	TXF005	71B6	900	643	109	3	6	670	1050
<b>0,37</b>	TXF002	63C2	2800	1760	340	1,7	4	220	380
	TXF005	71B4	1400	1000	170	3	6	580	1050
<b>0,55</b>	TXF005	71B2	2800	2000	340	2,2	6	460	800
	TXF005	71C4	1400	1000	170	4,4	6	580	1050
	TXF005	80A4	1400	950	270	4,6	6	590	900
	TXF005	80B6	900	611	174	6	6	680	1050
	TXF010	80A4	1400	1000	170	4,4	12	650	1150
	TXF010	80B6	900	643	109	6,6	12	750	1350
<b>0,75</b>	TXF005	71C2	2800	2000	340	3	6	460	800
	TXF005	80A2	2800	1900	540	3,2	6	480	710
	TXF005	80B4	1400	950	270	6	6	590	900
	TXF010	80B4	1400	1000	170	6	12	650	1150
	TXF010	90S6	900	611	174	9,5	12	760	1140
<b>0,92</b>	TXF010	80C4	1400	1000	170	7,2	12	650	1150
<b>1,1</b>	TXF005	80B2	2800	1900	540	4,7	6	480	710
	TXF010	80B2	2800	2000	340	4,4	12	510	930
	TXF010	90S4	1400	950	270	9,1	12	660	900
<b>1,5</b>	TXF005	80C2	2800	1900	540	6	6	480	710
	TXF010	80C2	2800	2000	340	6	12	510	930
	TXF010	90S2	2800	1900	540	6,3	12	520	790
	TXF010	90L4	1400	950	270	12	12	660	900
<b>2,2</b>	TXF010	90L2	2800	1900	540	9,3	12	480	710

- (a) Valori relativi alla velocità max.  
 (a) Values relating to maximum speed  
 (a) Valeurs relatifs au vitesse maximum  
 (a) Angaben im oberen Drehzahlbereich  
 (a) Valores relativos a la velocidad máxima  
 (a) 与最大速度有关的数值

- (b) Valori relativi alla velocità min.  
 (b) Values relating to minimum speed  
 (b) Valeurs relatifs au vitesse minimum  
 (b) Angaben im unteren Drehzahlbereich  
 (b) Valores relativos a la velocidad mínima  
 (b) 与最小速度有关的数值

**TXF - Curve prestazioni / Performance curves / Courbes de performances /  
Leistungskurven / Curvas de prestaciones / 性能曲线**

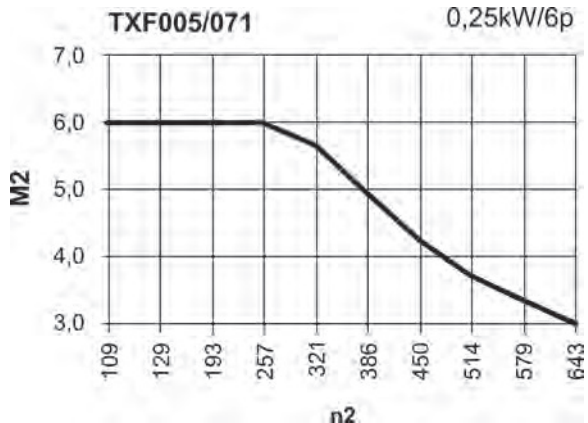
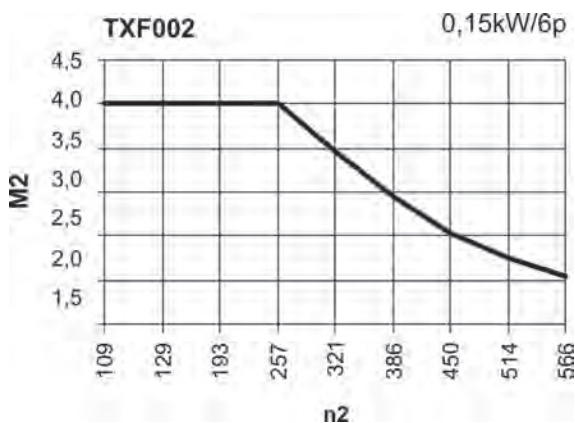
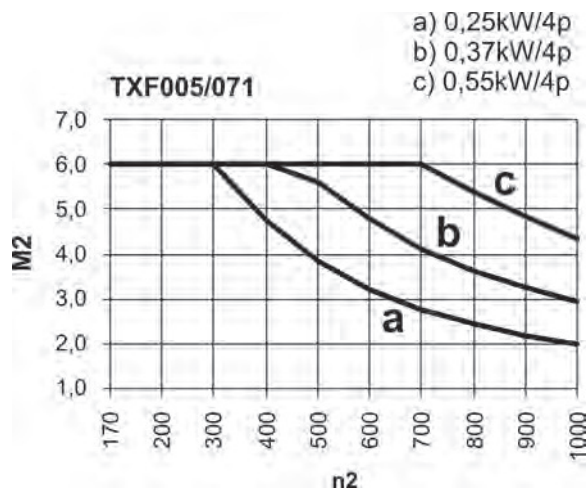
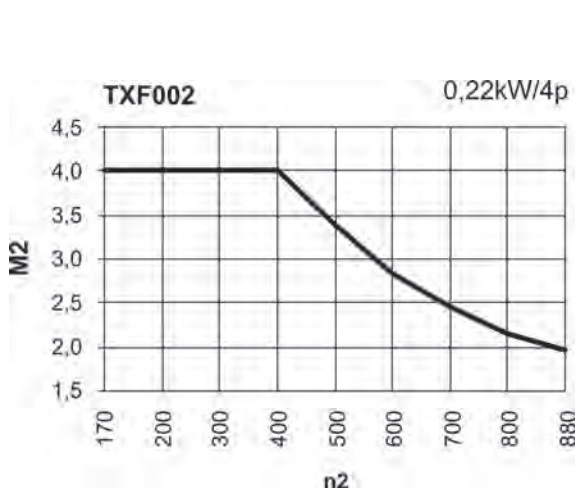
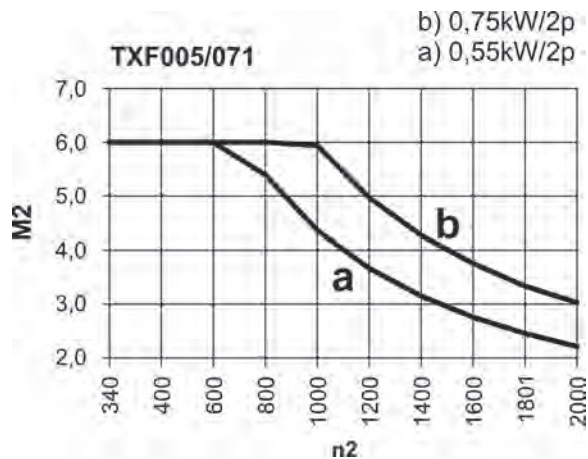
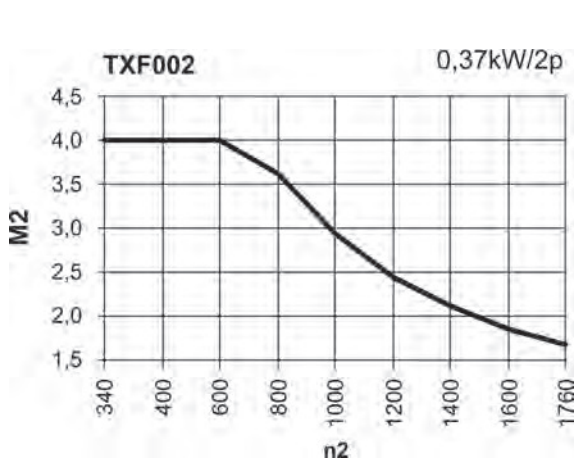



**TXF - Curve prestazioni / Performance curves / Courbes de performances / Leistungskurven / Curvas de prestaciones / 性能曲线**

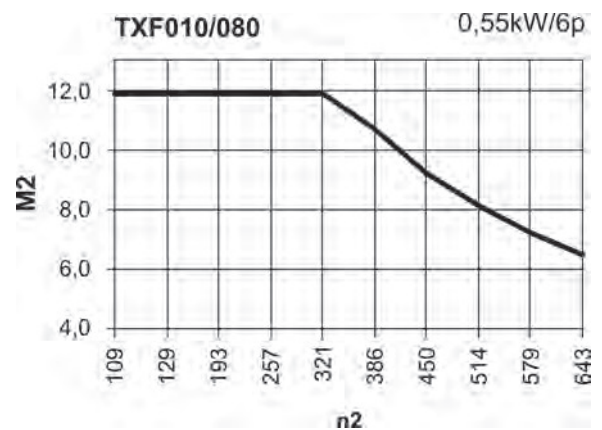
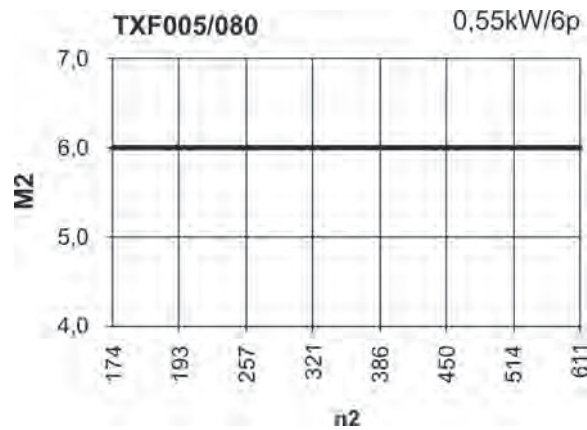
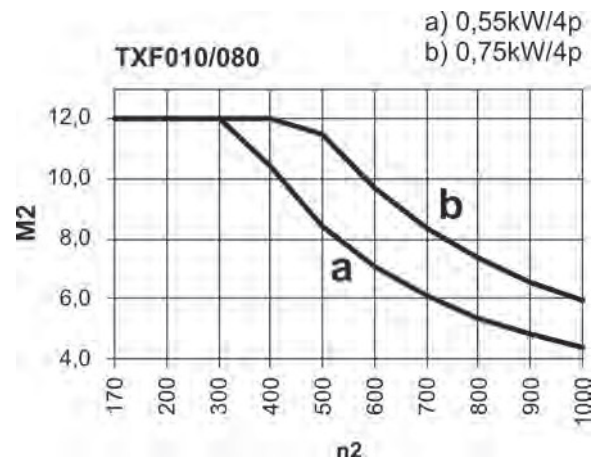
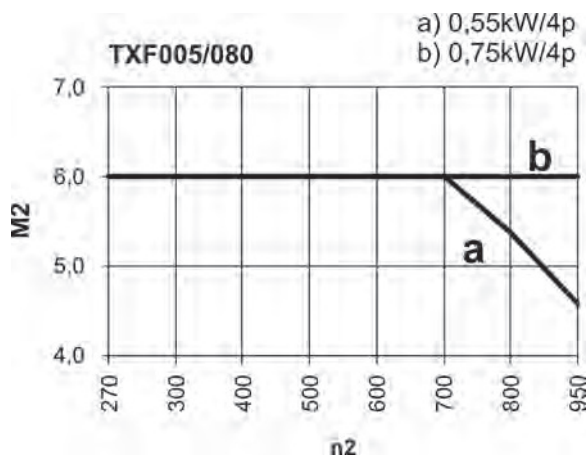
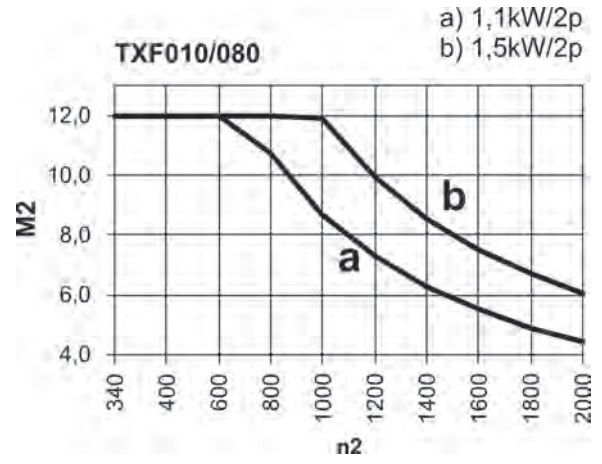
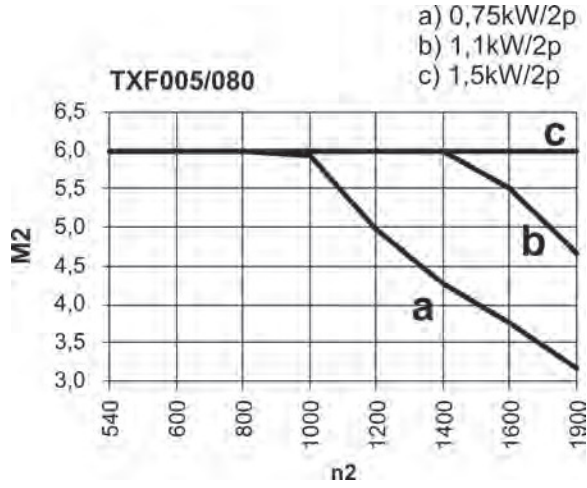

**TXF - Curve prestazioni / Performance curves / Courbes de performances / Leistungskurven / Curvas de prestaciones / 性能曲线**

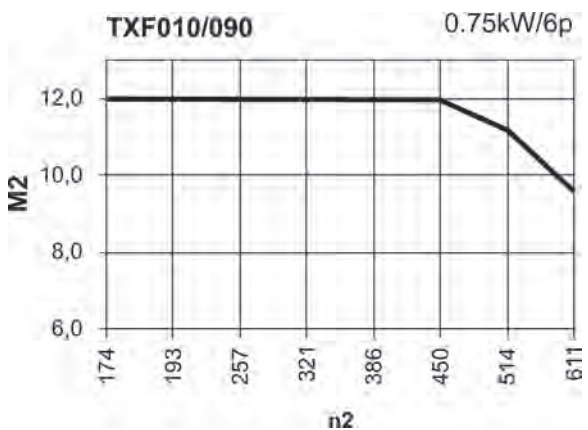
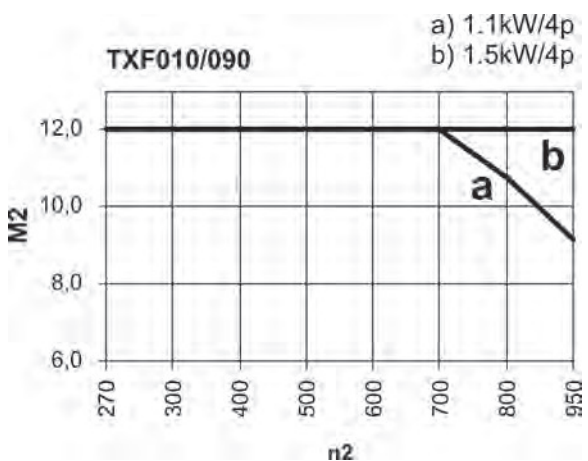
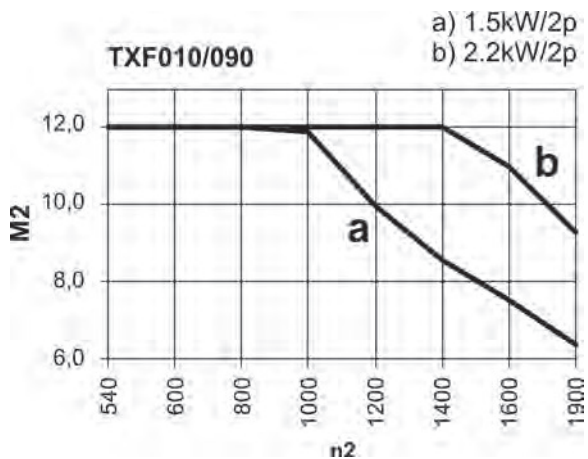

**TXF - Dimensioni / Dimensions / Encombremets /  
Abmessungen / Dimensiones / 尺寸**

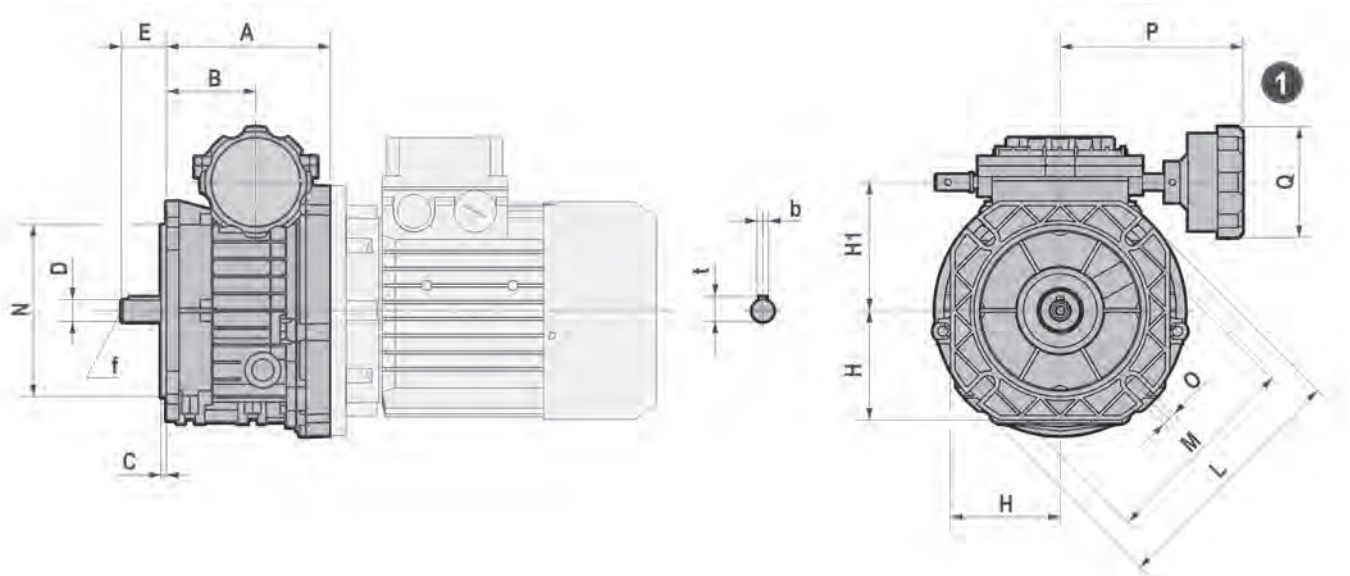

	<b>A</b>	<b>B</b>	<b>C</b>	<b>D j6</b>	<b>E</b>	<b>H</b>	<b>H1</b>	<b>L</b>	<b>M</b>
<b>002/063</b>	82,5	40	3	11 (14)	23 (30)	62,5	69	140	115
<b>005/071</b>	103,5	57	3,5	14 (19)	30 (40)	70	82	160	130
<b>005/080</b>	114,5	57	3,5	14 (19)	30 (40)	70	82	160	130
<b>010/080</b>	131,5	68,5	3,5	19 (24)	40 (50)	90	103	200	165
<b>010/090</b>	131,5	68,5	3,5	19 (24)	40 (50)	90	103	200	165

	<b>N f8</b>	<b>O</b>	<b>P</b>	<b>Q</b>	<b>b</b>	<b>t</b>	<b>f</b>	<b>Kg</b>
<b>002/063</b>	95	9	116,5	71	4 (5)	12,5 (16)	- (M6)	2,3
<b>005/071</b>	110	9	116,5	71	5 (6)	16 (21.5)	M6 (M6)	3,3
<b>005/080</b>	110	9	116,5	71	5 (6)	16 (21.5)	M6 (M6)	4
<b>010/080</b>	130	11	126,5	71	6 (8)	21,5 (27)	M6 (M8)	6,1
<b>010/090</b>	130	11	126,5	71	6 (8)	21,5 (27)	M6 (M8)	6,7

- Peso senza motore
- Weight without motor
- Poids sans moteur
- Gewicht ohne Motor
- Peso sin motor
- 重量 (不含电机)

- (..) Solo su richiesta
- (..) Only on request
- (..) Seulement sur demande
- (..) Auf Wunsch
- (..) Sólo bajo pedido
- (..) 仅仅根据需要提供

## S - Prestazioni / Performance / Performances / Leistungen / Prestaciones / 性能

MOTOVARIATORI / MOTOVARIATOR / MOTOVARIATEUR /  
VERSTELLGETRIEBE / VARIADOR DE VELOCIDAD / 电机变速器

DIFFERENZIALE / DIFFERENTIAL / DIFFERENTIEL /  
DIFFERENTIAL / DIFERENCIAL / 差速器

P1 (kW)			n1 1/min	n2 (a) 1/min	n2 (b) 1/min	M2 (a) Nm	M2 (b) Nm	Fr2 (a) N	Fr2 (b) N		n2 max 1/min	n2 min 1/min	M2 max Nm
0,15	S003	63C6	900	620	125	2,1	4	500	700	-	-	-	-
0,22	S003	63C4	1400	950	190	2	4	440	760	-	-	-	-
0,25	S005	71A4	1400	950	190	2	6	802	1120	-	-	-	-
	S005	71B6	900	610	122	3	6	930	1120	SD005	610	0	6
0,37	S003	63C2	2800	1900	380	1,7	4	340	670	-	-	-	-
	S005	71B4	1400	950	190	3	6	810	1120	SD005	950	0	6
0,55	S005	71B2	2800	1900	380	2,2	6	640	1120	SD005	1900	0	6
	S005	71C4	1400	950	190	4,4	6	720	1120	SD005	950	0	6
	S010	80A4	1400	950	190	4,4	12	930	1910	-	-	-	-
	S010	80B6	900	610	122	6,6	12	1080	1910	SD010	610	0	12
0,75	S005	71C2	2800	1900	380	3	6	640	1120	SD005	1900	0	6
	S010	80B4	1400	950	190	6	12	940	1640	SD010	950	0	12
0,92	S010	80C4	1400	950	190	7,5	12	870	1640	SD010	950	0	12
1,10	S010	80B2	2800	1900	380	4,4	12	740	1300	SD010	1900	0	12
	S020	90S4	1400	1000	190	9	24	1130	1960	SD020	1000	0	24
	S020	90L6	900	660	122	13,5	24	1300	2290	SD020	660	0	24
1,50	S010	80C2	2800	1900	380	6	12	740	1300	SD010	1900	0	12
	S020	90S2	2800	2000	380	6	24	890	1560	SD020	2000	0	24
	S020	90L4	1400	1000	190	12	24	1130	1960	SD020	1000	0	24
	S030	100LA6	900	660	122	18	48	2570	4540	SD030	660	0	48
1,84	S020	90LL4	1400	1000	190	15	24	1050	1960	SD020	1000	0	24
2,20	S020	90L2	2800	2000	380	9	24	890	1560	SD020	2000	0	24
	S030	100LA4	1400	1000	190	18	48	2240	3890	SD030	1000	0	48
	S050	112M6	900	660	122	27	64	2570	4540	SD050	660	0	64
3,00	S030	100LB4	1400	1000	190	24	48	2240	3890	SD030	1000	0	48
4,00	S050	112M4	1400	1000	190	32	64	2240	3890	SD050	1000	0	64
4,80	S050	112MS4	1400	1000	190	40	64	2010	3890	SD050	1000	0	64
5,50	S100	132S4	1400	1000	190	44	144	2900	5050	SD100	1000	0	144
	S100	132M6	900	660	122	66	144	3330	5890	SD100	660	0	144
7,50	S100	132L4	1400	1000	190	60	144	2900	5050	SD100	1000	0	144
9,20	S100	132M4	1400	1000	190	74	144	2900	5050	SD100	1000	0	144

- (a) Valori relativi alla velocità max.  
(a) Values relating to maximum speed  
(a) Valeurs relatifs au vitesse maximum  
(a) Angaben im oberen Drehzahlbereich  
(a) Valores relativos a la velocidad máxima  
(a) 与最大速度有关的数值
- (b) Valori relativi alla velocità min.  
(b) Values relating to minium speed  
(b) Valeurs relatifs au vitesse minimum  
(b) Angaben im unteren Drehzahlbereich  
(b) Valores relativos a la velocidad mínima  
(b) 与最小速度有关的数值



**S - Curve prestazioni / Performance curves / Courbes de performances / Leistungskurven / Curvas de prestaciones / 性能曲线**

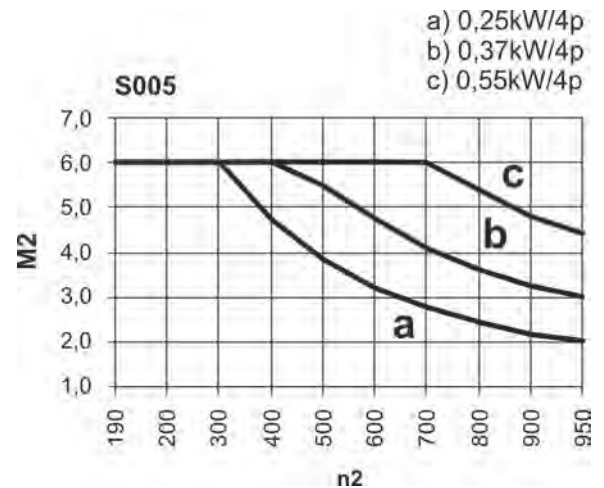
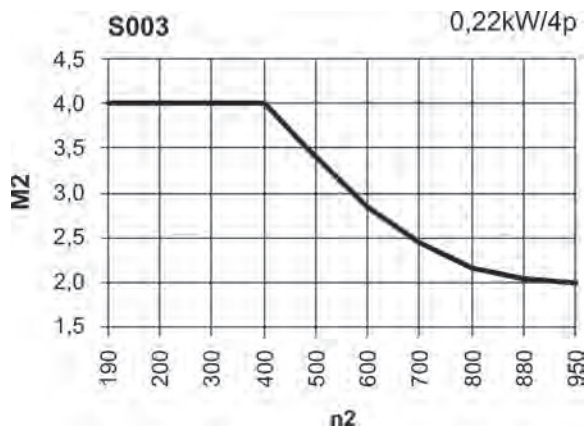
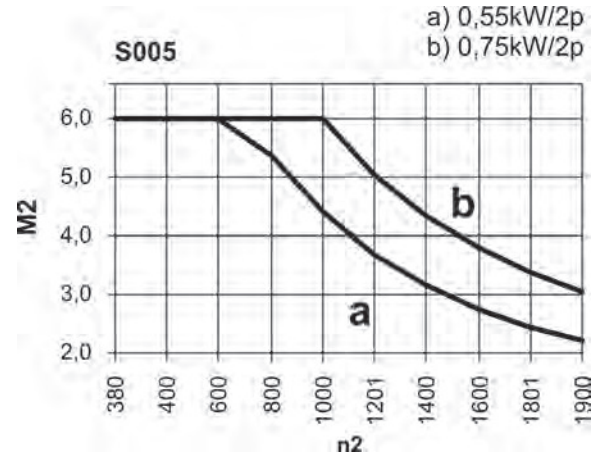
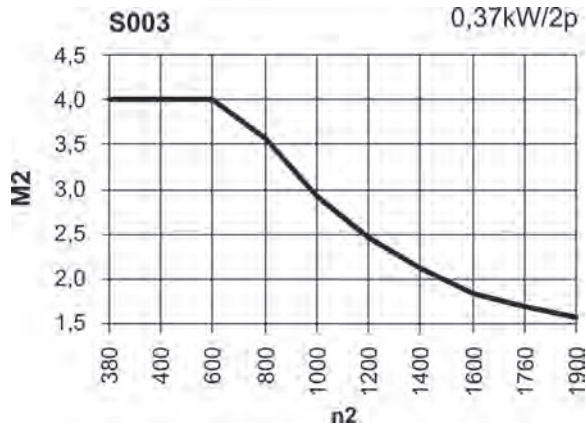



**S - Curve prestazioni / Performance curves / Courbes de performances /  
Leistungskurven / Curvas de prestaciones / 性能曲线**

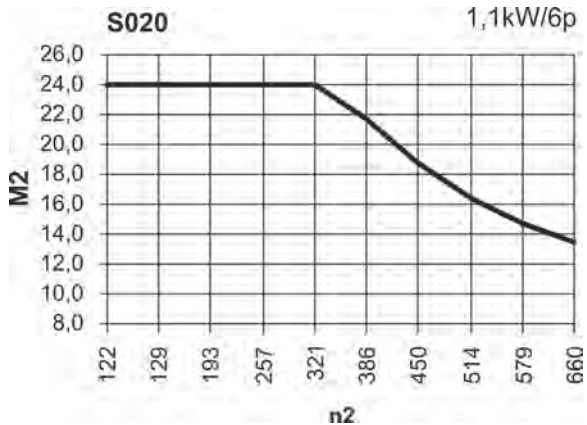
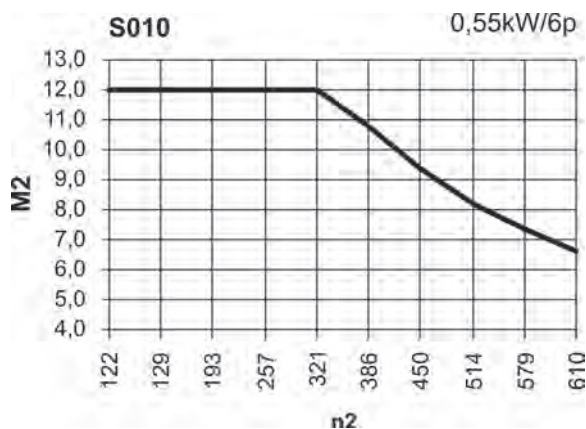
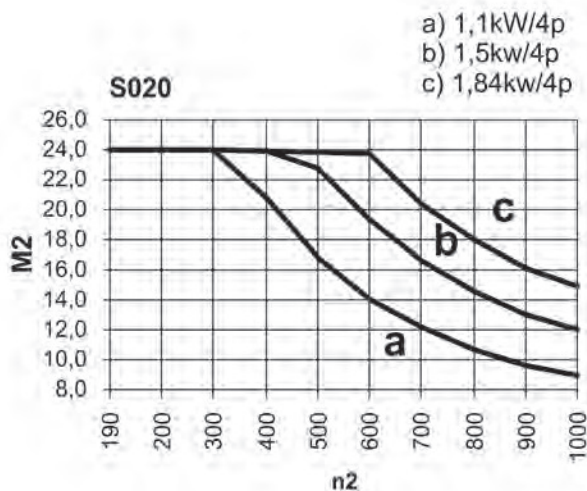
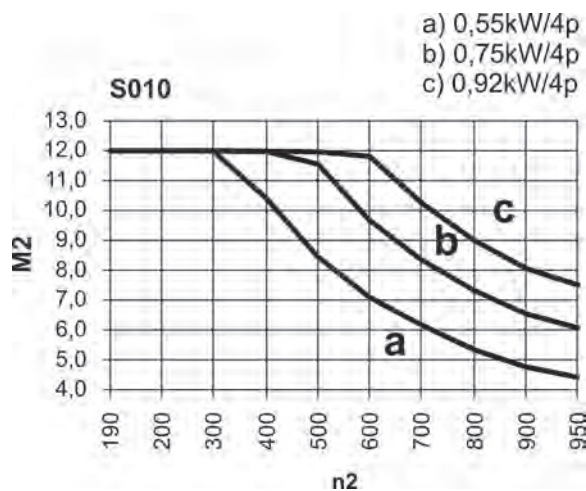
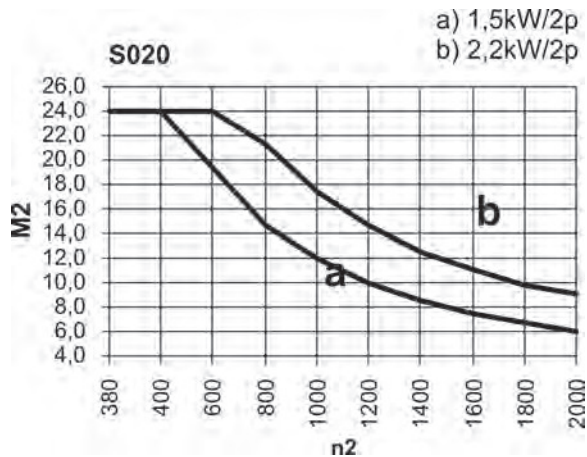
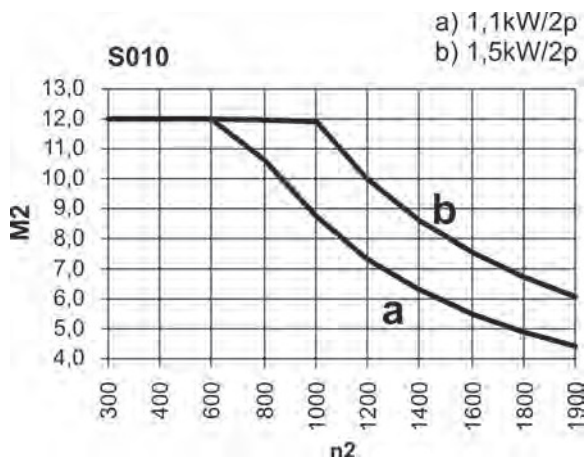

**S - Curve prestazioni / Performance curves / Courbes de performances / Leistungskurven / Curvas de prestaciones / 性能曲线**

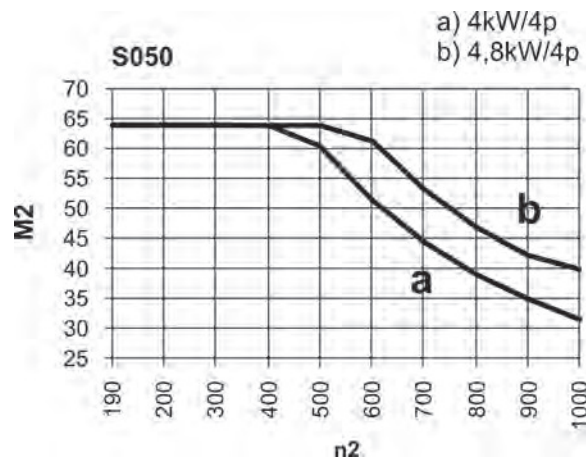
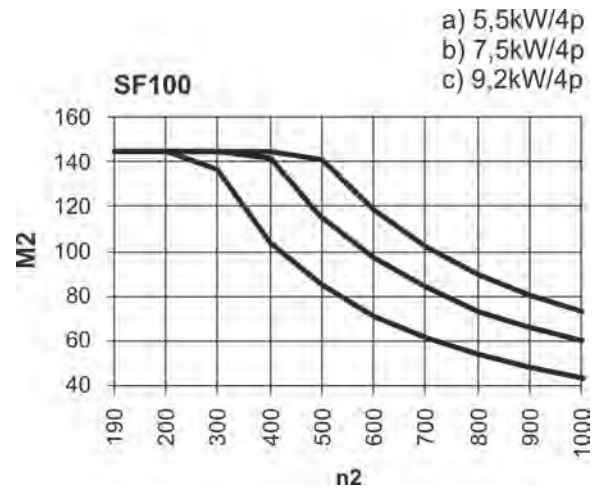
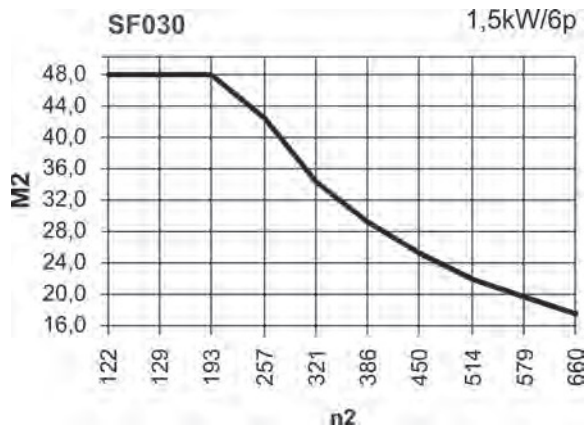
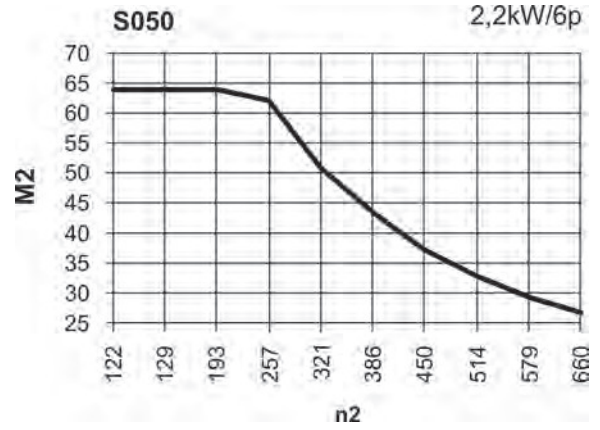
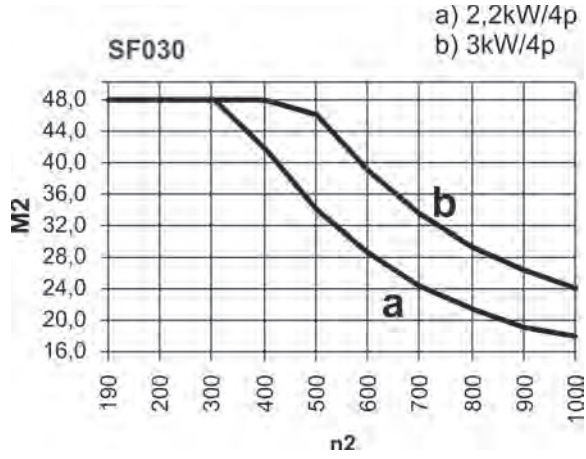

## S - Curve prestazioni / Performance curves / Courbes de performances / Leistungskurven / Curvas de prestaciones / 性能曲线

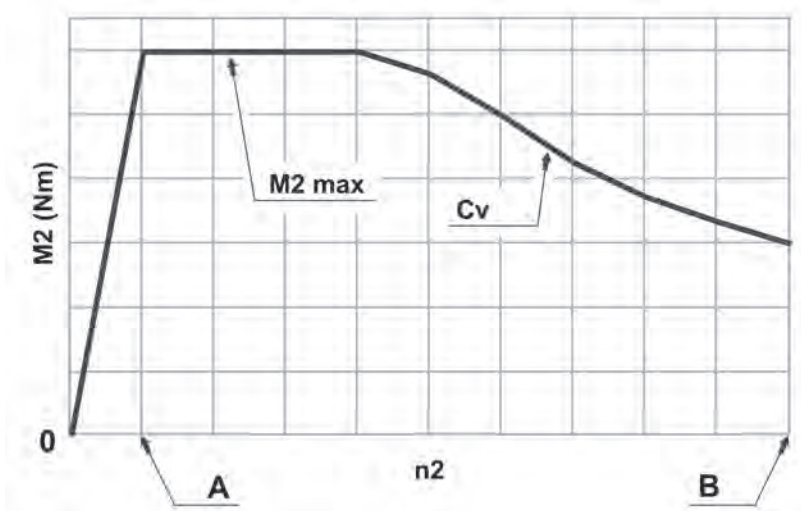

### Curva di coppia con differenziale

IT

La curva di coppia "Cv" del motovariatore con differenziale dal punto "n(b)" al punto "n(a)" corrisponde alla curva di coppia del corrispondente motovariatore senza differenziale.

In corrispondenza del punto "n(b)" la curva di coppia del motovariatore con differenziale scende sino a 0, in questa area la prestazione del gruppo può non essere regolare e presentare problematiche di slittamento. Occorre pertanto verificare con estrema attenzione la coppia richiesta dalla macchina.

### Torque curve with differential device

UK

"Cv" torque curve of the motovariator with differential device, from "n(b)" to "n(a)", corresponds to the same motovariator without differential device.

Close to point "n(b)", torque curve of motovariator with differential goes down to 0, in this area the performance could be irregular and cause slipping problems to satellite. Therefore it is necessary to accurately verify application torque.

### Courbe de couple avec différentiel

FR

La courbe de couple "Cv" du motovariateur avec différentiel du point n(b) jusqu'à le point n(a) correspond à la courbe de couple du même motovariateur sans différentiel.

Près du point A la courbe de couple du motovariateur avec différentiel baisse jusqu'à 0, dans cette zone la performance du groupe peut être irrégulière et présenter des problèmes de glissement. Donc il faut bien vérifier le couple demandé par l'application.

### Drehmomentkurve mit differentialgetriebe

DE

Drehmomentkurve (Cv) für Verstellgetriebe mit Differential. Von Punkt A nach Punkt B: Drehmomentkurve Verstellgetriebe ohne Differential.

Bei Drehzahl (n2) gegen 0 U./min., kann es zu Problemen mit der Getriebeleistung, sowie zu Unregelmäßigkeiten durch Schlupf kommen. Anwendung auf die geforderten Drehmomente hin überprüfen.

### Curva con diferencial

ES

La curva de par "cv" del motovariador con diferencial del punto "n(b)" al punto "n(a)" corresponde a la curva de par del motovariador sin diferencial.

Por debajo del punto "n(b)" la curva de par del motovariador con diferencia descende hacia 0, en esta área las prestaciones podrían ser irregulares y presentar problemas de deslizamiento. Es necesario por lo tanto verificar con atención el par solicitado por la maquinaria.

### 带有差速器的电机变速器的扭矩曲线

CN

带有差速器的电机变速器的"Cv"扭矩曲线，从 $i^n n(b)_{\pm}$ 到 $i^n n(a)_{\pm}$ ，对应于相同的不带有差速器的电机变速器。

接近 $i^n n$ 在该区域，性能是不规则的，可能产生向卫星滑动的问题。

因此，必须精确地查证应用扭矩。



**SF - Dimensioni / Dimensions / Encombremets /  
Abmessungen / Dimensiones / 尺寸**

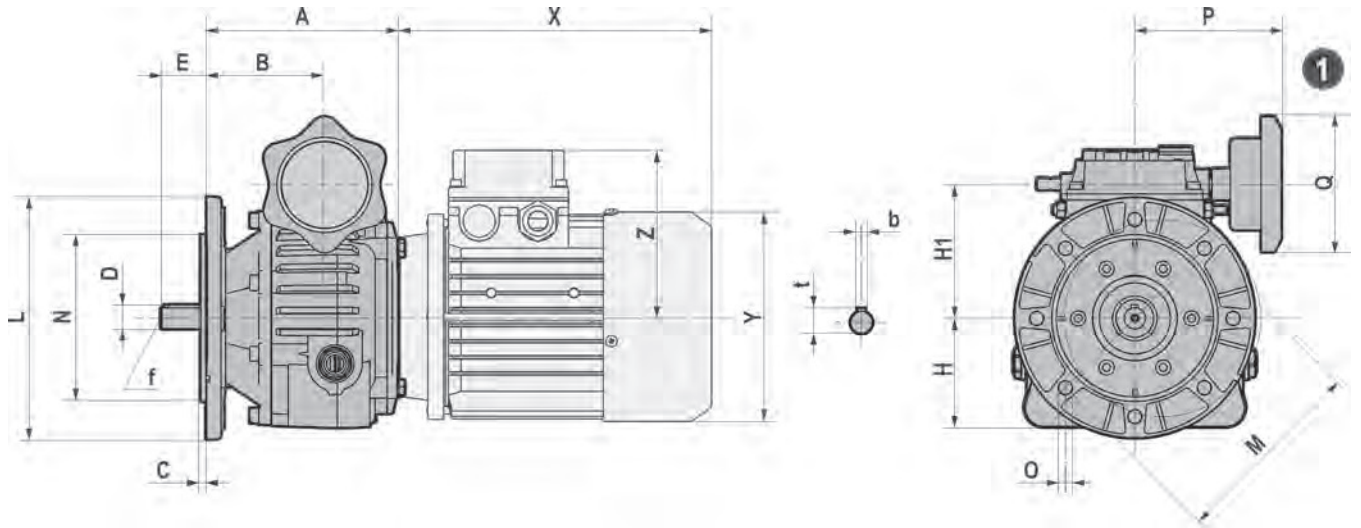

SF	A	B	C	D	E	H	H1	L	M	N
003	103	65.5	3	11 j6	23	58	75	140	115	95
			3.5	14 j6	30			160	130	110
005	127.5	78.5	3.5	14 j6	30	72.5	88	160	130	110
			3.5	19 j6	40			200	165	130
010	151	94.5	3.5	19 j6	40	90	107	160	130	110
			3.5	24 j6	50			200	165	130
020	173	105.5	3.5	24 j6	50	108	126	200	165	130
			4	28 j6	60			250	215	180
030/050	208	123.5	4	28 j6	60	134	158.5	250	215	180
			4	38 k6	80			300	265	230
100	266	164.5	4	38 k6	80	165	205.5	300	265	230
			5	42 k6	80			350	300	250

SF	O	P	Q	b	t	f	X	Y	Z	~Kg
003	9	97	90	4	12.5	M4	188	121	103.5	2.7
	9			5	16	M5				
005	9	97	90	5	16	M5	208.5	139	112	5.9
	11			6	21.5	M6				
010	9	107	90	6	21.5	M6	232.5	158	121.5	11.4
	11			8	27	M8				
020	11	117	90	8	27	M8	248	173	129.5	22.3
	14			8	31	M10				
030/050	14	154	120	8	31	M10	307.5	191	138.5	40.5
	14			10	41	M12				
100	14	184	120	10	41	M12	372.5	248.4	194	73
	18			12	45	M12				

## ST - Dimensioni / Dimensions / Encombresments / Abmessungen / Dimensiones / 尺寸

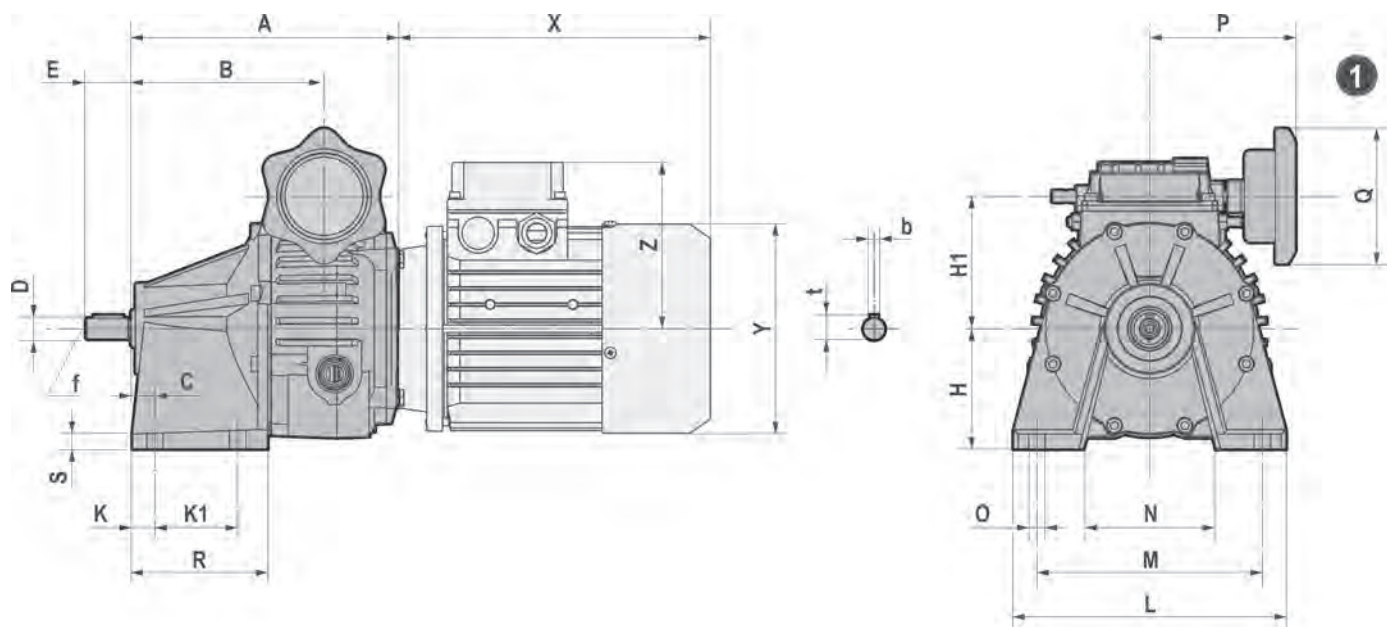

ST	A	B	C	D	E	H	H1	K	K1	L	M	N
003	131	93.5	16	11 j6	23	70	75	15	25	130	95	60
				14 j6	30							
005	177.5	128.5	16	14 j6	30	80	88	15	55	180	150	90
				19 j6	40							
010	213	156.5	19.5	19 j6	40	102	107	18.5	65	220	165	108
				24 j6	50							
020	251.5	184.5	25.5	24 j6	50	125	126	23.5	75	250	185	118
				28 j6	60							
030/050	294.5	210.5	27	38 k6	80	150	158.5	25	85	310	240	149
100	353.5	252.5	32	42 k6	80	190	205.5	29	120	384	295	193

ST	O	P	Q	R	S	b	t	f	X	Y	Z	~Kg
003	9	97	90	60	8	4	12.5	M4	188	121	103.5	3.0
						5	16	M6				
005	11	97	90	90	10	5	16	M6	208.5	139	112	8.7
						6	21.5	M6				
010	11	107	90	110	12	6	21.5	M6	232.5	158	121.5	16.1
						8	27	M8				
020	14	117	90	130	14	8	27	M8	248	173	129.5	27.3
						8	31	M8	273			
030/050	18	154	120	150	16	10	41	M10	307.5	191	138.5	41.5
									322.5			
100	20	184	120	186	20	12	45	M10	372.5	248.4	194	74.5
									410.5			



**SC - Dimensioni / Dimensions / Encombrements /  
Abmessungen / Dimensiones / 尺寸**

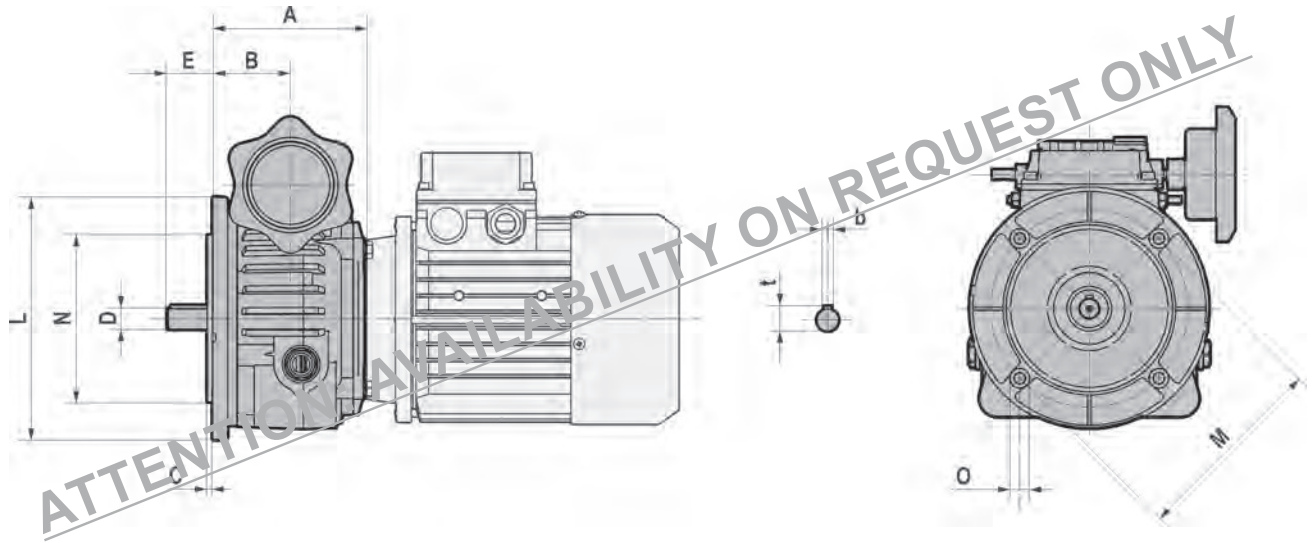

ATTENTION: AVAILABILITY ON REQUEST ONLY

SC	A	B	C	D	E	L	M	N	O	b	t
003	79	41.5	3	11 j6	23	140	115	95	M6	4	12.5
				14 j6	30					5	16
005	100.5	51.5	3.5	14 j6	30	160	130	110	M8	5	16
				19 j6	40					6	21.5
010	117	60.5	3.5	19 j6	40	200	165	130	M10	6	21.5
				24 j6	50					8	27
020	135.5	68.5	3.5	24 j6	50	200	165	130	M10	8	27
				28 j6	60					8	31

**SP - Dimensioni / Dimensions / Encombrements /  
Abmessungen / Dimensiones / 尺寸**

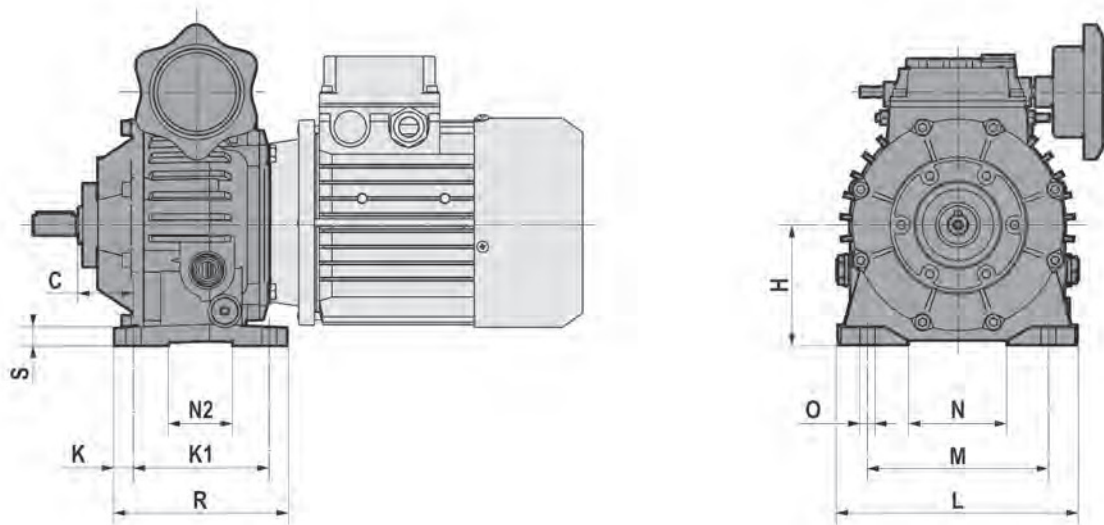

SP	C	H	K	K1	L	M	N	N2	O	R	S
005	36.5	80	12.5	90	155	120	42	65	10	115	12
010	42.5	102	12.5	110	200	150	86	75	11	135	13
020	55.5	125	12.5	115	235	205	103	90	11	140	16
030/050	25.5	150	15	220	290	255	118	140	14	250	20
100	55.5	180	25	255	365	320	140	175	18	305	25

**PAM - Dimensioni / Dimensions / Encombremets /  
Abmessungen / Dimensiones / 尺寸**

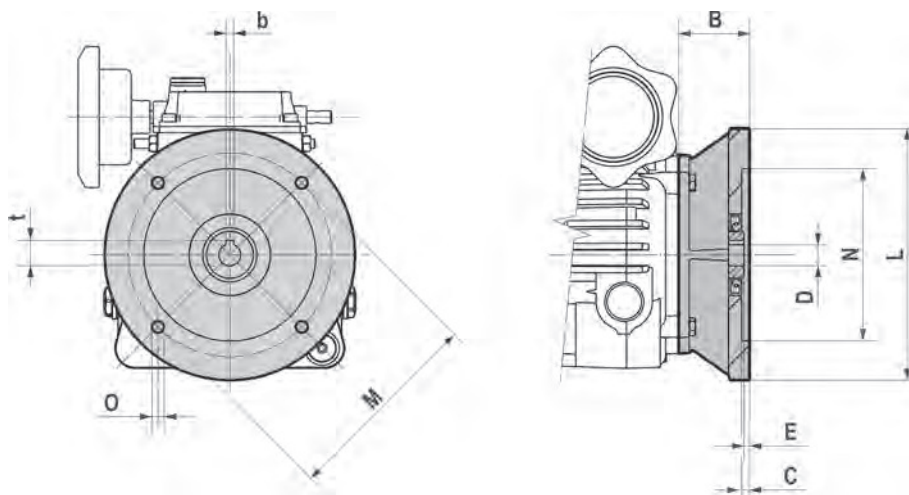

S	B	C	D	E	L	M	N	O	b	t
003	50	4	14	2	105	85	70	6.5	5	16.3
			11		140	115	95	M8	4	12.8
005	45	4	19	3	120	100	80	6.5	6	21.8
		4.5	14		160	130	110	M8	5	16.3
		4.5	19		200	165	130	M10	6	21.8
010	62	5	19	3.25	200	165	130	M10	6	21.8
			24						8	27.3
020	63	4.5	24	1.9	200	165	130	M10	8	27.3
	73	5	28		250	215	180	M12	8	31.3
030/050	72.5	5	28	2	250	215	180	M12	8	31.3
	87.5		38		300	265	230		10	41.3
100	95	5.5	38	5	300	265	230	13.5	10	41.3
	125	6	42	25	350	300	250	M16	12	45.3

**ECE - Dimensioni / Dimensions / Encombremets /  
Abmessungen / Dimensiones / 尺寸**

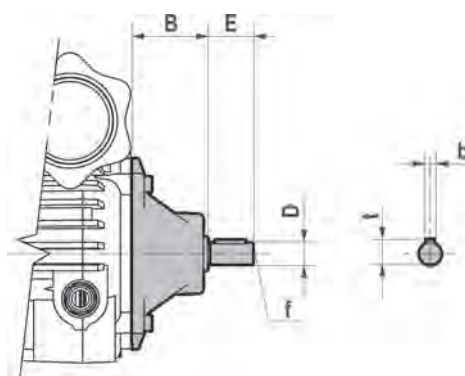

S	B	D	E	f	b	t
003	50	11	23	M4	4	12.5
005	50	14	30	M6	5	16
010	65	19	40	M6	6	21.5
020	70	24	50	M8	8	27
030/050	94.5	28	60	M8	8	31
100	110	38	80	M10	10	41

**SD - Dimensioni / Dimensions / Encombremets /  
Abmessungen / Dimensiones / 尺寸**

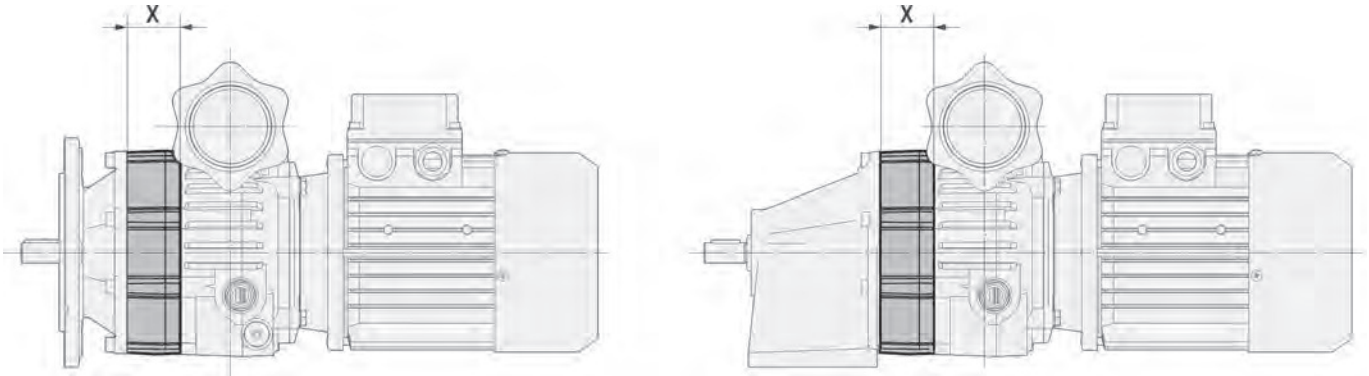

S	005	010	020	030/050	100
X	37.5	33.5	37	54	54

X - Quota di maggiorazione valida per tutte le versioni  
 X - Allowance value valid for all versions  
 X - Majoration de cote valide pour toutes les versions  
 X - Abmessungen sind für alle Versionen gültig  
 X - Cuota de incremento valida para todas las versiones  
 X - 公差值对所有版本都有效。

**PAM C - Dimensioni / Dimensions / Encombremets /  
Abmessungen / Dimensiones / 尺寸**

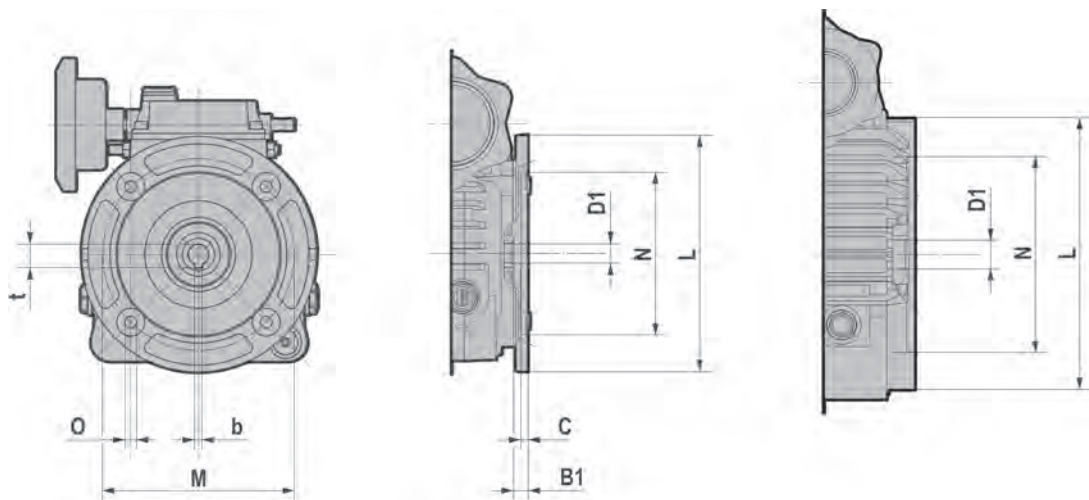

S	B1	C	D1	L	M	N	O	b	t
003	17.5	4	11	140	115	95	M8	4	12.8
005	10	4	14	160	130	110	M8	5	16.3
010	11	5	19	200	165	130	M10	6	21.8
020	/	/	24	200	165	130	M10	8	27.3
030/050	/	/	28	250	215	180	M12	8	31.3
100	/	/	38	300	265	230	M12	10	41.3

**Motori elettrici / Electric motors / Moteurs électriques /  
Elektromotoren / Motores electricos / 电机**

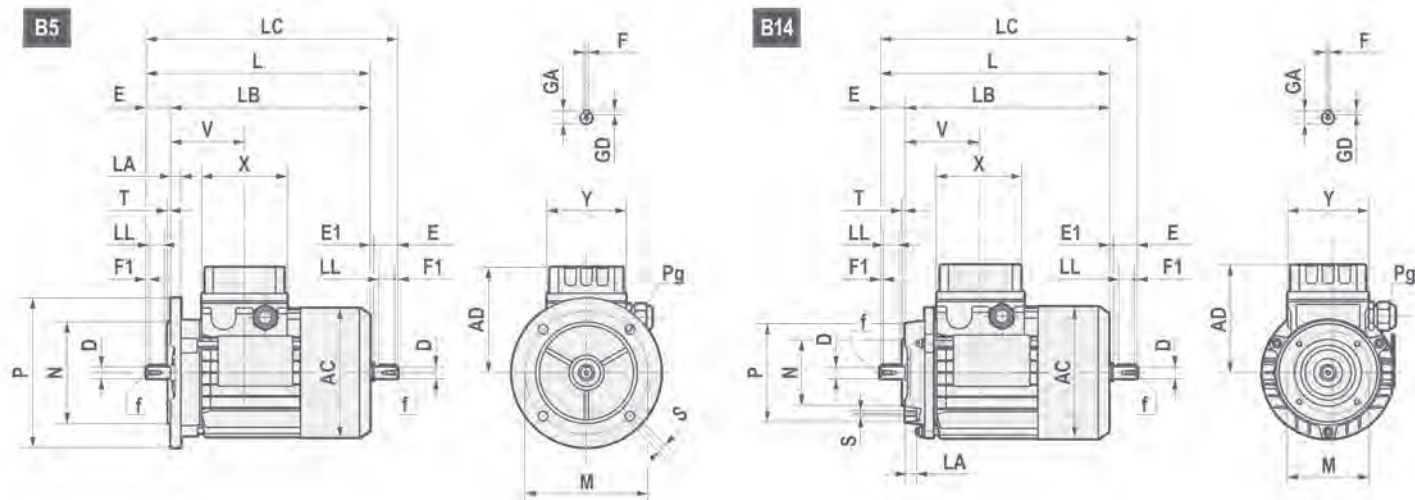

	AC	AD	L	LB	LC	X	Y	V	D	E	E1	f	F1	GA	F	GD	LL	Pg		
																		ø min	ø max	
<b>63</b>	121	103,5	211	188	235,5	80	74	69	11 j6	23	1,5	M4x10	2,5	12,5	4	4	15	M16x1,5	5	10
<b>71</b>	139	112,5	238,5	208,5	271	80	74	74,5	14 j6	30	2,5	M5x12,5	3	16	5	5	20	M20x1,5	6	12
<b>80</b>	158	121,5	272,5	232,5	314	80	74	78	19 j6	40	1,5	M6x16	5	21,5	6	6	30	M20x1,5	6	12
<b>90S</b>	173	129,5	298	248	349,5	98	98	89,5	24 j6	50	1,5	M8x19	5	27	8	7	35	M25x1,5	9	17
<b>90L</b>	173	129,5	323	273	374,5	98	98	89,5	24 j6	50	1,5	M8x19	5	27	8	7	35	M25x1,5	9	17
<b>100</b>	191	138,5	368	308	431,5	98	98	97,5	28 j6	60	2,5	M10x22	7,5	31	8	7	45	M25x1,5	9	17
<b>112</b>	210,5	153,5	382,5	323,5	447	98	98	100	28 j6	60	1,5	M10x22	7,5	31	8	7	45	M25x1,5	9	17
<b>132S</b>	248,4	177,5	452	372	536,5	118	118	115,5	38 k6	80	4	M12x28	10	41	10	8	60	M32x1,5	11	21
<b>132M/L</b>	248,4	177,5	490	410	574,5	118	118	115,5	38 k6	80	4	M12x28	10	41	10	8	60	M32x1,5	11	21

B5	M	N	P	LA	S	T
<b>63</b>	115	95 j6	140	9,5	9	3
<b>71</b>	130	110 j6	160	10	9,5	3,5
<b>80</b>	165	130 j6	200	12	11	3,5
<b>90</b>	165	130 j6	200	12	11	3,5
<b>100</b>	215	180 j6	250	15	14	4
<b>112</b>	215	180 j6	250	14,5	14	4
<b>132</b>	265	230 j6	300	20	14	3,5

B14	M	N	P	LA	S	T
<b>63</b>	75	60 j6	90	10,5	M5	2,5
<b>71</b>	85	70 j6	105	10,5	M6	2,5
<b>80</b>	100	80 j6	120	10,5	M6	3
<b>90</b>	115	95 j6	140	11,5	M8	3
<b>100</b>	130	110 j6	160	15	M8	3,5
<b>112</b>	130	110 j6	160	11,5	M8	3,5
<b>132</b>	165	130 j6	200	20,5	M10	3,5

**Potenza nominale (kW) / Nominal power (kW) / Puissance nominale (kW) /  
Nennleistung (kW) / Potencial nominal (kW) / 标称功率 (kW)**

	63A	63B	63C	71A	71B	71C	80A	80B	80C	90S
<b>2(*)</b>	0,18	0,25	0,37	0,37	0,55	0,75	0,75	1,1	1,5	1,5
<b>4(*)</b>	0,12	0,18	0,22	0,25	0,37	0,55	0,55	0,75	0,92	1,1
<b>6(*)</b>	0,09	0,12	0,15	0,18	0,25	0,37	0,37	0,55	0,75	0,75
<b>8(*)</b>			0,07	0,09	0,12	0,18	0,18	0,25	0,37	0,37
	90L	90LL	100LA	100LB	112M	112MS	132SA	132SB	132L	132M
<b>2(*)</b>	2,2		3	4	4	5,5	5,5	7,5	9,2	11
<b>4(*)</b>	1,5	1,84	2,2	3	4	4,8	5,5		7,5	9,2
<b>6(*)</b>	1,1		1,5	1,85	2,2	3	3		4	5,5
<b>8(*)</b>	0,55		0,75	1,1	1,5		2,2		3	

(\*) Poli / Poles / Pôles / Pole / Polos / 极性



Differenziale / Differential / Differentiel /  
Differential / Diferencial / 差速器

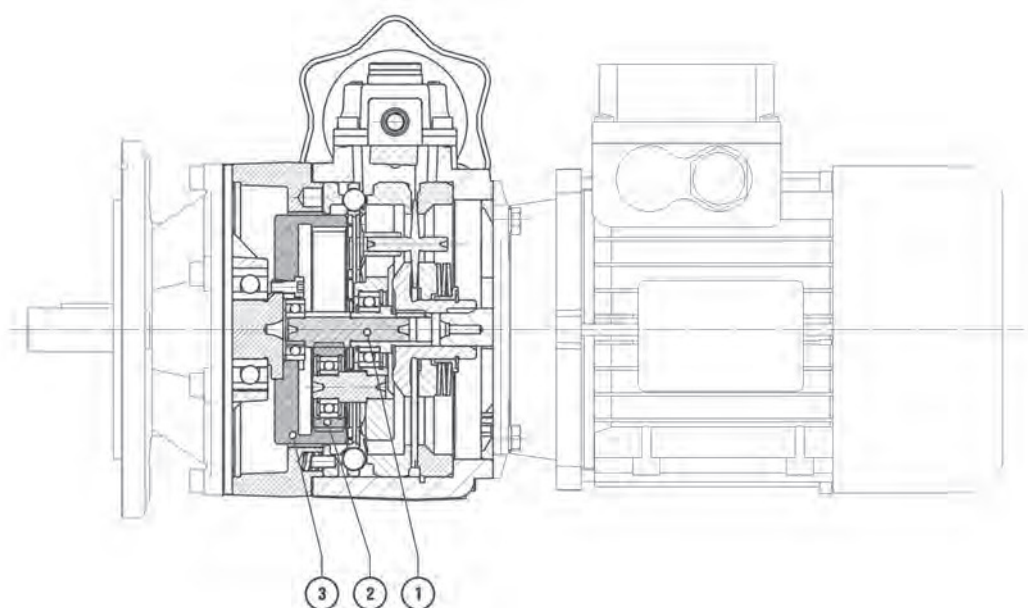

Differenziale

IT

Il motovariatore MOTOVARIO può essere fornito completo di gruppo epicicloidale/differenziale che consente una variazione della velocità in uscita da zero alla massima prevista.

Ciò è possibile in quanto la velocità costante in entrata al variatore viene trasmessa anche al pignone (1) di traino del riduttore epicicloidale. La velocità costante di entrata è trasformata in velocità variabile del variatore e ritrasmessa ai satelliti (2) del riduttore epicicloidale. In questo modo si eguaglia la velocità dei satelliti (2) a quella del pignone di traino (1); con tali condizioni la velocità della corona esterna è nulla e quindi il numero di giri sull'albero di uscita è zero.

Differential

UK

MOTOVARIO motovariators can be equipped with epicyclic differential units to vary output speed over the range between 0 RPM and maximum RPM. Zero RPM output speed is achieved by transmitting the constant speed of the input shaft not only to the variator's sun gears but also to the sun gear (1) which drives the additional epicyclic gear train. Input speed as varied by the variator is relayed to the planet gears (2) of the epicyclic differential. This causes planet gears (2) to rotate at the same speed as the driving sun gear (1). Under these conditions the annulus gear (3) of the epicyclic differential remains stationary, and there is no rotation of the output shaft.

Differentiel

FR

Le motovariateur MOTOVARIO peut être livré équipé d'un groupe épicycloïdal/différentiel qui permet une variation de la vitesse en sortie de zéro à la vitesse maximale prévue. Cela est possible du fait que la vitesse constante en entrée au variateur est également transmise au pignon (Rep.1) d'entraînement du réducteur épicycloïdal. La vitesse constante d'entrée est transformée en une vitesse variable du variateur puis retransmise aux satellites (Rep.2) du réducteur épicycloïdal. De cette façon, la vitesse des satellites (Rep.2) et la vitesse du pignon d'entraînement (Rep.1) sont égales; dans ces conditions, la vitesse de la couronne externe est nulle et, par conséquent, le nombre de tours sur l'arbre de sortie est égal à zéro.

Differential

DE

MOTOVARIO Verstellgetriebe lassen sich zusätzlich mit einem Planeten-Differential-Getriebe ausrüsten, wodurch eine Verstellung der Abtriebsdrehzahl von Null bis zum Höchstwert erzielt wird. Die konstante Antriebsdrehzahl der Verstellgetriebe-motoren wird auf das Sonnenrad (1) des Planetengetriebes übertragen. Die gleichförmige Antriebsdrehzahl wird somit in eine veränderliche umgewandelt und an die Planeten (2) des Differentials übertragen. Auf diese Weise werden die Drehzahlen von Planeten (2) und Sonnenrad (1) aufeinander abgestimmt. In diesem Fall bleibt das Außenrad in Ruhe und die Drehzahl der Abtriebswelle ist gleich Null.

Diferencial

ES

El variador de velocidad MOTOVARIO puede ser suministrado con el grupo epicicloidale/diferencial que permite obtener una variación de la velocidad de salida entre cero y aquella máxima prevista. Ello es posible en cuanto la velocidad constante en entrada al variador en transmitida también al pinón (1) de tracción del reductor epicicloidale. La velocidad constante de entrada es transformada en velocidad variable del variador y retransmitida a los satélites (2) del reductor epicicloidale. De este modo se iguala la velocidad de los satélites (2) a aquella del pinón de tracción (1); en estas condiciones la velocidad de la corona externa es cero, por lo que el número de revoluciones en el eje de salida es también cero.

差速器

CN

MOTOVARIO 减速器可以配备有周转差速装置，以在从0 RPM 到最大转速 RPM的整个速度范围改变输出速度。零速 RPM 输出可以通过恒定的输入轴速度不但传送给减速器的太阳滚道而且也传送给驱动另一个周转齿轮系的太阳齿轮 (1) 来获得。随减速器变化的输入速度被中继到周转差速器的行星齿轮 (2)。这可以导致行星齿轮 (2) 与驱动太阳轮 (1) 相同的速度旋转。在这些条件下，周转差速器的环形齿轮 (3) 仍然保持静止不动，输出轴也不旋转。



**Servocomando elettrico / Electrical servocontrol / Servocommande électrique / Elektrische Servosteuerung / Servocomando electrico / 电气狼心肠控制**

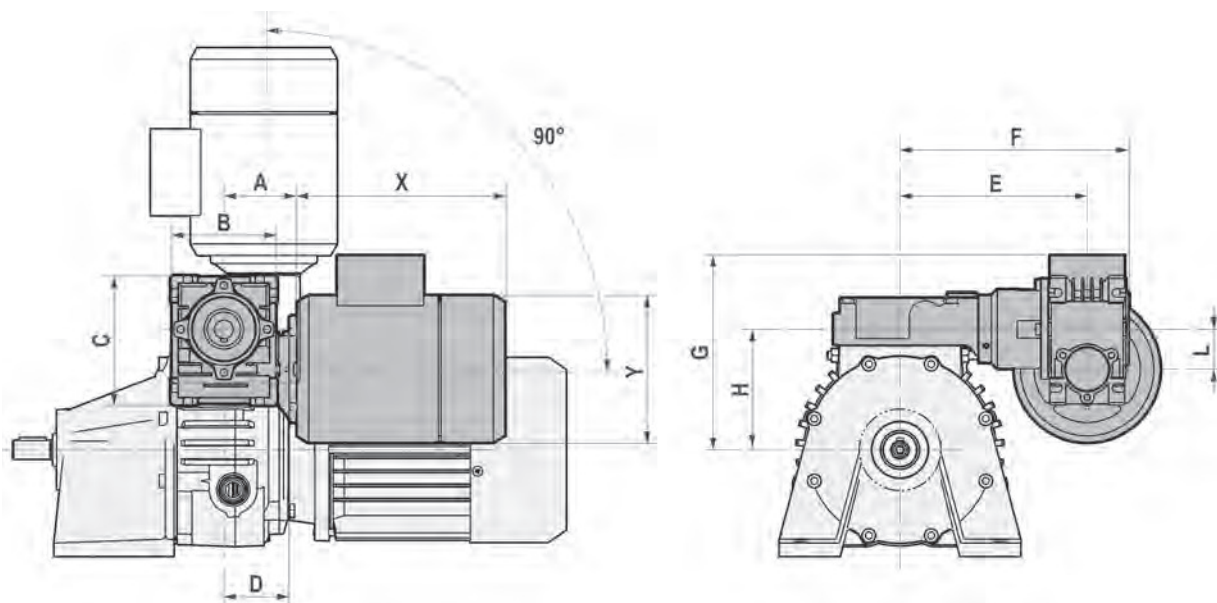

S	A	B	C	D	E	F	G	H	L	X	Y
<b>005</b>	55	80	97	49	140.5	172	130.5	90.5	30	169	110
<b>010</b>	55	80	97	56.5	150.5	182	148.5	108.5	30	169	110
<b>020</b>	55	80	97	67.5	160.5	192	167.5	127.5	30	169	110
<b>030/050</b>	55	80	97	84.5	164	195.5	198.5	158.5	30	169	110
<b>100</b>	55	80	97	102	204	235.5	245.5	205.5	30	188	121

**TXF002-005-010**  
**S005-010-020-030/050**  
 P1 = 0.09 kW/4 - i=30

**S100**  
 P1 = 0.18 kW/4 - i=30

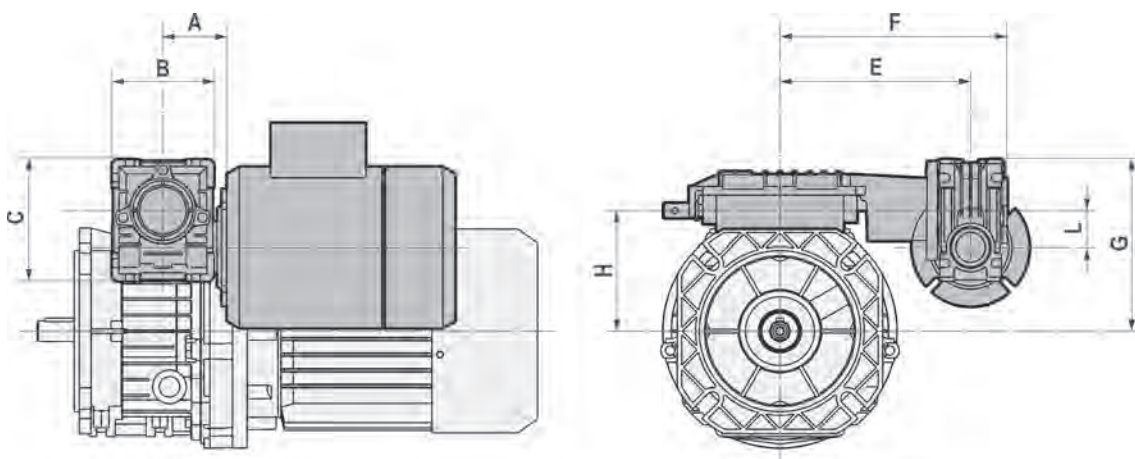

TXF	A	B	C	E	F	G	H	L
<b>002</b>	45	70	83	130	155	104	69	25
<b>005</b>	45	70	83	130	155	117	82	25
<b>010</b>	45	70	83	140	165	138	103	25

- Il motore pilota deve essere alimentato dal motore principale in quanto la regolazione dei giri deve avvenire a motore principale in moto.
- The servomotor must be linked to the main variator drive motor since the speed setting must only be varied while the motovariator is running.
- Le moteur pilote doit être alimenté à partir du moteur principal car la variation des tours doit se faire moteur principal en marche.
- Aufgrund der nur bei laufendem Motor freigegebenen Drehzahlverstellung ist der Steuermotor durch den Hauptmotor zu versorgen.
- El motor del servocomando debe ser alimentado por el motor principal dado que la regulación debe ser efectuada con el motor principal en movimiento.
- 伺服电机连接至主电机，因为设定速度只能在 电机变速器运行时才可以变化。

Servocomando elettrico / Electrical servocontrol / Servocommande électrique / Elektrische Servosteuerung / Servocomando electrico / 电气狼心肠控制

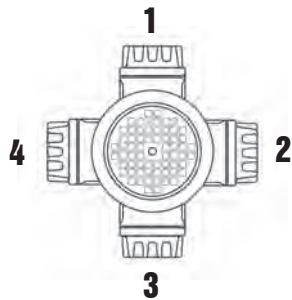

POS.1

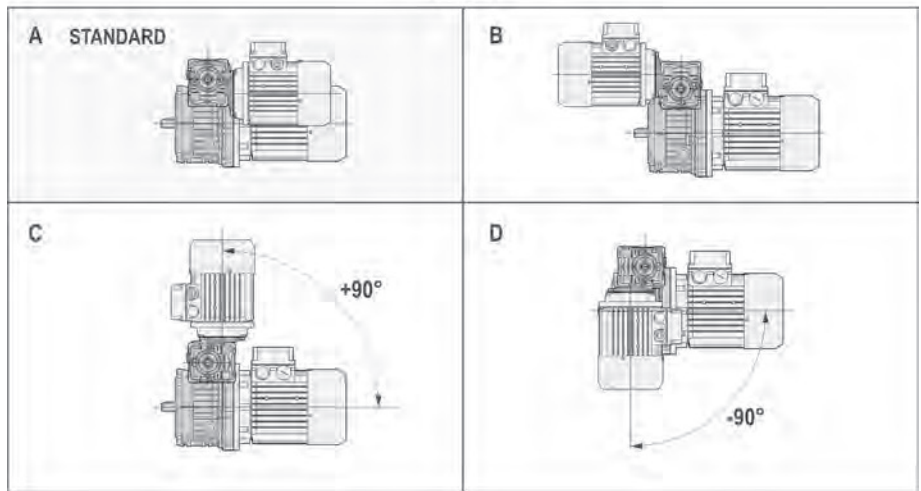

POS.2

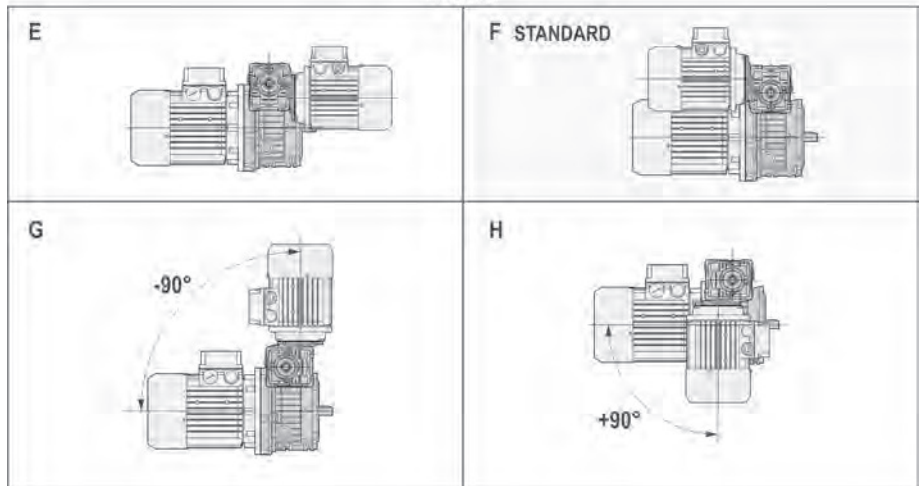

- Posizione morsetteria, se non diversamente specificato, il gruppo viene fornito con morsetteria in pos.1.
- Position of terminal box, unless otherwise specified, the gear reducer is supplied with terminal box in position 1.
- Position du bornier, sauf indications contraires, le réducteur est fourni avec boîte à borne en position 1.
- Klemmkastenlage, Sofern nichts Gegenteiliges angegeben, wird der Schneckengetriebemotor mit Klemmkastenlage 1 geliefert.
- Posición caja de bornes, si no está diferentemente especificado, el motorreductor se monta con la caja de bornes en posición 1.
- 接线盒位置, 除非另有规定, 齿轮变速器都配供有 1 号位接线盒。

TXF								
	A	B	C	D	E	F	G	H
TXF002-063								
TXF005-071								
TXF005-080								
TXF010-080								
TXF010-090								

SF-ST								
	A	B	C	D	E	F	G	H
S005-071								
S005-PAM120-160								
S005-PAM200								
S010-080/090								
S010-PAM200								
S020-090								
S020-PAM200-250								
S030/050-100-112								
S030/050-PAM250-300								
S100-132								
S100-PAM300-350								



- Piazzamento possibile
- Available position
- Position de montage disponible
- Mögliche Einbaulage
- Posición de montaje posible
- 不应许的安装位子



- Piazzamento non possibile
- Not available position
- Position de montage pas disponible
- Einbaulage nicht möglich
- Posición de montaje no posible
- 应许的安装位子

**Accessori**
**IT**

I seguenti accessori sono fornibili a richiesta (richiedere schede tecniche):

- Indicatore gravitazionale
- Rinvio angolare
- Finecorsa elettrico
- Sonda
- Tachimetro digitale
- Servocomando pneumatico.

**Accessories**
**UK**

Following accessories are available on request (ask for technical sheets):

- Gravitational indicator
- Adjustable right-angle control
- Electrical limit stop
- Transducer
- Tacho device digital
- Pneumatic speed control.

**Accessoires**
**FR**

Les accessoires suivants sont disponibles sur demande (demandez les feuilles techniques):

- Indicateur gravitationnel
- Commande orthogonale orientable
- Fin de course électrique
- Sonde de vitesse
- Tachymetre digitale
- Servocommande pneumatique.

**Zubehör**
**DE**

Folgende Zusätze sind auf Anfrage vorhanden (bitte Sie um technische Blätter):

- Indikator Schwerkraft
- Schwenkbare winkel Verstelleinrichtung
- Elektrische Verstellung mit Endschalter
- Impuls Aufnehmer
- Drehzahlanzeigergerät digital
- Pneumatische Servoverstelleinrichtung.

**Accesorios**
**ES**

Los siguientes accesorios están disponibles a petición (pedir hojas técnicas):

- Indicador gravitacional
- Mando ortogonal orientable
- Final de carrera eléctrico
- Sensor de proximidad
- Tacodinamo digital
- Servomando neumático.

**附件**
**CN**

可以配到如下配件 (技术材料请与我公司联系)

- 指标引力
- 可调式直角控制
- 电气限位
- 传感器2 / 3线
- 数字转速计
- 扭动速度控制